

LCD Display Module

QC12864B

User Manual

LCD12864 Specification

1. Features

- . Display construction - 128 * 64 Dots
- . Display mode - STN
- . Display color - Yellow Green / Blue
- . Viewing direction - 6 o' clock
- . Operating Power - VCC 5V
- . Type - COB (Chip On Board)
- . MCU I/F - 8-bit parallel or serial
- . Backlight - LED

2. Read/Write Timing

(a) Parallel Mode Timing

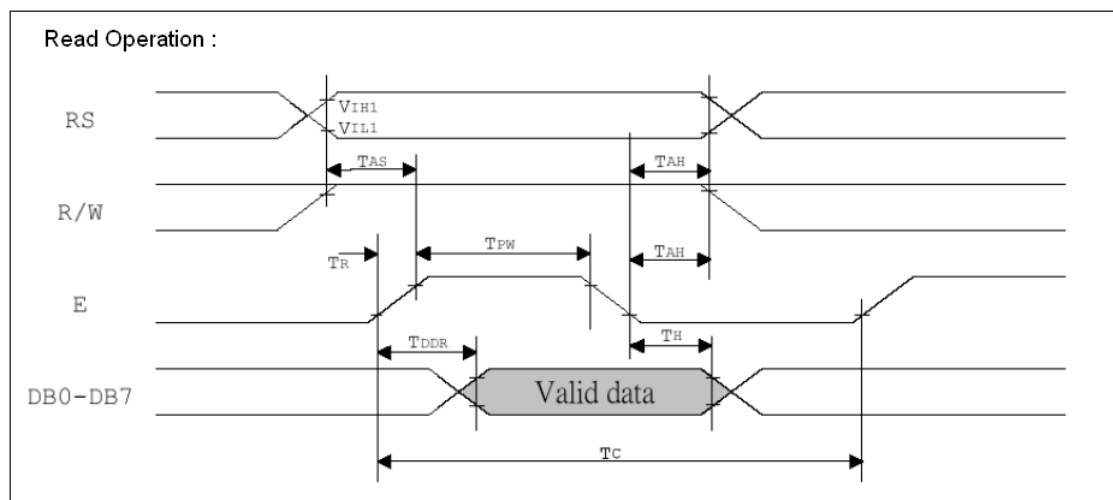
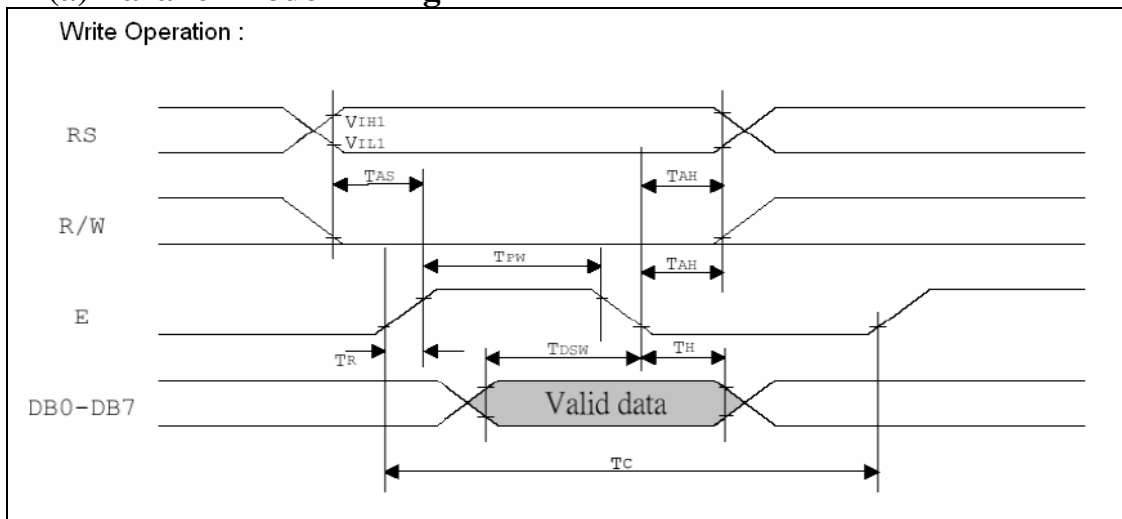

(b) Serial Mode Timing

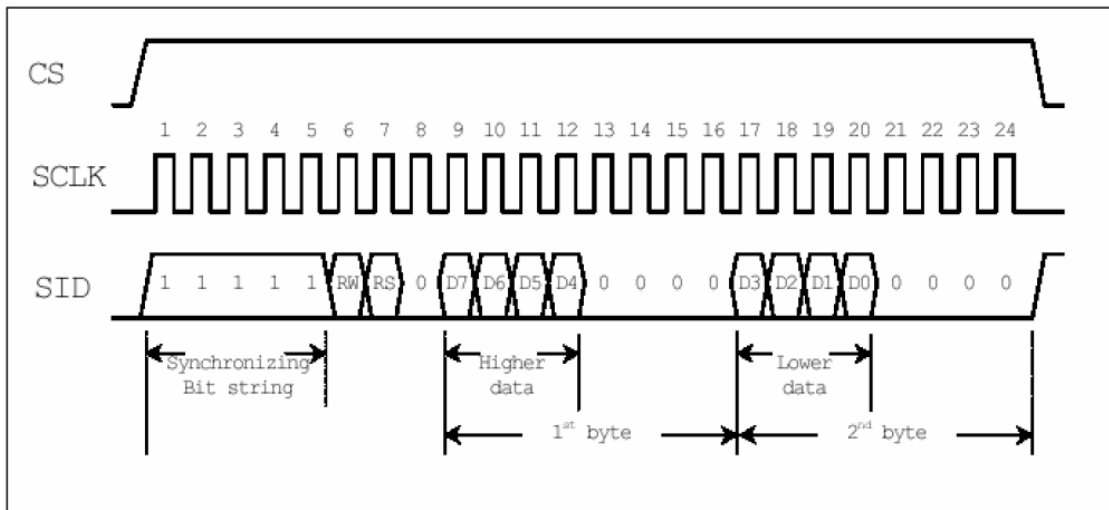

3. Electrical Characteristics

Symbol	Characteristics	Test Condition	Min.	Typ.	Max.	Unit
<i>Internal Clock Operation</i>						
f_{OSC}	OSC Frequency	R = 33K Ω	470	530	590	KHz
<i>External Clock Operation</i>						
f_{EX}	External Frequency	-	470	530	590	KHz
	Duty Cycle	-	45	50	55	%
T_R, T_F	Rise/Fall Time	-	-	-	0.2	μ s
TSCYC	Serial clock cycle	Pin E	400	-	-	ns
TSHW	SCLK high pulse width	Pin E	200	-	-	ns
TSLW	SCLK low pulse width	Pin E	200	-	-	ns
TSDS	SID data setup time	Pins RW	40	-	-	ns
TSDH	SID data hold time	Pins RW	40	-	-	ns
TCSS	CS setup time	Pins RS	60	-	-	ns
TCSH	CS hold time	Pins RS	60	-	-	ns

4. Block Diagram

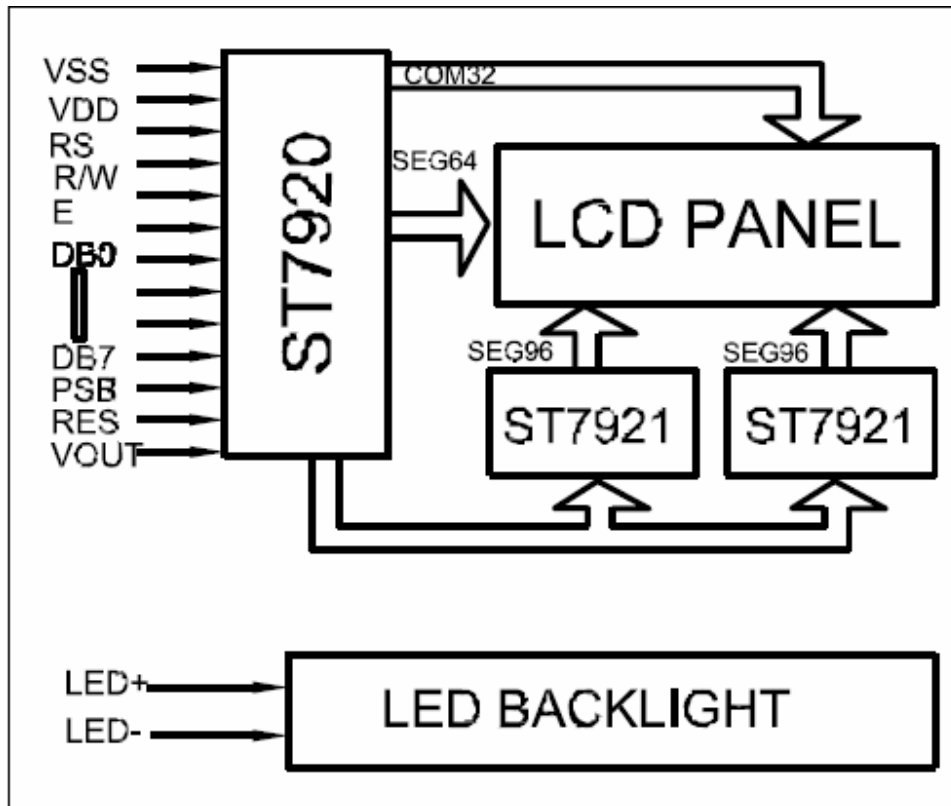

5. Instruction Set

Instruction set 1: (RE=0: basic instruction)

Ins	code										Description	Exec time (540KHZ)
	RS	RW	DB7	DB6	DB5	DB4	DB3	DB2	DB1	DB0		
CLEAR	0	0	0	0	0	0	0	0	0	1	Fill DDRAM with "20H", and set DDRAM address counter (AC) to "00H"	1.6 ms
HOME	0	0	0	0	0	0	0	0	1	X	Set DDRAM address counter (AC) to "00H", and put cursor to origin ; the content of DDRAM are not changed	72us
ENTRY MODE	0	0	0	0	0	0	0	1	I/D	S	Set cursor position and display shift when doing write or read operation	72us
DISPLAY ON/OFF	0	0	0	0	0	0	1	D	C	B	D=1: display ON C=1: cursor ON B=1: blink ON	72 us
CURSOR DISPLAY CONTROL	0	0	0	0	0	1	S/C	R/L	X	X	Cursor position and display shift control ; the content of DDRAM are not changed	72 us
FUNCTION SET	0	0	0	0	1	DL	X	0 RE	X	X	DL=1 8-BIT interface DL=0 4-BIT interface <u>RE=1: extended instruction</u> <u>RE=0: basic instruction</u>	72 us

SET CGRAM ADDR.	0	0	0	1	AC5	AC4	AC3	AC2	AC1	AC0	Set CGRAM address to address counter (AC) <u>Make sure that in extended instruction SR=0 (scroll or RAM address select)</u>	72 us
SET DDRAM ADDR.	0	0	1	0 AC6	AC5	AC4	AC3	AC2	AC1	AC0	Set DDRAM address to address counter (AC) AC6 is fixed to 0	72 us
READ BUSY FLAG (BF) & ADDR.	0	1	BF	AC6	AC5	AC4	AC3	AC2	AC1	AC0	Read busy flag (BF) for completion of internal operation, also Read out the value of address counter (AC)	0 us
WRITE RAM	1	0	D7	D6	D5	D4	D3	D2	D1	D0	Write data to internal RAM (DDRAM/CGRAM/IRAM/GDRAM)	72 us
READ RAM	1	1	D7	D6	D5	D4	D3	D2	D1	D0	Read data from internal RAM (DDRAM/CGRAM/IRAM/GDRAM)	72 us

Instruction set 2: (RE=1: extended instruction)

Inst.	code											description	Exec. time (540KHZ)
	RS	RW	DB7	DB6	DB5	DB4	DB3	DB2	DB1	DB0			
STAND BY	0	0	0	0	0	0	0	0	0	0	1	Enter stand by mode, any other instruction can terminate (Com1..32 halted, only Com33 ICON can display)	72 us
SCROLL or RAM ADDR. SELECT	0	0	0	0	0	0	0	0	0	1	SR	SR=1: enable vertical scroll position SR=0: enable IRAM address (<u>extended instruction</u>) SR=0: enable CGRAM address(<u>basic instruction</u>)	72 us
REVERSE	0	0	0	0	0	0	0	0	1	R1	R0	Select 1 out of 4 line (in DDRAM) and decide whether to reverse the display by toggling this instruction R1,R0 initial value is 00	72 us
EXTENDED FUNCTION SET	0	0	0	0	1	DL	X	1	RE	G	0	DL=1 8-BIT interface DL=0 4-BIT interface <u>RE=1: extended instruction set</u> <u>RE=0: basic instruction set</u> G=1 :graphic display ON G=0 :graphic display OFF	72 us
SET IRAM or SCROLL ADDR.	0	0	0	1	AC5	AC4	AC3	AC2	AC1	AC0		SR=1: AC5-AC0 the address of vertical scroll SR=0: AC3-AC0 the address of ICON RAM	72 us
SET GRAPHIC RAM ADDR.	0	0	1	0 AC6	0 AC5	0 AC4	AC3	AC2	AC1	AC0		Set GDRAM address to address counter (AC) First set vertical address and the horizontal address by consecutive writing Vertical address range AC6...AC0 Horizontal address range AC3...AC0	72 us

Note :

1. Make sure that ST7920 is not in busy state by reading the busy flag before sending instruction or data. If use delay loop instead please make sure the delay time is enough. Please refer to the instruction execution time.
2. "RE" is the selection bit of basic and extended instruction set. Each time when altering the value of RE it will remain. There is no need to set RE every time when using the same group of instruction set.

6. Coordinate

6.1 Graphic display coordinate

- Horizontal X : unit is bytes.
- Vertical Y : unit is bit.

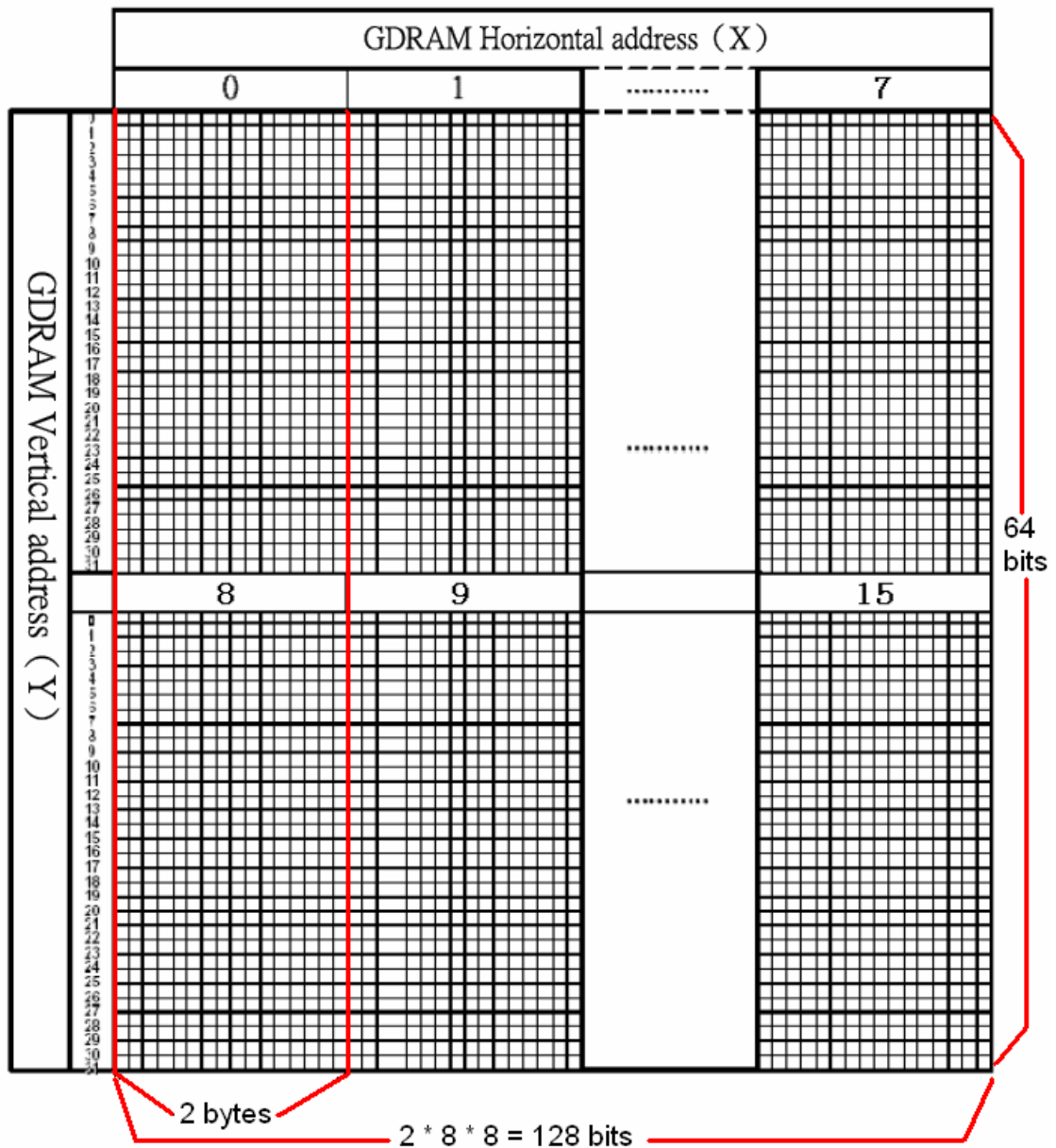

6.2 Character Display Coordinate

	X Address							
Line1	80H	81H	82H	83H	84H	85H	86H	87H
Line2	90H	91H	92H	93H	94H	95H	96H	97H
Line3	88H	89H	8AH	8BH	8CH	8DH	8EH	8FH
Line4	98H	99H	9AH	9BH	9CH	9DH	9EH	9FH

6.3 Character Map

- Address : 00 – 7F

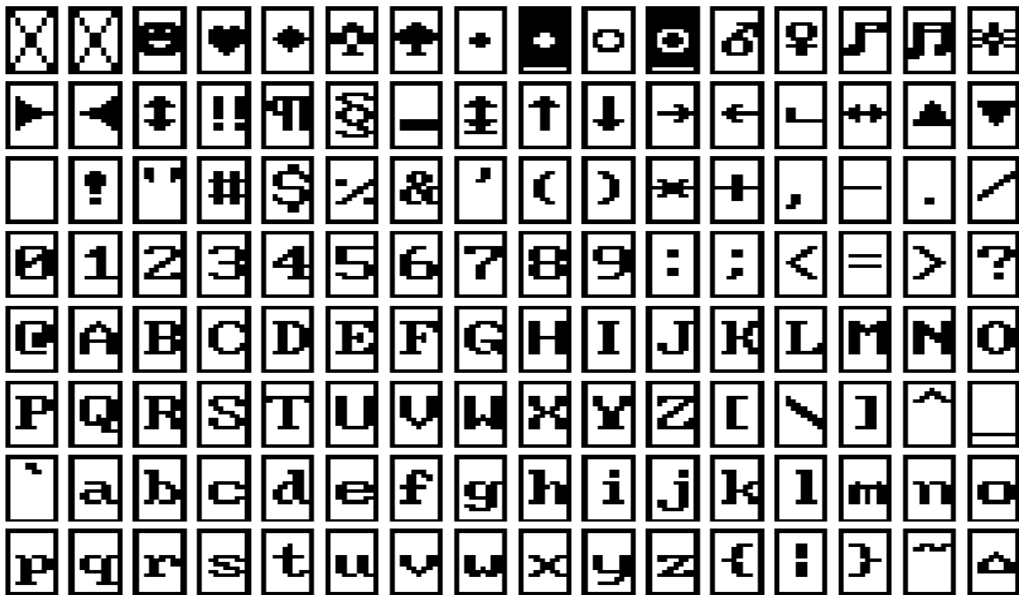

7. Access Graphic RAM (GDRAM)

GDRAM address is set by writing 2 consecutive bytes for vertical address and horizontal address. Two-bytes data write to GDRAM for one address. Address counter will automatically increase by one for the next two-byte data. The procedure is as followings.

1. Set vertical address (Y) for GDRAM
2. Set horizontal address (X) for GDRAM
3. Write D15~D8 to GDRAM 中(first byte)
4. Write D7~D0 to GDRAM 中(second byte)

8. Dimension

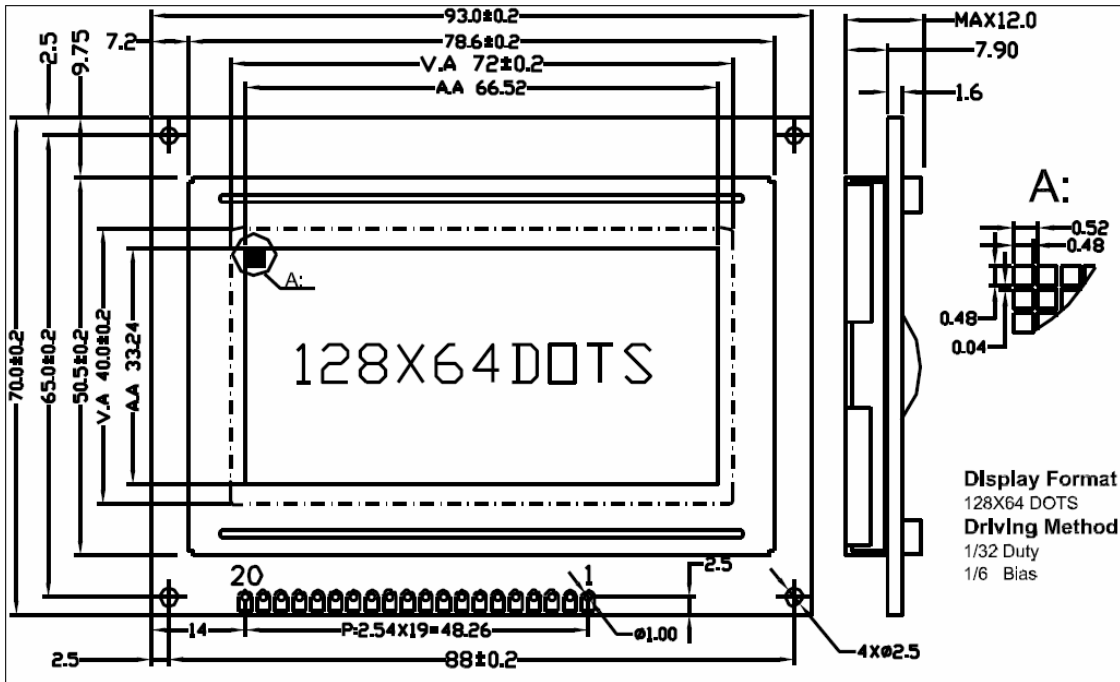

9. Interface

PIN NO.	SYMBOL	DESCRIPTION	FUNCTION
1	VSS	GROUND	0V (GND)
2	VDD	POWER SUPPLY FOR LOGIC CIRCUIT	+5V
3	V0/VDD/NC	LCD CONTRAST ADJUSTMENT OR LCD VOLTAGE OR NC	
4	D/I	INSTRUCTION/DATA REGISTER SELECTION	D/I = 0 : INSTRUCTION REGISTER D/I = 1 : DATA REGISTER
5	R/W	READ/WRITE SELECTION	R/W = 0 : REGISTER WRITE R/W = 1 : REGISTER READ
6	E	ENABLE SIGNAL	
7	DB0	DATA INPUT/OUTPUT LINES	8 BIT: DB0-DB7
8	DB1		
9	DB2		
10	DB3		
11	DB4		
12	DB5		
13	DB6		
14	DB7		
15	PSB	SERIAL/PARALLEL SELECTION	PSB=0:SERIAL MODE PSB=1:8/4BIT PARALLEL BUS MODE
16	NC		
17	RST	RESET SIGNAL	RSTB=0,DISPLAY OFF,DISPLAY FROM LINE 0.
18	VEE/NC	LCD DRIVE VOLTAGE/NC	
19	A	SUPPLY VOLTAGE FOR LED+	+5V
20	K	SUPPLY VOLTAGE FOR LED-	0V