

**XENSIV™ magnetic position sensors**

**Features**

- Two discrete linearized TMR bridges
- Differential sine and cosine output
- Ratiometric output signals
- High precision length measurement with multipole stripe magnet
- Wide temperature range from -40°C to 125°C
- Extreme small 6-ball wafer level package, 1.27 \* 0.93 \* 0.4mm (see [Chapter 8](#))

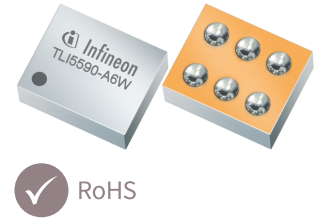

**Potential applications**

- Linear and angular incremental position sensing in industrial and consumer applications with highest accuracy requirements
- Lens positioning for zoom and focus adjusting in cameras

**Product validation**

Qualified for industrial applications according to JEDEC JESD47K.

**Description**

The TLI5590 is a two channel ratiometric gradiometer for high precise length measurement.

**Table 1**

Product Name	Marking	Ordering Code	Package
TLI5590-A6W	90A0	SP005631773	SG-WFWLB-6-3

## Table of contents

	<b>Table of contents</b> .....	2
<b>1</b>	<b>Block diagram</b> .....	3
<b>2</b>	<b>Pin configuration</b> .....	4
<b>3</b>	<b>Sensitive area</b> .....	5
<b>4</b>	<b>Application circuit</b> .....	6
<b>5</b>	<b>General product characteristics</b> .....	7
5.1	Absolute maximum ratings .....	7
5.2	Functional range .....	7
<b>6</b>	<b>Product features</b> .....	9
6.1	Functional description .....	9
6.2	Electrical characteristics .....	10
6.3	Residual measurement errors .....	11
6.3.1	Typical performance .....	11
<b>7</b>	<b>Application information</b> .....	12
7.1	Magnet .....	12
<b>8</b>	<b>Package</b> .....	13
8.1	Package information .....	13
8.2	Packing .....	14
8.3	Additional package information .....	14
<b>9</b>	<b>Revision history</b> .....	15
	<b>Disclaimer</b> .....	16

## 1 Block diagram

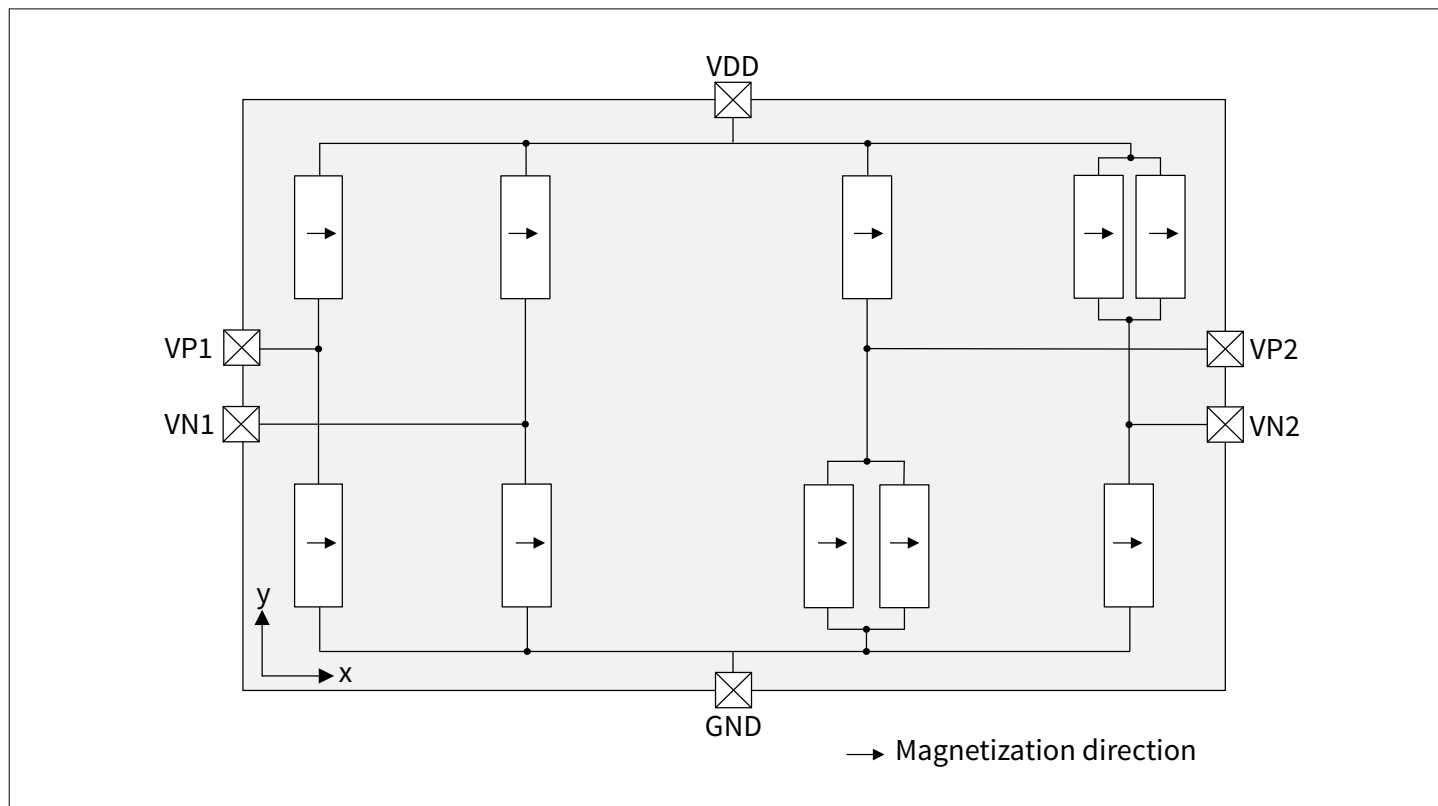

**Figure 1** Block diagram

The TLI5590 consists of two TMR -Wheatstone bridges. The TMR resistance depends on the direction and strength of the external magnetic field. In combination with a multipole magnet each bridge provides a differential output signal, i.e. sine and cosine signals. These signals can further be processed for relative position measurement.

## 2 Pin configuration

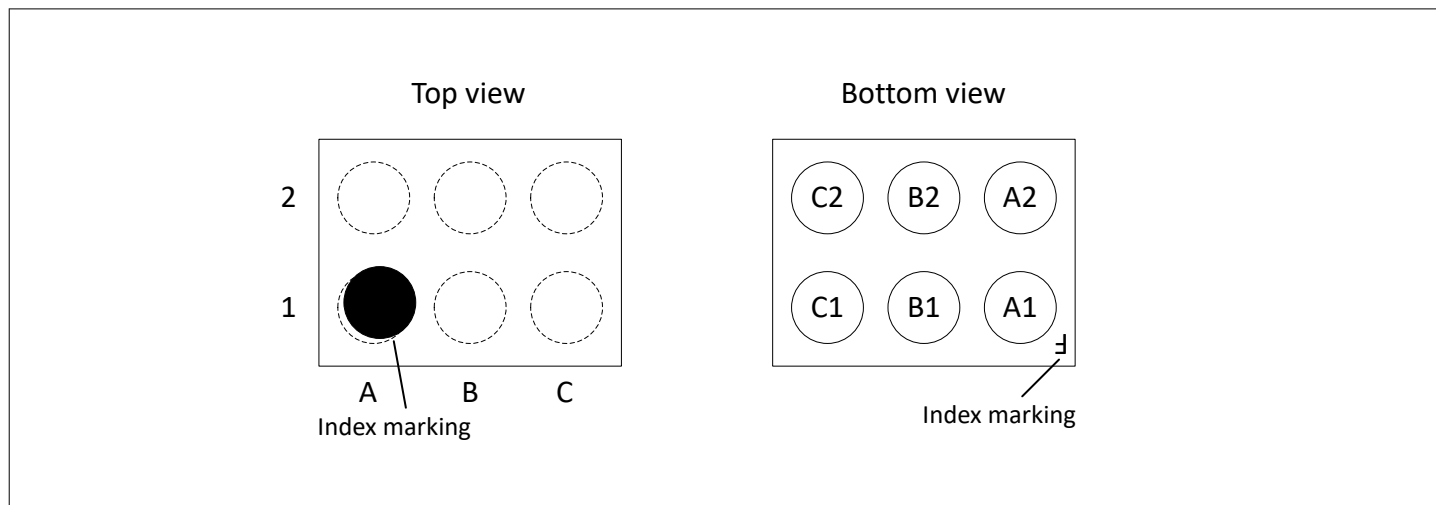
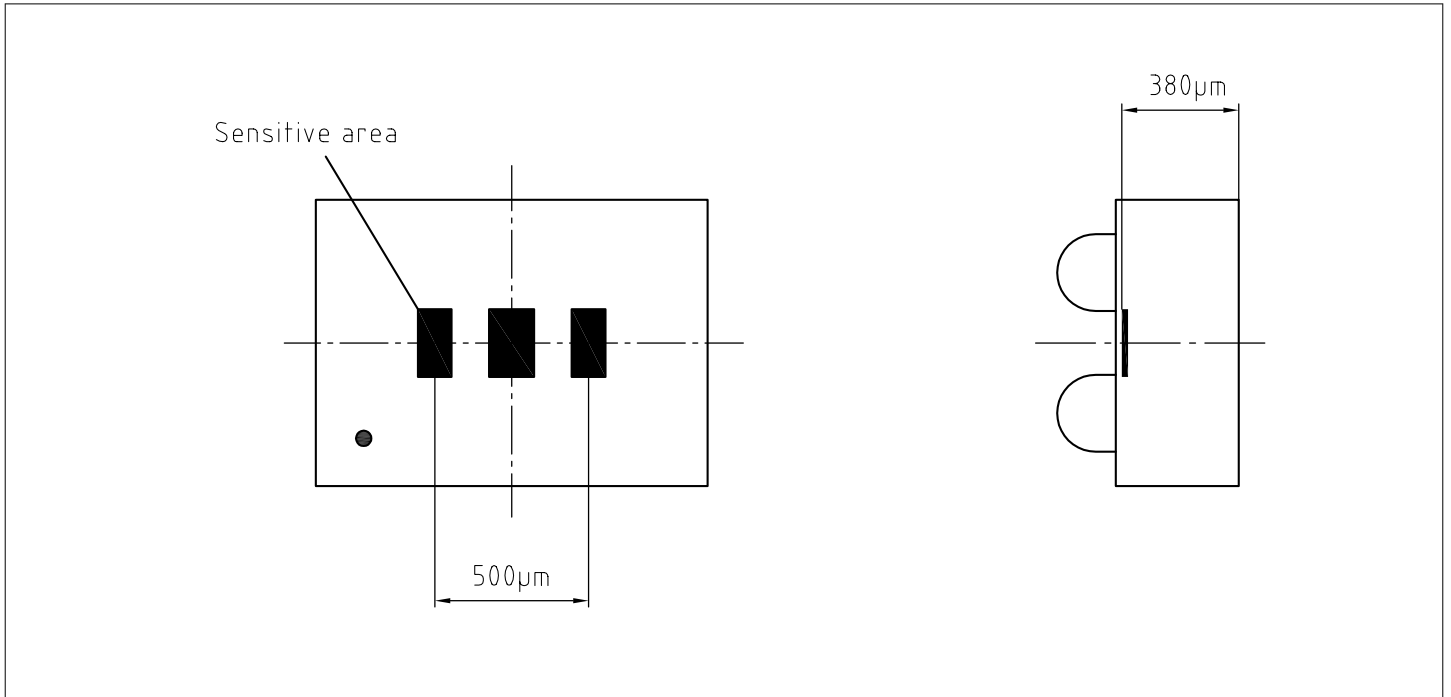

**Figure 2** TLI5590 - A6W pinout

**Table 2** SG-WFWLB-6-3 pin description and configuraiton

Pin no.	Name	Description
A1	VP2	Positive out of bridge #2
A2	VN2	Negative out of bridge #2
B1	GND	Ground
B2	VDD	Supply voltage
C1	VP1	Positive out of bridge #1
C2	VN1	Negative out of bridge #1

### 3 Sensitive area



**Figure 3** Placement of sensitive area in the package

## 4 Application circuit

Figure 4 shows the application circuit which is proposed for TLI5590. The value for the buffer capacitor  $C_b$  has to be adjusted according to the speed of the magnetic input signal. In combination with the TMR resistor it represents a low-pass-filter. This filter limits the bandwidth of the circuit but also improves the noise performance. Without any buffer capacitor  $C_b$ , the bandwidth of the device is determined by the TMR resistor and the input capacitor of the used ADC. This has to be considered and the ADC sample and hold time adjusted accordingly.

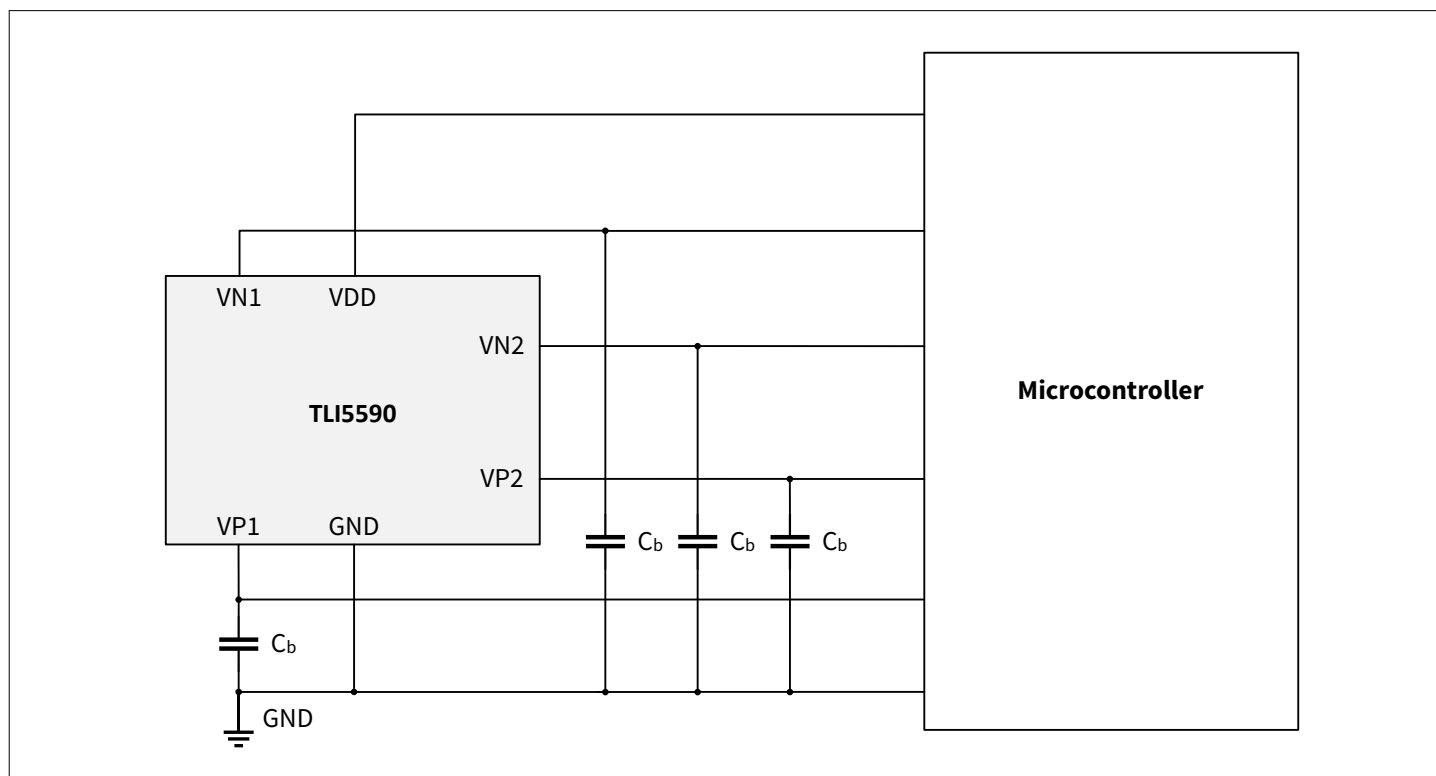

**Figure 4** Application circuit

## 5 General product characteristics

### 5.1 Absolute maximum ratings

All specifications are valid over the full temperature range and over lifetime.

Stresses above the maximum values listed here may cause permanent damage to the device. Exposure to absolute maximum rating conditions for extended periods may affect device reliability. Maximum ratings are absolute ratings; exceeding only one of these values may cause irreversible damage to the device.

**Table 3 Absolute maximum ratings**

Parameter	Symbol	Values			Unit	Note or condition
		Min.	Typ.	Max.		
Supply voltage	$V_{DD}$	-3.6	-	6.5	V	limited to 40 h over lifetime
Maximum ambient temperature	$T_{A\max}$	-40	-	125	°C	Temperature cycle 850x -40°C to 125°C acc. JEDEC JESD47K
Storage temperature	$T_{\text{storage}}$	-40	-	150	°C	1000h HTSL at 150°C acc. JEDEC JESD47K
Magnetic field	$B_{\max}$	-350	-	350	mT	max. 5 min. at 125°C

**Table 4 ESD voltage**

Parameter	Symbol	Values			Unit	Note or condition
		Min.	Typ.	Max.		
ESD HBM	$V_{HBM}$	-2	-	2	kV	HBM contact discharge for all pins, according to ANSI/ESDA/JEDEC JS-001-2010

### 5.2 Functional range

**Table 5 Functional range**

Parameter	Symbol	Values			Unit	Note or condition
		Min.	Typ.	Max.		
Supply voltage	$V_{DD}$	1	3.3	5.5	V	
Supply current	$I_{CC}$	-	1	-	mA	This corresponds to a typical voltage of $V_{Br}=3.3V$ and a resistance of $R_{Br}=6.6k\Omega$
Operating ambient temperature	$T_A$	-40	-	125	°C	1000h HTOL at 125°C, temperature budget acc. JEDEC JESD47K

**Table 6**                    **Magnetic parameters**

Parameter	Symbol	Values			Unit	Note or condition
		Min.	Typ.	Max.		
Magnetic field range	$B$	-5	-	5	mT	
Bandwidth	$f_{BW}$	-	5	-	kHz	Assumption: 6.6kOhm TMR resistance and max. 5nF capacitance $C_{out}$ , $f_{characteristic}=4.8kHz$



## 6 Product features

### 6.1 Functional description

The measurement principle of the sensor is based on the TMR (tunneling magneto-resistance) effect. The sensor measures the strength of the magnetic field parallel to the package surface. The sensor provides two differential analog output signals for external calculation. The provided output signal is ratiometric to the supply voltage.

A magnetic flux  $B$  parallel to the package plane influences the TMR cells of the sensor. The strength of the flux controls the resistance of the sensor.

For correct operation the pole length  $l_{pole}$  of the magnet needs to fit the TMR bridge distance. Please see [Table 9](#) for details.

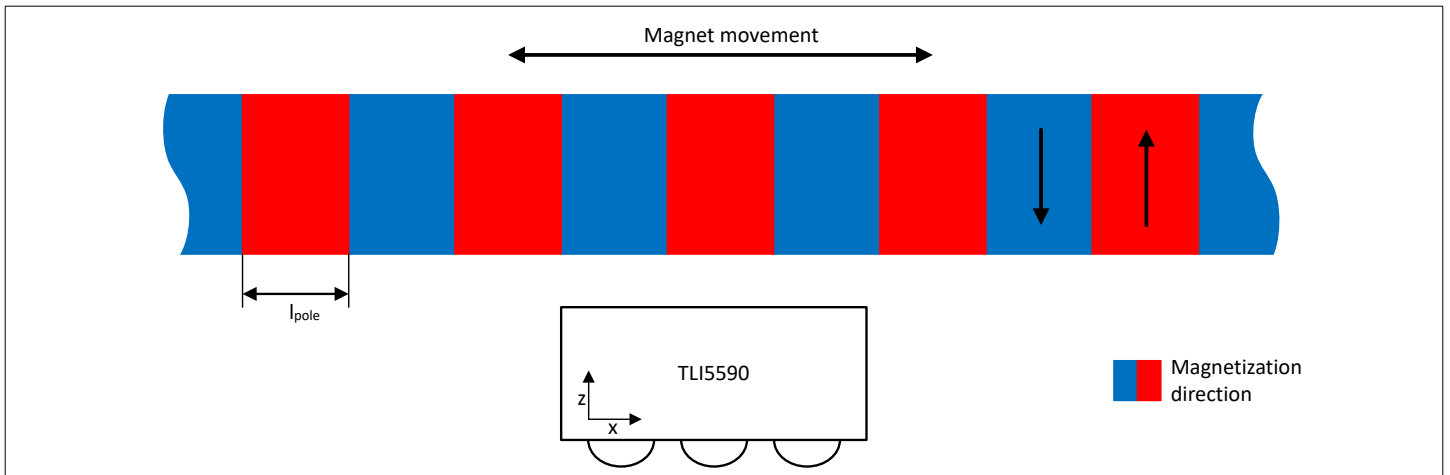

**Figure 5** TLI5590 with multipole magnet system setup

Due to the special architecture of the Wheatstone bridges the output signals of the sensor have different amplitudes (see [Figure 1](#) and [Table 7](#)). Regarding normalized out signals, the differential signal of bridge 2 has half the amplitude of the out signal from bridge 1 (see [Figure 6](#)). For position calculation it is necessary to multiply the output 2 with the factor of two.

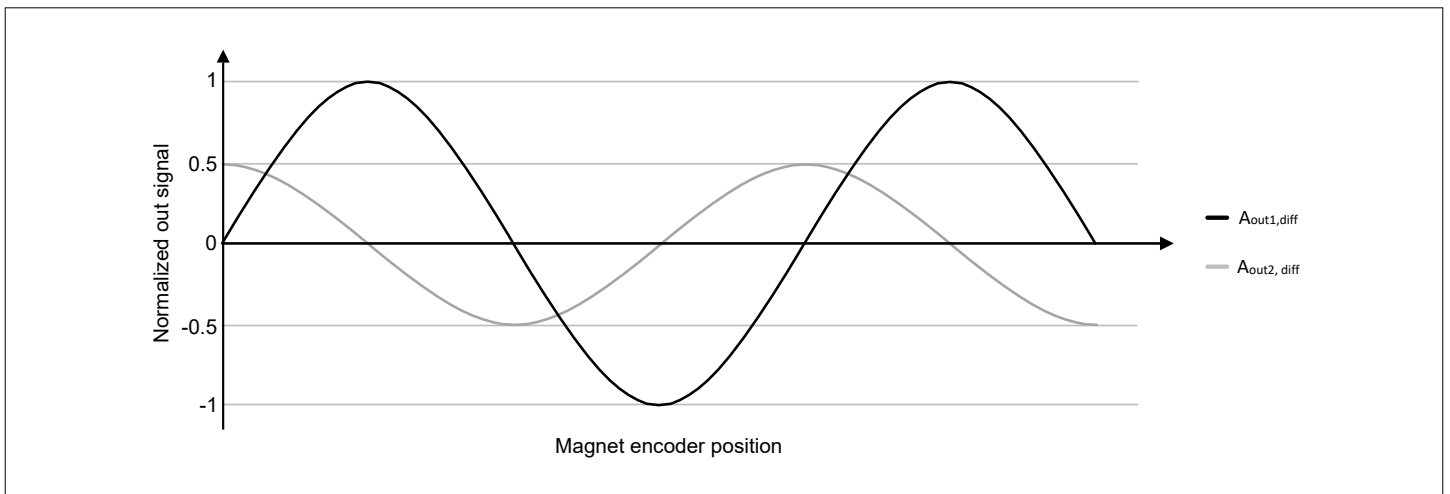

**Figure 6** TLI5590 normalized sensor out amplitudes when a multi pole magnet is passed by

## 6.2 Electrical characteristics

The indicated parameters apply to the full operating range, unless otherwise specified.  
Typical values correspond to a supply voltage  $V_{DD} = 3.3\text{ V}$  and  $T_A = 25^\circ\text{C}$ , unless individually specified.  
All specifications are valid over the full temperature range and over lifetime.

**Table 7** Electrical characteristics

Parameter	Symbol	Values			Unit	Note or condition
		Min.	Typ.	Max.		
Bridge resistance	$R_{\text{bridge}}$	4.62	6.6	8.58	kOhm	for $T_A = 25^\circ\text{C}$ , $B=0\text{mT}$ , <sup>1)</sup>
Temperature coefficient of bridge resistance	$TC_{\text{bridge}}$	-0.1	-0.07	-0.03	%/K	
Differential output voltage amplitude (bridge 1)	$A_{\text{out1, diff}}$	12	18.5	25	mV/V/mT	$A_{\text{out1, diff}} = VP1 - VN1$
Differential output voltage amplitude (bridge 2)	$A_{\text{out2, diff}}$	6	9	12.5	mV/V/mT	$A_{\text{out2, diff}} = VP2 - VN2$
Temperature coefficient of differential output voltage amplitude	$TC_{\text{Amp}}$	-0.1	-0.01	0.05	%/K	
Differential offset voltage	$V_{\text{off, diff}}$	-10	-	10	mV/V	
Temperature coefficient of offset voltage (differential ended)	$TC_{\text{off, diff}}$	-10	0	10	$\mu\text{V/V/K}$	

1) Resistance of each single Wheatstone bridge, see [Figure 1](#)

### 6.3 Residual measurement errors

**Table 8** Residual measurement errors

Parameter	Symbol	Values			Unit	Note or condition
		Min.	Typ.	Max.		
Residual angle error, $B \leq 1.5\text{mT}$	$A_{\text{err, res, } 1.5\text{mT}}$	-	$\pm 0.8$	$\pm 2.5$	$^{\circ}$	$B \leq 1.5\text{mT}$ ; with ideal compensation of offset and amplitude synchronicity, <sup>1)</sup>
Residual angle error	$A_{\text{err, res}}$	-	$\pm 2.0$	$\pm 4.1$	$^{\circ}$	$1.5 < B \leq 5\text{mT}$ ; with ideal compensation of offset and amplitude synchronicity, <sup>1)</sup>
Amplitude synchronism	$Amp_{\text{sync}}$	95	100	105	%	

1) Angle error if  $360^{\circ}$  corresponds to a travel of  $1000\mu\text{m}$  (= dipole length).

#### 6.3.1 Typical performance

Figure 7 shows the typical angle error with ideal compensation of offset and amplitude synchronicity.

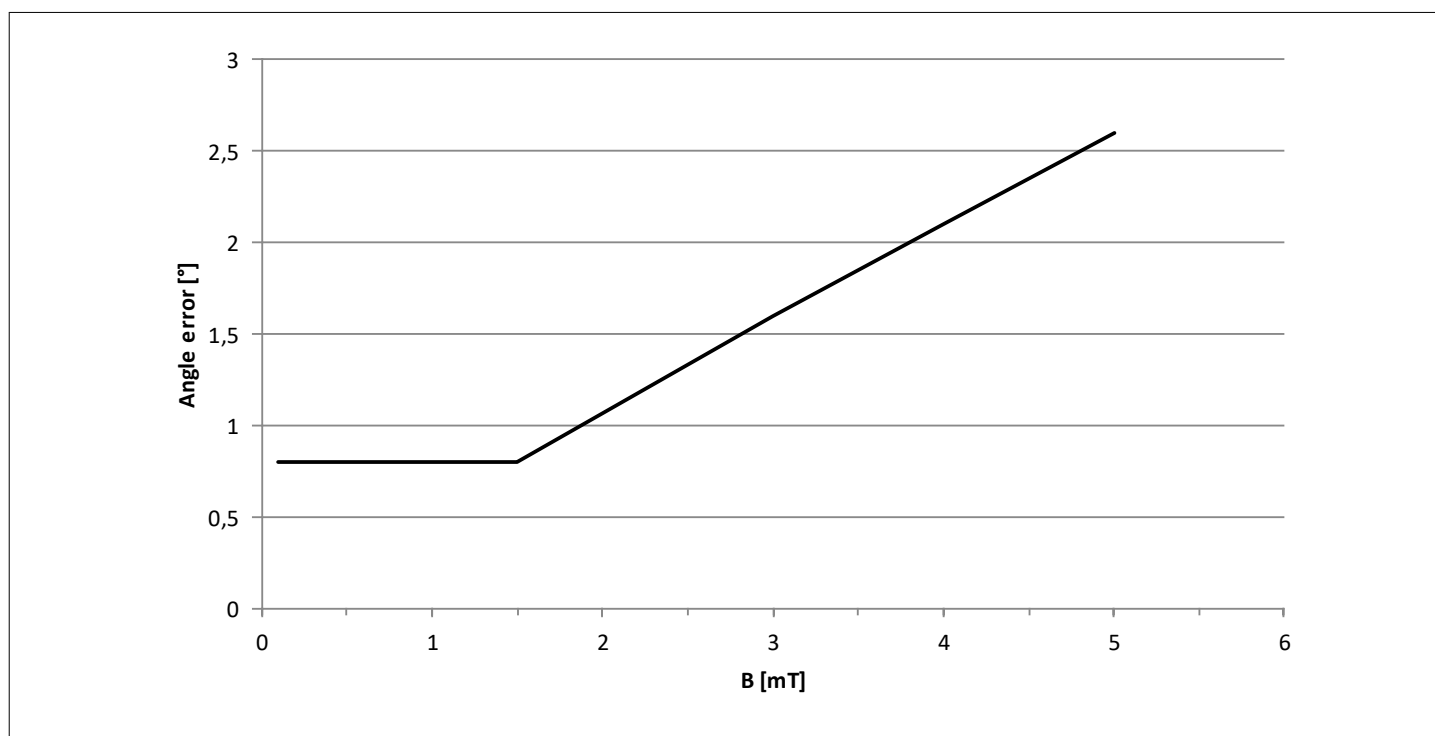

**Figure 7** Typical residual angle error

## 7 Application information

### 7.1 Magnet

In case of a linear movement measurement application, the used multipole magnet strip must fit to the sensor (see [Figure 5](#)). This means, the magnet pole length has to match to the distance of the TMR bridges inside the sensor. Please see [Table 9](#) for the correct pole length.

**Table 9**

Parameter	Symbol	Values			Unit	Note or condition
		Min.	Typ.	Max.		
Magnet pole pitch	$l_{\text{pole}}$	–	500	–	$\mu\text{m}$	Both ends of the magnet must have the same polarity. Both end poles must be a half pole (half pitch length)

## 8 Package

### 8.1 Package information

The package of the device is a wafer level package SG-WFWLB-6-3.

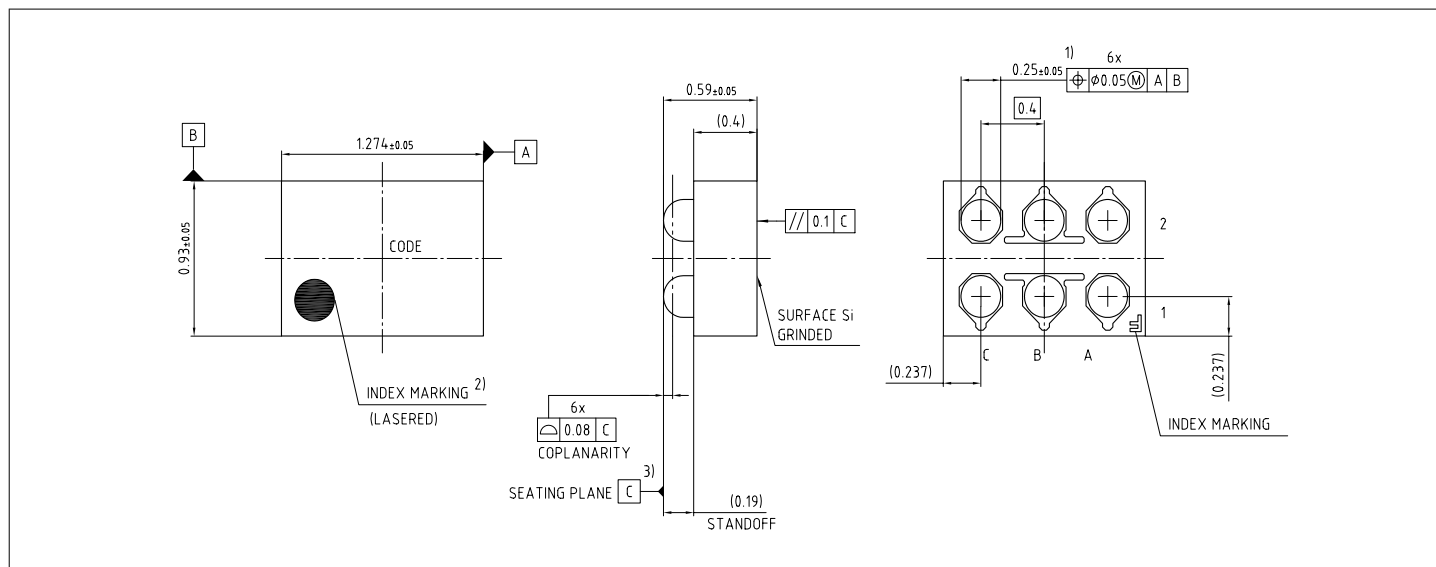

**Figure 8** Package dimensions

- 1) Dimension is measured at the maximum solder ball diameter, parallel to primary datum C.
- 2) Ball A1 corner identified by marking.
- 3) Primary datum C and seating plane are defined by the domed crowns of the balls.

The SG-WFWLB-6-3 package fulfills the MSL level 1 according to IPC/JEDEC J-STD-033B.1.

## 8.2 Packing

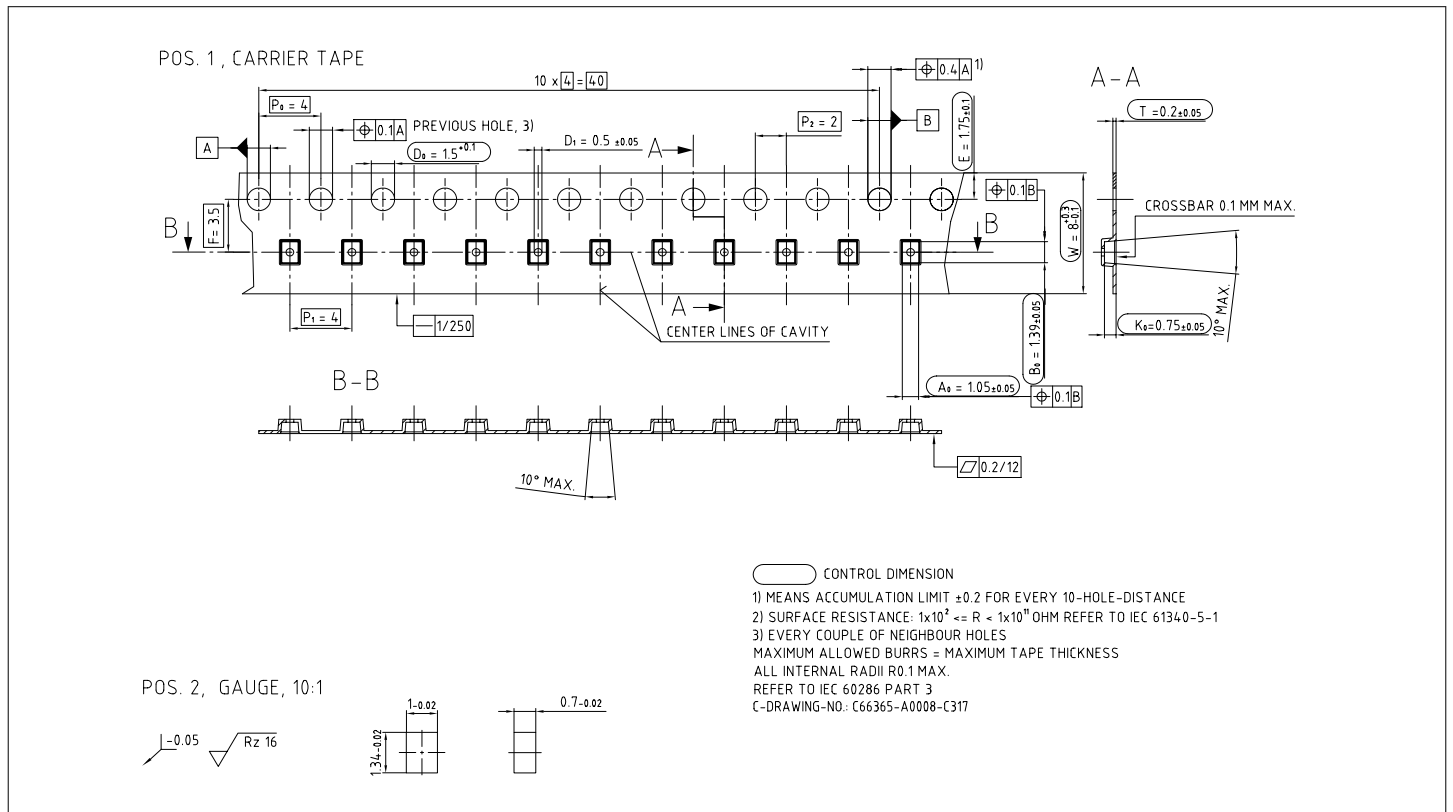

Figure 9 Packing

## 8.3 Additional package information

Further information about the package and processing can be found here:

<https://www.infineon.com/cms/en/product/packages/SG-WFWLB/>

## 9 Revision history

**Table 10**                      **Revision History**

<b>Document version</b>	<b>Date of release</b>	<b>Description of changes</b>
01.00	2022-12-09	Initial release

## Trademarks

All referenced product or service names and trademarks are the property of their respective owners.

**Edition 2022-12-09**

**Published by**

**Infineon Technologies AG**

**81726 Munich, Germany**

**© 2022 Infineon Technologies AG**

**All Rights Reserved.**

**Do you have a question about any aspect of this document?**

**Email: [erratum@infineon.com](mailto:erratum@infineon.com)**

**Document reference**

**IFX-gyh1657019754886**

## Important notice

The information given in this document shall in no event be regarded as a guarantee of conditions or characteristics ("Beschaffheitsgarantie").

With respect to any examples, hints or any typical values stated herein and/or any information regarding the application of the product, Infineon Technologies hereby disclaims any and all warranties and liabilities of any kind, including without limitation warranties of non-infringement of intellectual property rights of any third party.

In addition, any information given in this document is subject to customer's compliance with its obligations stated in this document and any applicable legal requirements, norms and standards concerning customer's products and any use of the product of Infineon Technologies in customer's applications.

The data contained in this document is exclusively intended for technically trained staff. It is the responsibility of customer's technical departments to evaluate the suitability of the product for the intended application and the completeness of the product information given in this document with respect to such application.

## Warnings

Due to technical requirements products may contain dangerous substances. For information on the types in question please contact your nearest Infineon Technologies office.

Except as otherwise explicitly approved by Infineon Technologies in a written document signed by authorized representatives of Infineon Technologies, Infineon Technologies' products may not be used in any applications where a failure of the product or any consequences of the use thereof can reasonably be expected to result in personal injury.