



## NJL5821R / NJL5822R

### Encoder with Optical Reflection Type

#### FEATURES

- Miniature, thin package: 2.6mm x 2.5mm x 0.8mm
- Digital two outputs type: A,B phases
- Operating temperature range: -30 to +105°C
- Resolution: NJL5821R 150LPI, NJL5822R 180LPI
- Pb free soldering re-flowing permitted: 255°C,2times
- Halogen free, Pb free
- Compliant with RoHS directive

#### GENERAL DESCRIPTION

NJL5821R/NJL5822R(Hereinafter referred to as NJL5821/22R) are the compact surface mount type photo reflector, which is built in a high brightness Infrared LED and PDIC. It can obtain two-phase(A,B) digital signals with the recommended striped reflector. It is the optimum sensor for various kinds of rotation detection, which can contribute to low power consumption of the set and simplification of the design.

#### APPLICATION

- Rotation detection of the operation dial
- Encoder

#### ORDERING INFORMATION

PRODUCT NAME	PACKAGE OUTLINE	RoHS	HALOGEN-FREE	TERMINAL FINISH	MARKING	WEIGHT (mg)	MOQ (pcs)
NJL5821R NJL5822R	COBP	Yes	Yes	Au	No marking	8.9	3000 (TE4) 500 (TE4F)

■ PIN DESCRIPTIONS

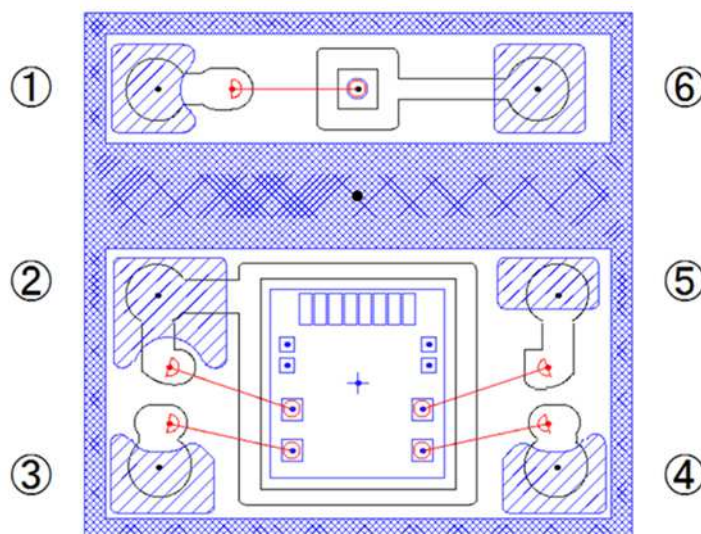

Pin Configuration

Pin No	Pin Name	Description
1	Cathode (LED)	Cathode for LED
2	GND	Ground
3	Vout2	Output Voltage 2
4	Vout1	Output Voltage 1
5	V <sub>CC</sub>	Power Supply
6	Anode (LED)	Anode for LED

■ ABSOLUTE MAXIMUM RATINGS

PARAMETER	SYMBOL	RATING	UNIT
Emitter			
Forward Current (Continuous)	I <sub>F</sub>	30	mA
Reverse Voltage (Continuous)	V <sub>R</sub>	6	V
Power Dissipation	P <sub>D</sub>	45	mW
Detector(PDIC)			
Supply Voltage	V <sub>CC</sub>	6.0	V
Power Dissipation	P <sub>PDIC</sub>	5	mW
Coupled			
Total Power Dissipation	P <sub>tot</sub>	50	mW
Operating Temperature	T <sub>opr</sub>	-30 to +105	°C
Storage Temperature	T <sub>stg</sub>	-30 to +110	°C
Reflow Soldering Temperature	T <sub>sol</sub>	255	°C

■ RECOMMENDED OPERATING CONDITIONS

PARAMETER	SYMBOL	VALUE	UNIT
Forward current	$I_F$	4 to 30	mA
Supply voltage	$V_{CC}$	+2.7 to +5.5	V
Scale pattern width(Direct reflection/Non-reflection)		0.085/0.085(NJL5821R) 0.070/0.070(NJL5822R)	mm

RECOMMENDED OPERATING CONDITIONS

All of electronic equipment should be designed that the mounted semiconductor devices operate within the recommended operating conditions. The semiconductor devices cannot operate normally over the recommended operating conditions, even if when they are used over such conditions by momentary electronic noise or surge. And the semiconductor devices may receive serious damage when they continue to operate over the recommended operating conditions.

■ ELECTRO-OPTICAL CHARACTERISTICS (Ta=25°C)

NJL5821/22R

PARAMETER	SYMBOL	TEST CONDITION	MIN	TYP	MAX	UNIT
Emitter						
Forward Voltage	$V_F$	$I_F=5mA$	0.9	1.4	1.8	V
Revers Voltage	$I_R$	$V_R=6V$	—	—	10	$\mu A$
Peak wavelength	$\lambda_P$		—	940	—	nm
Detector						
Supply Voltage	$V_{CC}$		2.7	3.0	5.5	V
Operating Current	$I_{CC}$	$V_{CC}=3V, In\ the\ dark$	—	150	300	$\mu A$
Coupled						
Minimum Operating Current	$I_{min}$	$V_{CC}=3.0V, d=1.0mm$	4	—	—	mA
High Level Output Voltage	$V_{oH}$	$I_F=5mA, V_{CC}=3.0V, d=1.0mm(Direct\ reflection)^{*1}$	$V_{CC}-0.5$	—	—	V
Low Level Output Voltage	$V_{oL}$	$I_F=5mA, V_{CC}=3.0V, d=1.0mm(Non-reflection)^{*1}$	—	—	GND+0.5	V
Phase Difference of output Voltage	$V_P$	$I_F=5mA, V_{CC}=3.0V, d=1.0mm$	—	90	—	deg
Duty ratio	Duty	$I_F=5mA, V_{CC}=3.0V, d=1.0mm$	—	50	—	%
Rise Time	$t_r$		—	0.1	—	$\mu sec$
Fall Time	$t_f$		—	0.1	—	$\mu sec$

\*1 Recommend the Linear scale NJL5821R:0.085mm/0.085mm

NJL5822R:0.070mm/0.070mm

※In the Electro-Optical characteristics table, items that are showed only the typical value are not tested in manufacturing process.

■ BLOCK DIAGRAMS

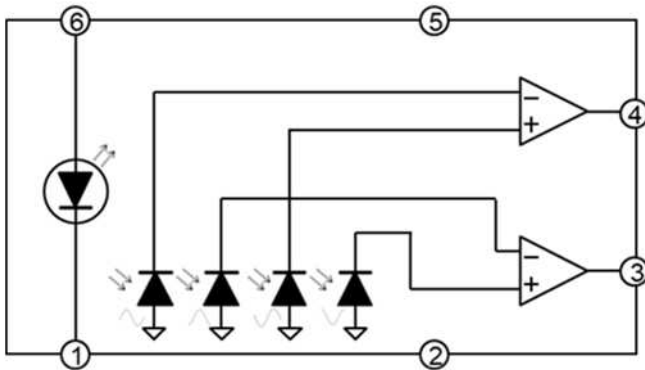

- 1. Cathode (LED)
- 2. GND
- 3. Vout2
- 4. Vout1
- 5. V<sub>CC</sub>
- 6. Anode (LED)

NJL5821/22R Block Diagram

■ APPLICATION NOTES

(1) Attention in handling

Treat not to touch the light receiving and light emitting part.

Avoid to adhering the dust and any other foreign materials on the light receiving and light emitting part when using. When LED has operated by voltage, it should be connected the resistor of current adjustment. Avoid to applying direct voltage to LED, because there is possibility that LED is destroyed.

When mounting, special care has to be taken on the mounting position and tilting of the device because it is very important to place the device to the optimum position to the object.

(2) Attention in designing

Avoid the entering ambient light into light receiving part for avoid the malfunction by ambient light. Furthermore, there is possibility of malfunction when there are the other mounted parts by near this product peripheral.

There will be changing characteristics by detection object. Refer to this datasheet and evaluate by actual detection object.

When LED has been applied continuous power on long period of time, the output current is dropped. If it uses by always applying power to LED, have to consider the circuit designing of including output current decrease.

■ TYPICAL CHARACTERISTICS

Note: Typical Characteristics are intended to be used as reference data; they are not guaranteed.

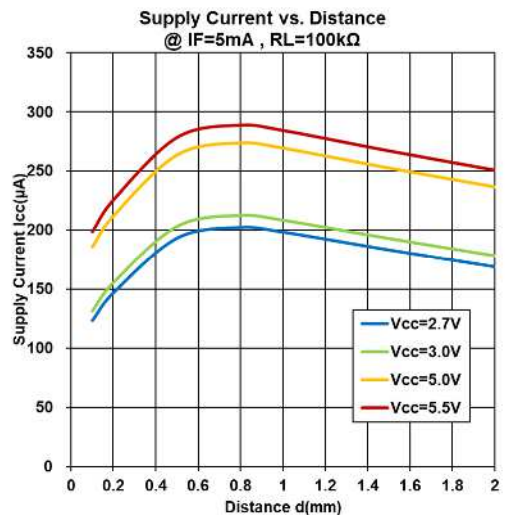
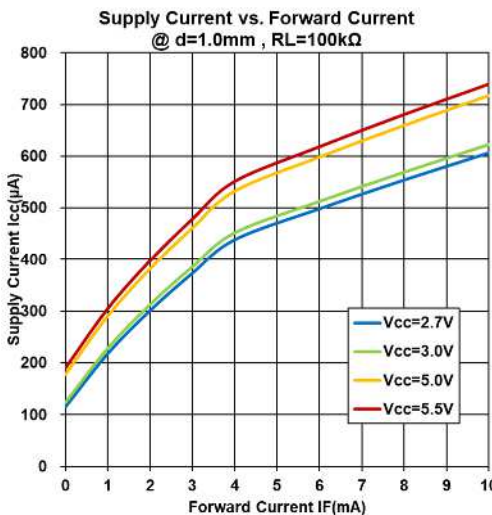
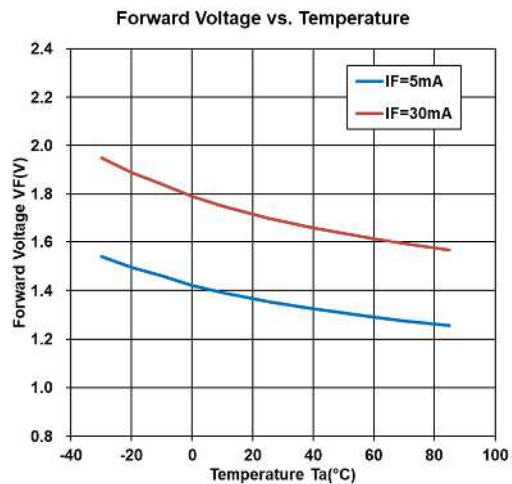
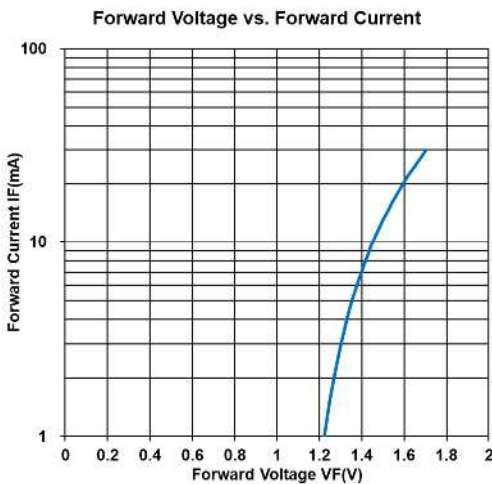
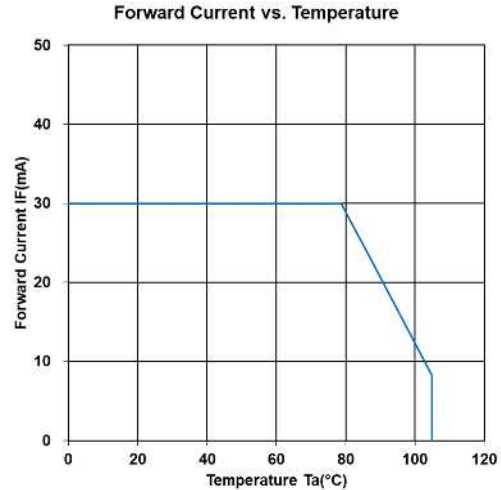
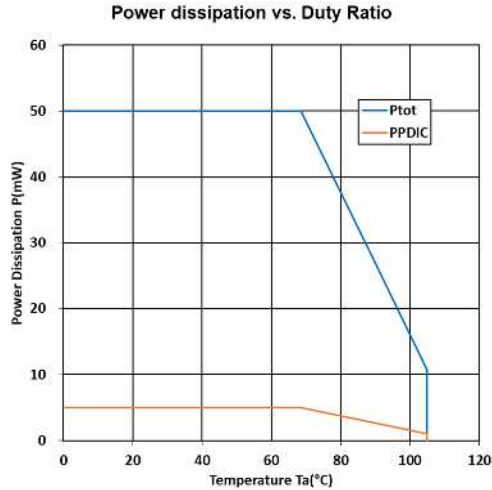

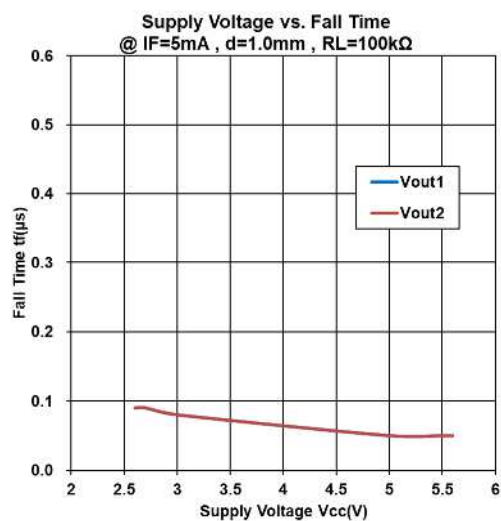
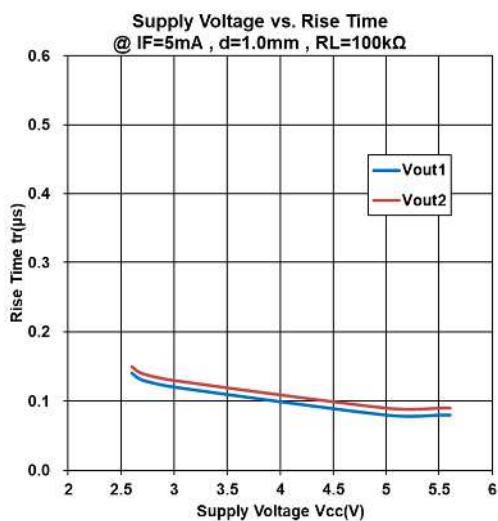
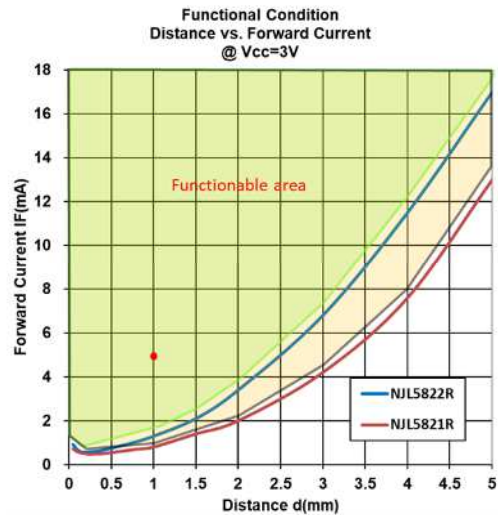
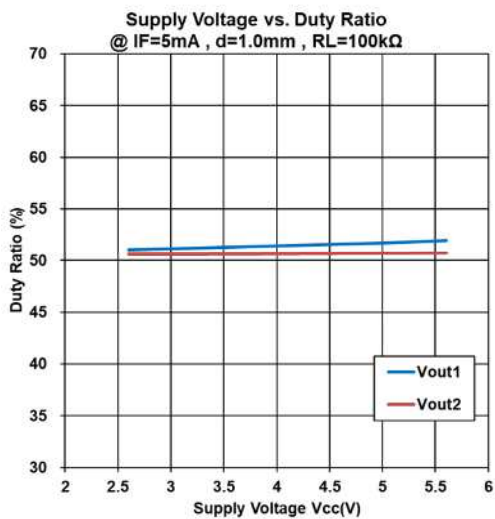
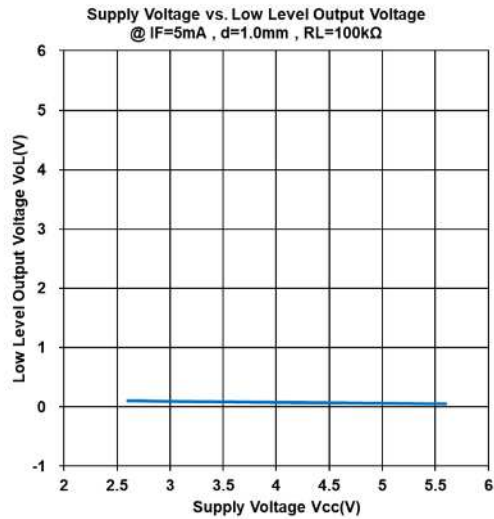
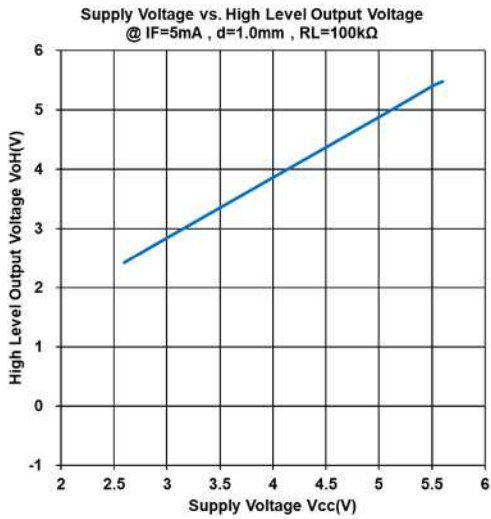

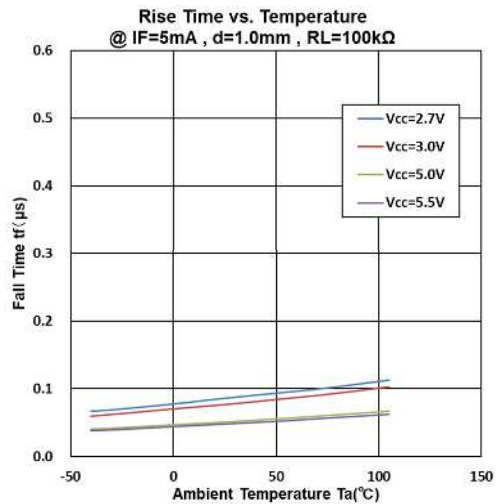
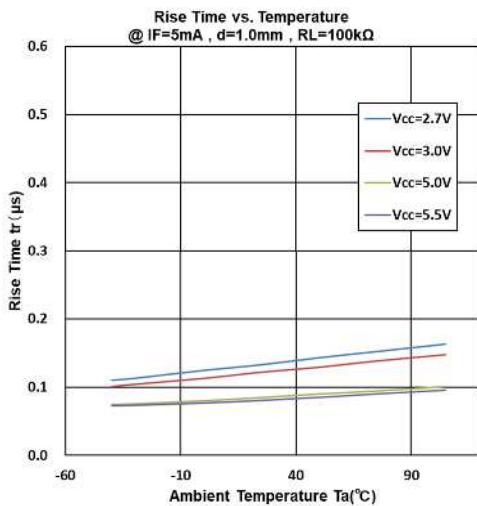
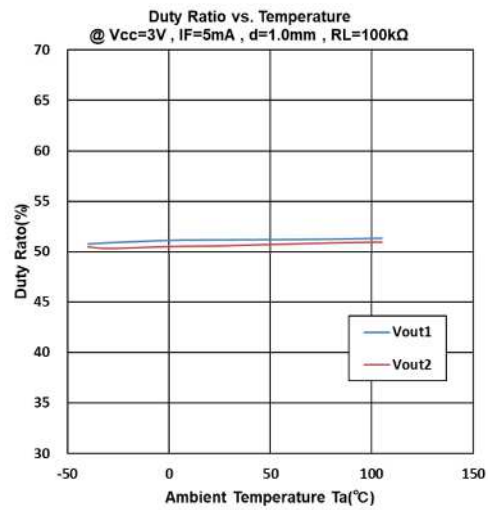
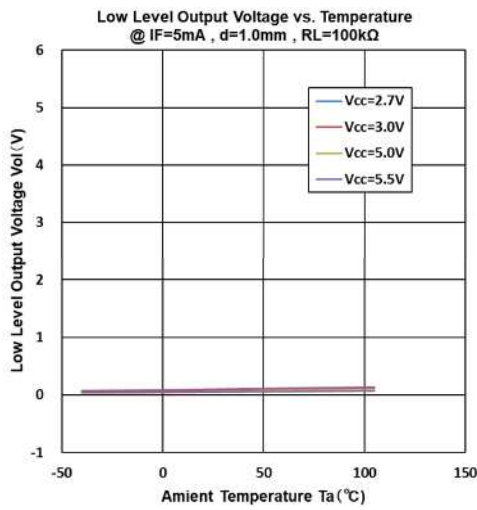
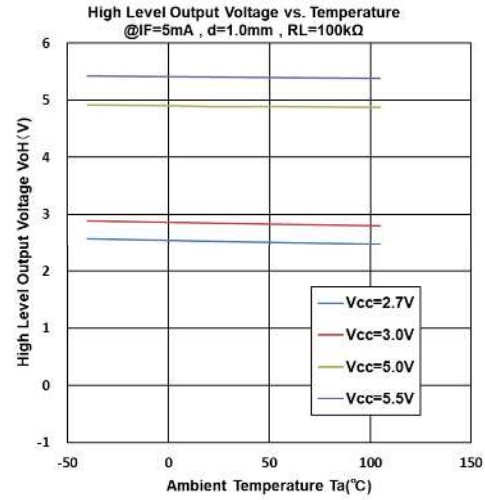
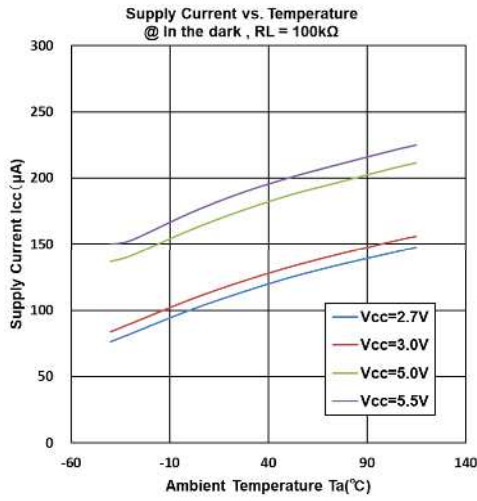

■ METHOD OF THE OUTPUT VOLTAGE MEASUREMENT

Output voltage measured using recommended Linear scale.

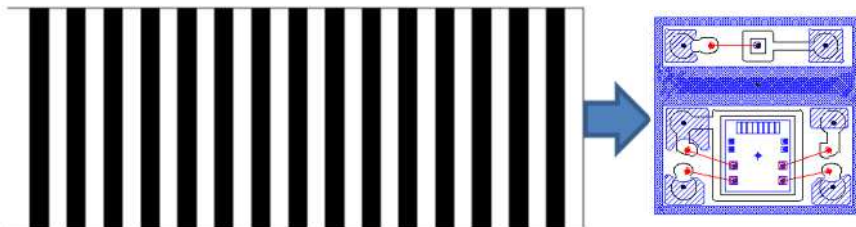

Linear scale NJL5821R : (0.085mm/0.085mm : Direct reflection/Non-reflection)  
 NJL5822R : (0.070mm/0.070mm : Direct reflection/Non-reflection)

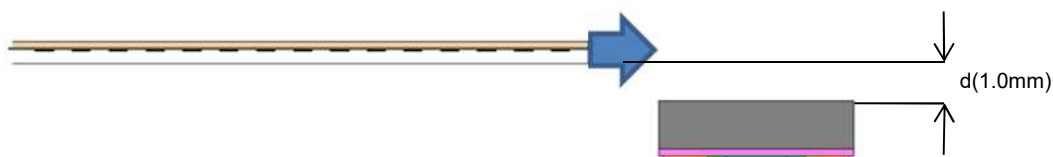

■ TEST CIRCUIT OF OUTPUT VOLTAGE

Output voltage measurement circuit diagram

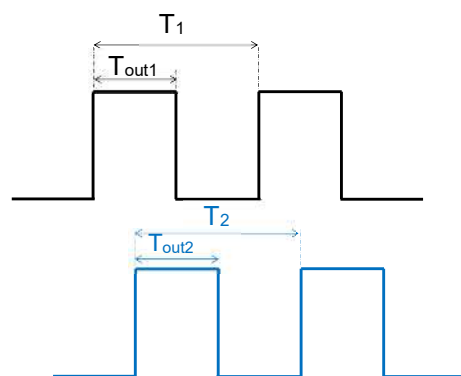
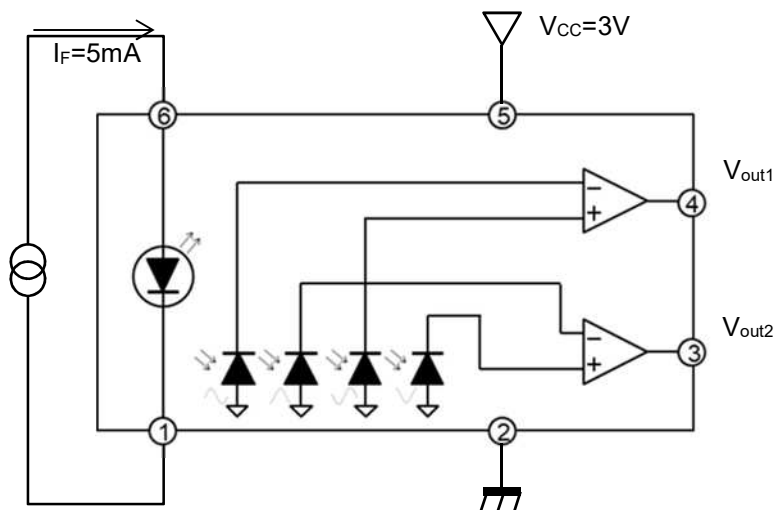

$$\text{Duty} = \frac{T_{\text{out1}}}{T_1}, \frac{T_{\text{out2}}}{T_2}$$



■ OPTICAL CENTER POSITION DEFINITION CHART

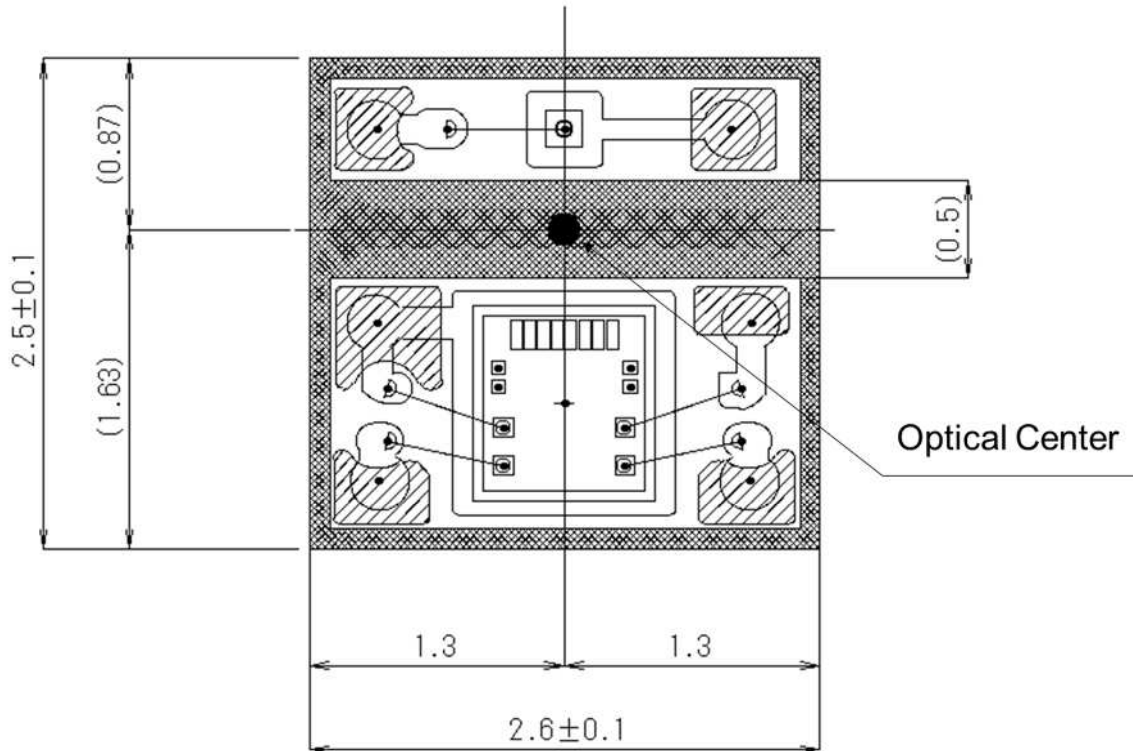

Table. Recommended Operating Conditions

PARAMETER	VALUE	UNIT
Scale pattern width(Direct reflection/Non-reflection)	0.085 / 0.085(NJL5821R) 0.070 / 0.070(NJL5822R)	mm

\*Please design so that the scale pattern width in the above recommended operating conditions table overlaps with the optical center in the above optical center position definition diagram.

\*When a rotary scale is used, the effect of misalignment in the Y-axis direction is greater than when a linear scale is used.

■ MEASUREMENT DEFINITION CHART

- Rotary scale misalignment evaluation

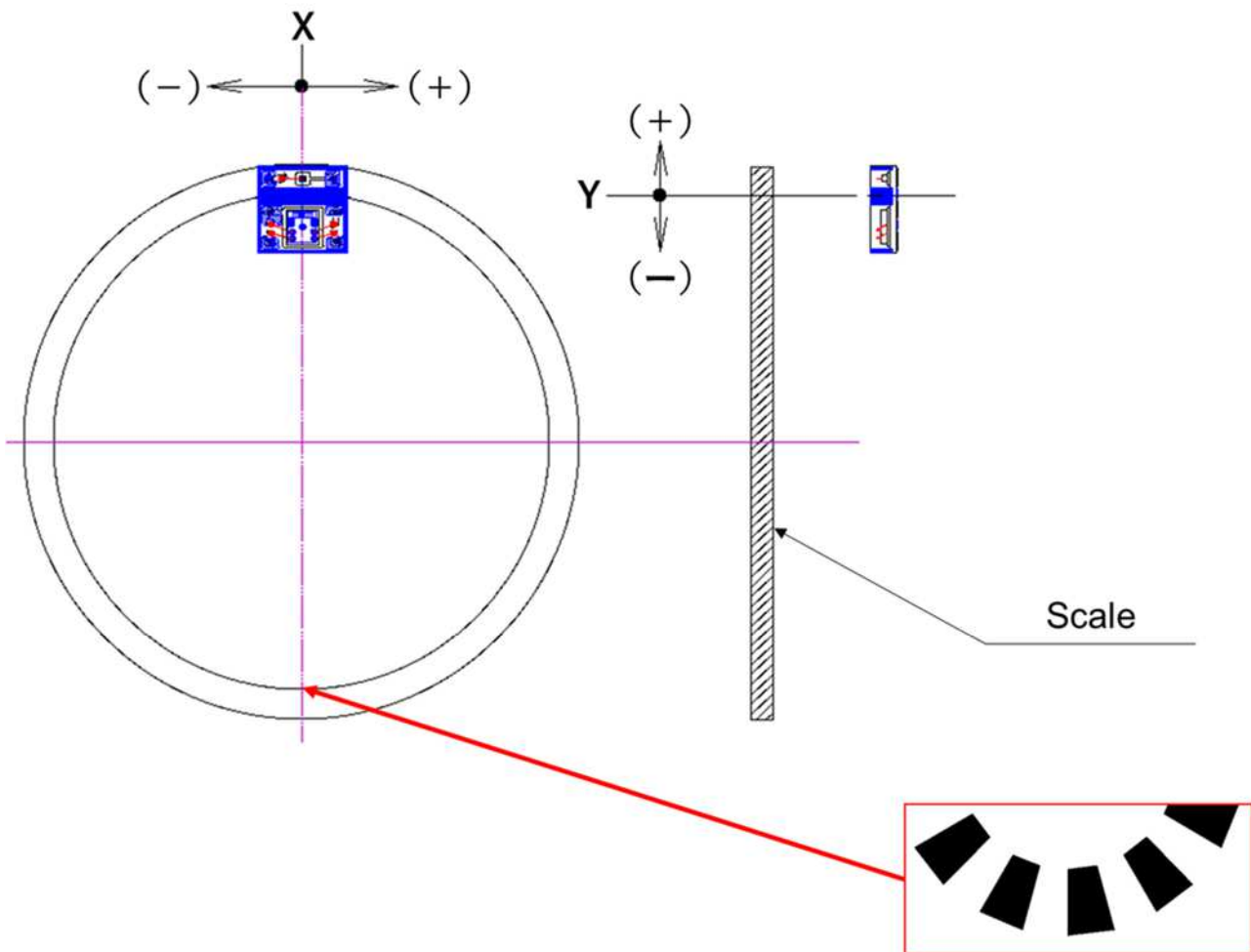

- Scale curvature dependence evaluation (center pattern width 0.070 / 0.070mm: \*NJL5822R measurement)

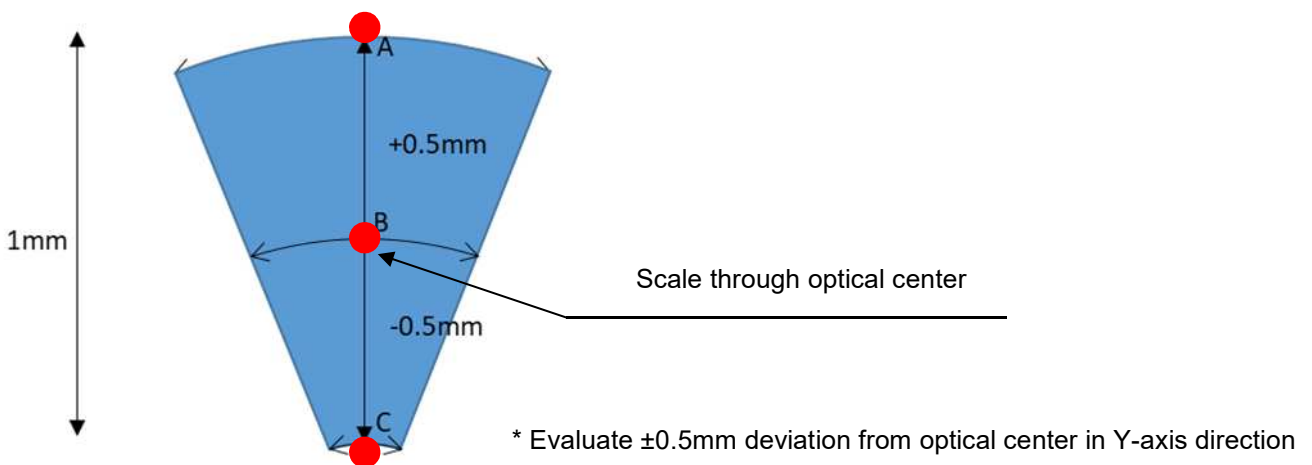

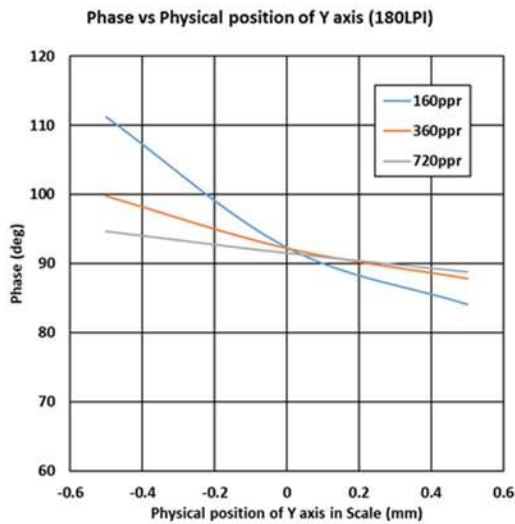
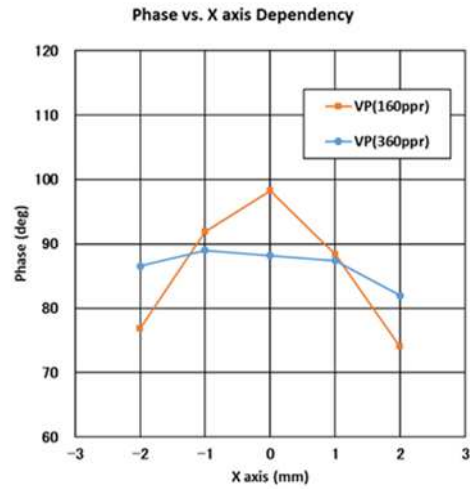
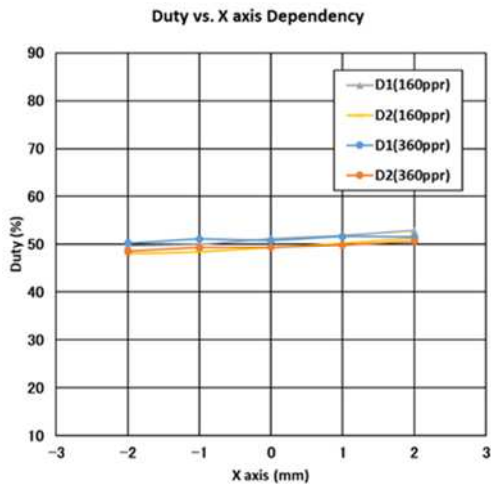

● Rotary scale diameter reference table

PARAMETER	ROTARY SCALE DIAMETER
160ppr	Φ12 (NJL5821R) Φ10 (NJL5822R)
360ppr	Φ22 (NJL5821R) Φ20 (NJL5822R)
720ppr	Φ42 (NJL5821R) Φ36 (NJL5822R)

\*Please contact us when considering rotary scale diameters of 160ppr or less

## ■ REVISION HISTORY

Date	Revision	Changes
July 19th, 2022	Ver. 1.0	Initial release

# Nisshinbo Micro Devices Inc.

ACOB06-CHZ-3 (COBP)

PI-ACOB06-CHZ-3-E-A

## ■ PACKAGE DIMENSIONS

UNIT: mm

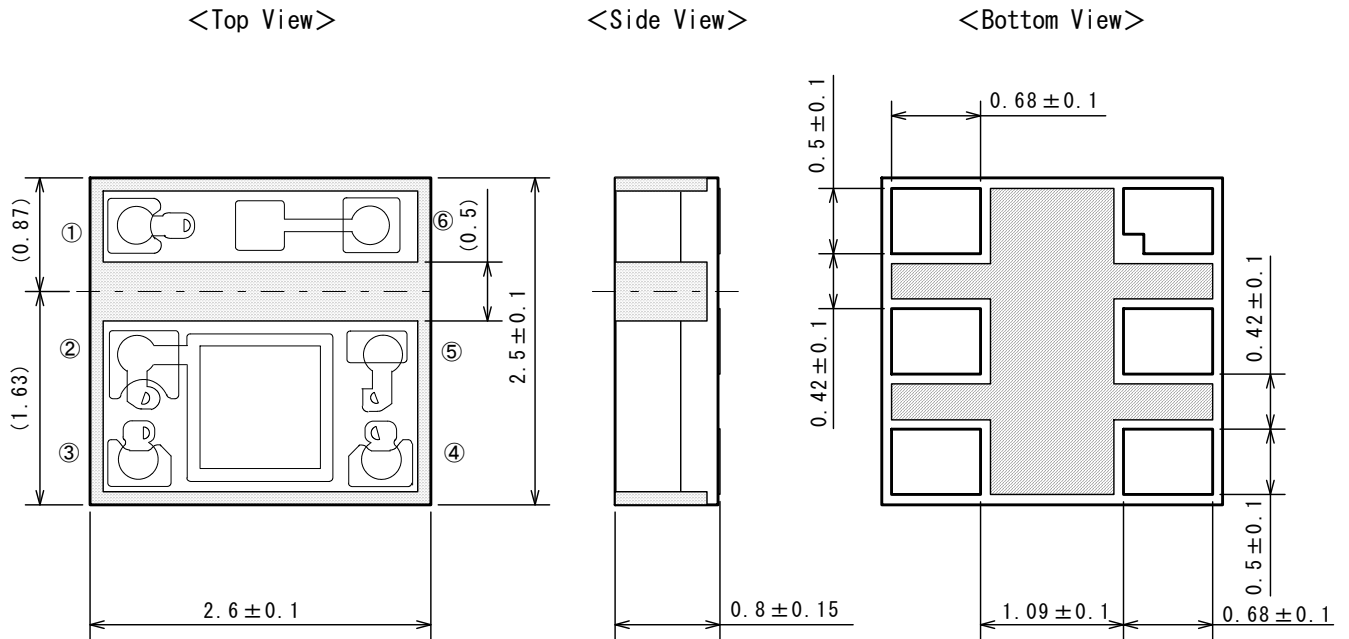

## ■ EXAMPLE OF SOLDER PADS DIMENSIONS

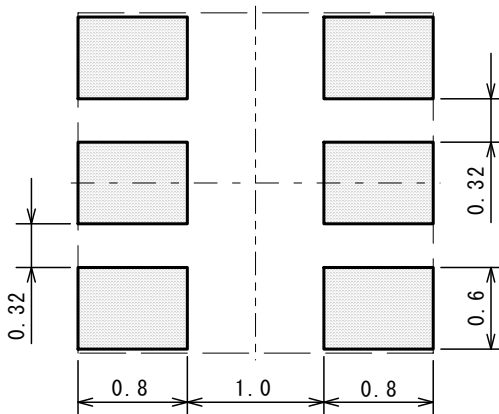

# Nisshinbo Micro Devices Inc.

ACOB06-CHZ-3 (COBP)

PI-ACOB06-CHZ-3-E-A

■ PACKING SPEC

UNIT: mm

(1) Taping dimensions / Insert direction

Carrier tape material: PC  
Cover tape material: PET

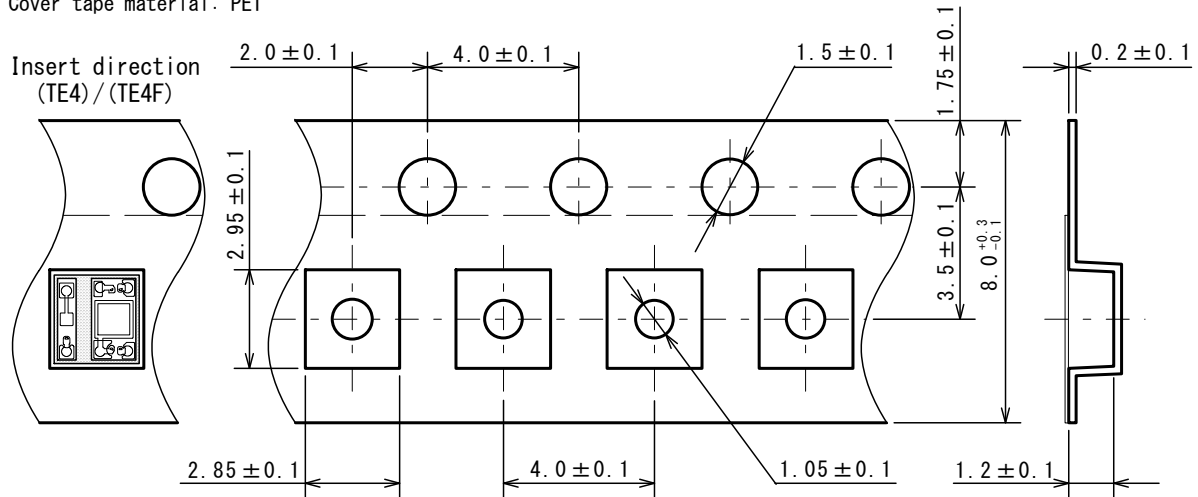

(2) Taping state

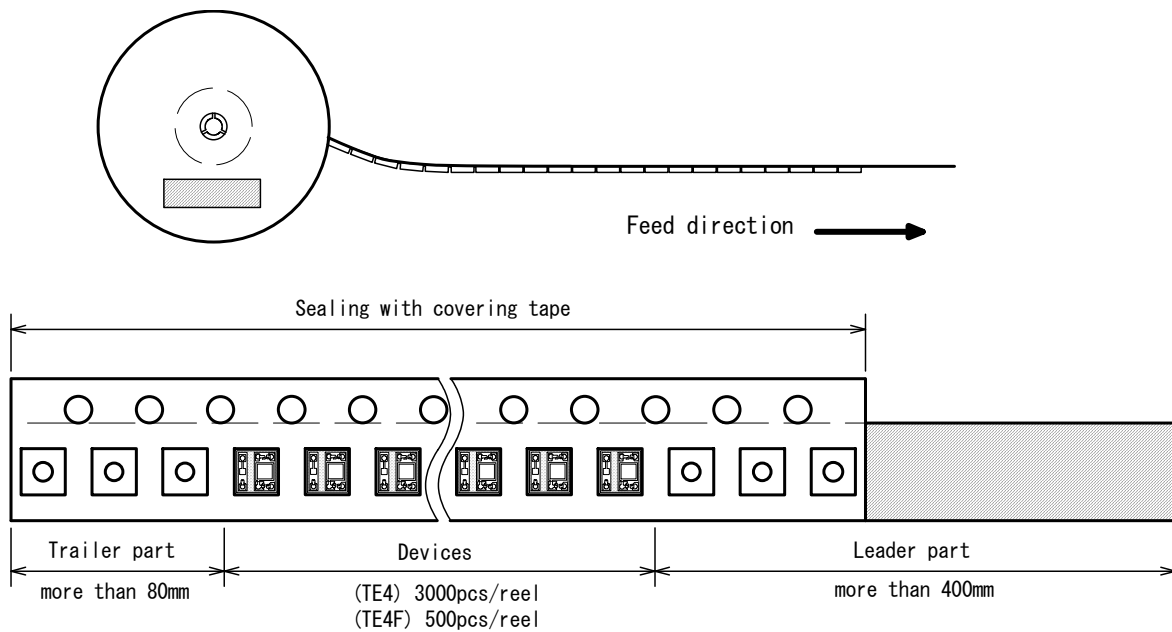

(3) Reel dimensions

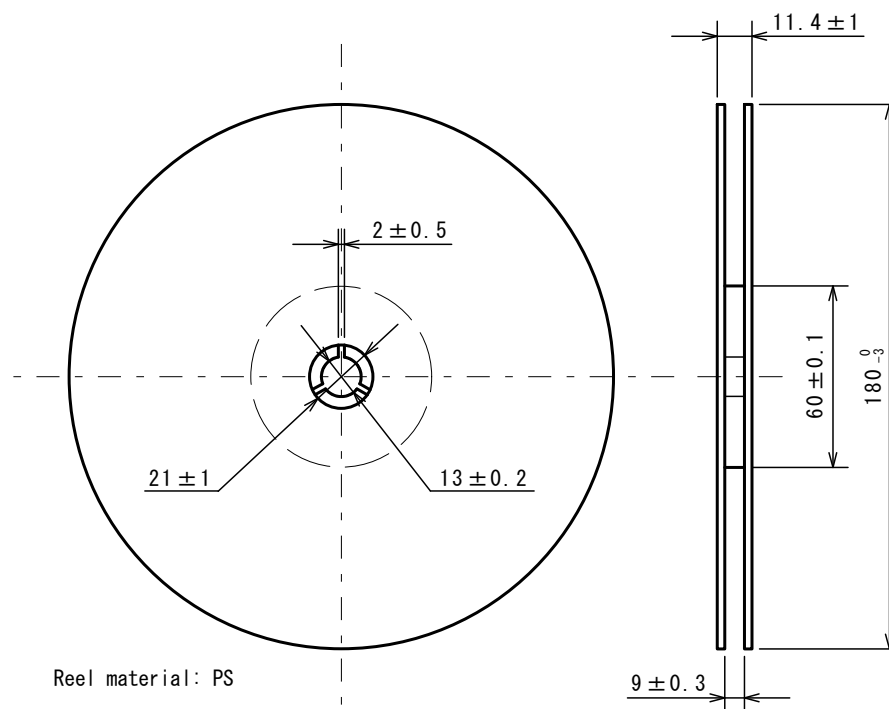

(4) Peeling strength

Peeling strength of cover tape

- Peeling angle 165 to 180° degrees to the taped surface.
- Peeling speed 300mm/min
- Peeling strength 0.1 to 1.3N

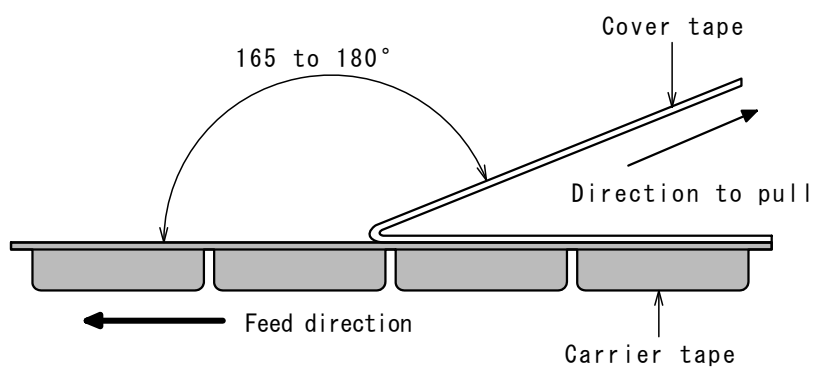

# Nisshinbo Micro Devices Inc.

ACOB06-CHZ-3 (COBP)

PI-ACOB06-CHZ-3-E-A

(5) Packing state

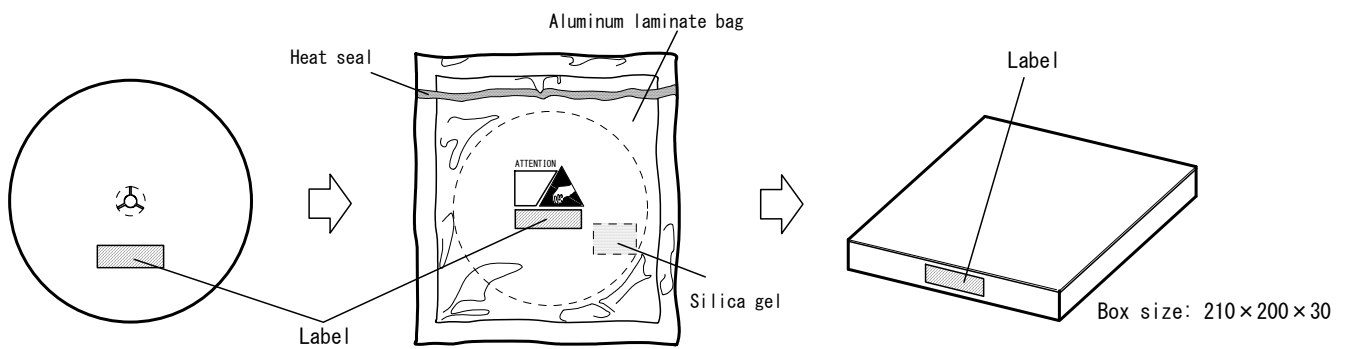

(6) Label

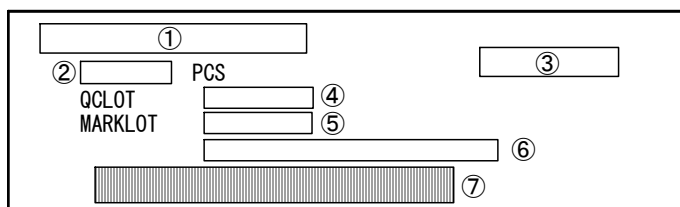

①	Product name
②	Quantity
③	Product code
④	QC LOT No.
⑤	(Blank)
⑥	Environmental notation
⑦	Barcode



## ■ HEAT-RESISTANCE PROFILES

(NOTE)

Mounting was evaluated with the following profiles in our company, so there was no problem. However, confirm mounting by the condition of your company beforehand.

The exposure of device under higher temperature may affect to the reliability of the products, it is recommended to complete soldering in the shortest time possible.

Mounting: Two Times soldering is allowed.

### REFLOW SOLDERING METHOD

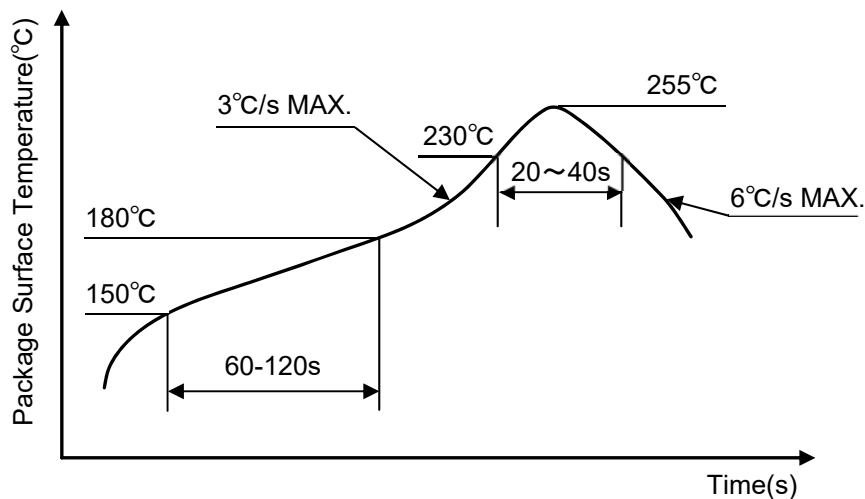

(Note1) Using reflow furnace with short wave infrared radiation heater such as halogen lamp.

Regarding temperature profile, please refer to those for reflow furnace.

In this case the resin surface temperature may become higher than lead terminals due to endothermic ally of black colored mold resin. Therefore, please avoid from direct exposure to mold resin.

(Note2) Other method

Such other methods of soldering as dipping the device the device into melted solder and vapor phase method (VPS) are not appropriate because the body of device will be heated rapidly. Therefore, these are not recommended to apply.

(Note3) The resin gets softened right after soldered, so, the following care has to be taken.

Not to contact the lens surface to anything.

Not to dip the device into water or any solvents.

### FLOW SOLDERING METHOD

\*Flow soldering is not possible.

### IRON SOLDERING METHOD

\*Iron soldering not possible.

## ■ CLEANING CONDITIONS

Please refrain from cleaning of the device as much as possible.

Be careful to avoid solvents or the vapor of solvents attach the resin devices even during the mounting and using.

## ■ IC STRAGE CONDITIONS AND ITS DURATION

### (1) Temperature and humidity ranges

Pack Sealing    Temperature:    5 to 40 [°C]

                         Humidity:            40 to 80 [%]

Pack Opening    Temperature:    5 to 30 [°C]

                         Humidity:            40 to 70 [%]

After opening the bag, solder products within 48 hours.

Avoid a dry environment below 40% because the products are easily damageable by the electrical discharge.

Store the products in the place where it does not create dew with the products due to a sudden change in temperature.

(2) When baking, place the reel vertically to avoid load to the side.

(3) Do not store the devices in a corrosive-gas atmosphere.

(4) Do not store the devices in a dusty place.

(5) Do not expose the devices to direct rays of the sun.

(6) Do not allow external forces or loads to be applied to ICs.

(7) Be careful because affixed label on the reel might be peeled off when baking.

## ■ BAKING

In case of keeping except above condition, be sure to apply baking. (Heat-resistant tape)

Baking Method:    Ta=60(°C) , 48 to 72(h), one time baking is allowed

1. The products and the product specifications described in this document are subject to change or discontinuation of production without notice for reasons such as improvement. Therefore, before deciding to use the products, please refer to our sales representatives for the latest information thereon.
2. The materials in this document may not be copied or otherwise reproduced in whole or in part without the prior written consent of us.
3. This product and any technical information relating thereto are subject to complementary export controls (so-called KNOW controls) under the Foreign Exchange and Foreign Trade Law, and related politics ministerial ordinance of the law. (Note that the complementary export controls are inapplicable to any application-specific products, except rockets and pilotless aircraft, that are insusceptible to design or program changes.) Accordingly, when exporting or carrying abroad this product, follow the Foreign Exchange and Foreign Trade Control Law and its related regulations with respect to the complementary export controls.
4. The technical information described in this document shows typical characteristics and example application circuits for the products. The release of such information is not to be construed as a warranty of or a grant of license under our or any third party's intellectual property rights or any other rights.
5. The products listed in this document are intended and designed for use as general electronic components in standard applications (office equipment, telecommunication equipment, measuring instruments, consumer electronic products, amusement equipment etc.). Those customers intending to use a product in an application requiring extreme quality and reliability, for example, in a highly specific application where the failure or misoperation of the product could result in human injury or death should first contact us.
  - Aerospace Equipment
  - Equipment Used in the Deep Sea
  - Power Generator Control Equipment (nuclear, steam, hydraulic, etc.)
  - Life Maintenance Medical Equipment
  - Fire Alarms / Intruder Detectors
  - Vehicle Control Equipment (automotive, airplane, railroad, ship, etc.)
  - Various Safety Devices
  - Traffic control system
  - Combustion equipment

In case your company desires to use this product for any applications other than general electronic equipment mentioned above, make sure to contact our company in advance. Note that the important requirements mentioned in this section are not applicable to cases where operation requirements such as application conditions are confirmed by our company in writing after consultation with your company.

6. We are making our continuous effort to improve the quality and reliability of our products, but semiconductor products are likely to fail with certain probability. In order to prevent any injury to persons or damages to property resulting from such failure, customers should be careful enough to incorporate safety measures in their design, such as redundancy feature, fire containment feature and fail-safe feature. We do not assume any liability or responsibility for any loss or damage arising from misuse or inappropriate use of the products.
7. The products have been designed and tested to function within controlled environmental conditions. Do not use products under conditions that deviate from methods or applications specified in this datasheet. Failure to employ the products in the proper applications can lead to deterioration, destruction or failure of the products. We shall not be responsible for any bodily injury, fires or accident, property damage or any consequential damages resulting from misuse or misapplication of the products.
8. **Quality Warranty**
  - 8-1. **Quality Warranty Period**

In the case of a product purchased through an authorized distributor or directly from us, the warranty period for this product shall be one (1) year after delivery to your company. For defective products that occurred during this period, we will take the quality warranty measures described in section 8-2. However, if there is an agreement on the warranty period in the basic transaction agreement, quality assurance agreement, delivery specifications, etc., it shall be followed.
  - 8-2. **Quality Warranty Remedies**

When it has been proved defective due to manufacturing factors as a result of defect analysis by us, we will either deliver a substitute for the defective product or refund the purchase price of the defective product.

Note that such delivery or refund is sole and exclusive remedies to your company for the defective product.
  - 8-3. **Remedies after Quality Warranty Period**

With respect to any defect of this product found after the quality warranty period, the defect will be analyzed by us. On the basis of the defect analysis results, the scope and amounts of damage shall be determined by mutual agreement of both parties. Then we will deal with upper limit in Section 8-2. This provision is not intended to limit any legal rights of your company.
9. Anti-radiation design is not implemented in the products described in this document.
10. The X-ray exposure can influence functions and characteristics of the products. Confirm the product functions and characteristics in the evaluation stage.
11. WLCSP products should be used in light shielded environments. The light exposure can influence functions and characteristics of the products under operation or storage.
12. Warning for handling Gallium and Arsenic (GaAs) products (Applying to GaAs MMIC, Photo Reflector). These products use Gallium (Ga) and Arsenic (As) which are specified as poisonous chemicals by law. For the prevention of a hazard, do not burn, destroy, or process chemically to make them as gas or power. When the product is disposed of, please follow the related regulation and do not mix this with general industrial waste or household waste.
13. Please contact our sales representatives should you have any questions or comments concerning the products or the technical information.



**Nisshinbo Micro Devices Inc.**

**Official website**

<https://www.nisshinbo-microdevices.co.jp/en/>

**Purchase information**

<https://www.nisshinbo-microdevices.co.jp/en/buy/>