



GPRS /GSM SIM900A MODEM

USER MANUAL

Contents

Overview.....	4
GSM GPRS SIM900A Modem	4
Features.....	5
Datasheets	5
GSM Utility Software.....	6
Basic AT Commands for Testing	7
GSM AT Commands:	Error! Bookmark not defined.
GPRS Commands:	Error! Bookmark not defined.
MODULE SETUP	9
POWER MODES.....	12
Power down mode.....	12
Minimum Functionality Mode.....	12
Sleep mode.....	12
Wake up SIM900A from sleep mode	12
PINS OF GSM SIM900A Modem.....	13
NARATION OF GSM SIM900A MODEM.....	14
BLOCK DIAGRAMS.....	15
INTERFACING UNO AND GSM SHIELD.....	15
INTERFACING RASPBERRY AND GSM SHIELD	16
INTERFACING BEAGLEBOARD AND GSM SHIELD	17
INTERFACING MICROCONTROLLER WITH GSM SHIELD.....	18
CODES	19
ARM CODE.....	19
ATMEL CODE.....	19
PIC CODE	19
ARDUNIO CODE	19
RASPBERRY PI CODE.....	19
BEAGLEBONE CODE	19
MSP430 CODE.....	19



GSM POWER SAVING ATMEL CODE	19
GSM POWER SAVING PIC CODE.....	19
MODULE HANDLING	20
DO'S AND DONT'S	20

Overview

GSM GPRS SIM900A Modem

GSM/GPRS Modem-RS232 is built with Dual Band GSM/GPRS engine- SIM900A, works on frequencies 900/ 1800 MHz. The Modem is coming with RS232 interface, which allows you connect PC as well as microcontroller with RS232 Chip(MAX232). The baud rate is configurable from 9600-115200 through AT command. The GSM/GPRS Modem is having internal TCP/IP stack to enable you to connect with internet via GPRS. It is suitable for SMS, Voice as well as DATA transfer application in M2M interface. The onboard Regulated Power supply allows you to connect wide range unregulated power supply . Using this modem, you can make audio calls, SMS, Read SMS, attend the incoming calls and internet through simple AT commands

Features

- Dual-Band GSM/GPRS 900/ 1800 MHz.
- RS232 interface for direct communication with computer or MCU kit.
- Configurable baud rate.
- Power controlled using 29302WU IC.
- ESD Compliance.
- Enable with MIC and SPeaker socket.
- With slid in SIM card tray.
- With Stub antenna and SMA connector.
- Input Voltage: 12V DC.

Datasheets

- AT Commands datasheet
<https://drive.google.com/a/researchdesignlab.com/file/d/0BzrGD4zr88GnTkJwSll3dnhKbTg/edit?usp=sharing>
- FTP Commands datasheet
<https://drive.google.com/a/researchdesignlab.com/file/d/0BzrGD4zr88GnVkhacjUtY2tIU2c/edit?usp=sharing>
- TCP/IP Commands datasheet
<https://drive.google.com/a/researchdesignlab.com/file/d/0BzrGD4zr88GnUHRCQIJwUjdWTVU/edit?usp=sharing>

GSM Utility Software

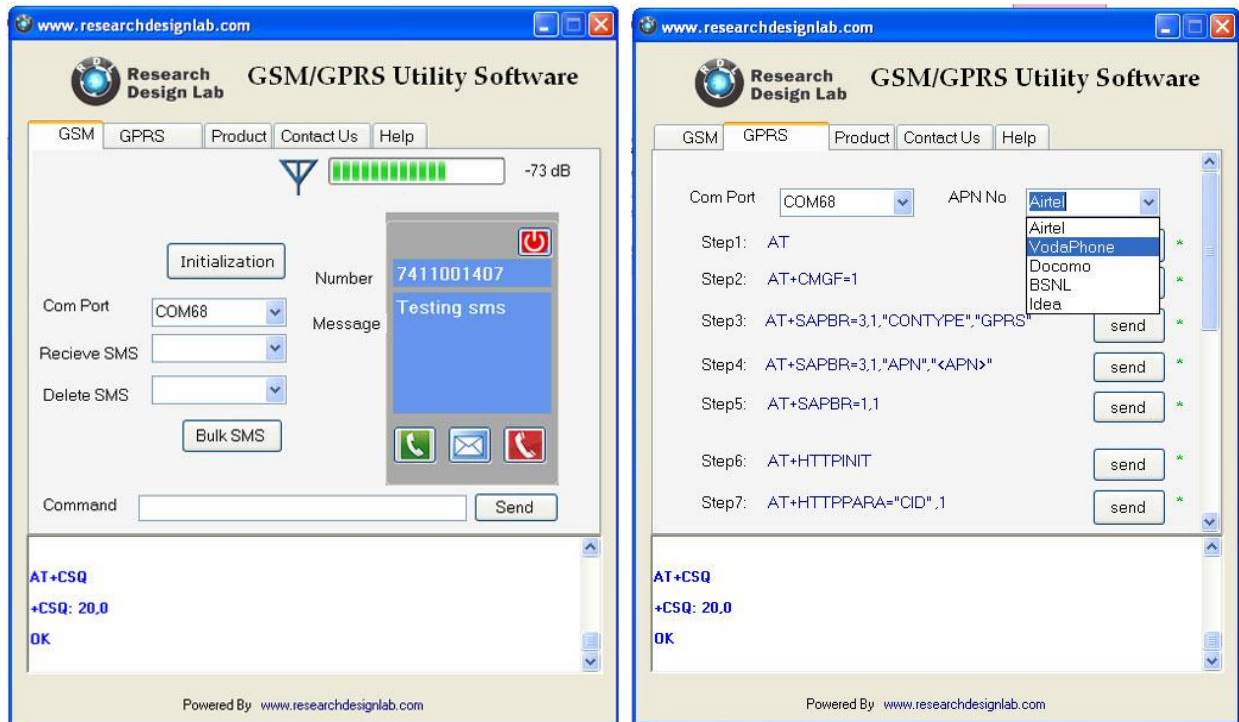

- Bulk Message sending
- AT command testing terminal
- Provides step by step GPRS setup

To download GSM/GPRS Utility software ,click on the link below

- <https://docs.google.com/file/d/0BzrGD4zr88GnYll6dlFJT2NFY2s/edit>
- http://www.4shared.com/file/rwyHmtGOBa/GSM_GPRS_utility.html

Basic AT Commands for Testing

GSM AT Commands:

- TO CHECK THE MODEM:
AT ↵
OK
- TO CHANGE SMS SENDING MODE:
AT+CMGF=1 ↵
OK
- TO SEND NEW SMS:
AT+CMGS="MOBILE NO." ↵
<MESSAGE
{CTRL+Z}
- TO RECEIVE SMS
AT+CMGD=1 ↵ {to delete the message in buffer}
AT+CMGR=1 ↵ {to receive first message AT+CMGR=1}
{to receive second message AT+CMGR=2 and so on}
+CMGL: 1,"REC READ","+85291234567",,"07/05/01,08:00:15+32",145,37
<MESSAGE
- PREFERRED SMS MESSAGE STORAGE:
AT+CPMS=? ↵
+CPMS: ("SM"),("SM"),("SM")
OK
AT+CPMS? ↵
+CPMS: "SM",19,30,"SM",19,30,"SM",19,30
- TO MAKE A VOICE CALL:
ATD9876543210; ↵
- TO REDIAL LAST NO:
ATDL ↵
- TO RECEIVE INCOMING CALL:
ATA ↵
- TO HANGUP OR DISCONNECT A CALL:
ATH ↵
- TO SET A PARTICULAR BAUDRATE:
AT+IPR=? ↵ {To view the baud rate values}
AT+IPR=0 ↵ {To set the modem to autobauding mode}
- OPERATOR SELECTION:
AT+COPS=? ↵
OK
AT+COPS? ↵
+COPS: 0,0,"AirTel"
OK

- AT+CRC SET CELLULAR RESULT CODES FOR INCOMING CALL INDICATION:
AT+CRC=? ↓
+CRC: (0-1)
OK
AT+CRC? ↓
+CRC: 0
OK
AT+CRC=1 ↓
OK
+CRING: VOICE
- READ OPERATOR NAMES.
AT+COPN=? ↓
OK
AT+COPN ↓
+COPN: "472001","DHIMOBILE"
+COPN: "60500"
+COPN: "502012","maxis mobile"
+COPN:
+COPN: "502013","TMTOUCH"
+COPN
+COPN: "502016","DiGi"
+COPN: "502017","TIMECel"
+COPN: "502019","CELCOM GSM"

GPRS Commands:

<u>Command</u>	<u>Description</u>
AT+CGATT ↓	ATTACH/DETACH FROM GPRS SERVICE
AT+CGDCONT ↓	DEFINE PDP CONTEXT
AT+CGQMIN ↓	QUALITY OF SERVICE PROFILE (MINIMUM ACCEPTABLE)
AT+CGQREQ ↓	QUALITY OF SERVICE PROFILE (REQUESTED)
AT+CGACT ↓	PDP CONTEXT ACTIVATE OR DEACTIVATE
AT+CGDATA ↓	ENTER DATA STATE
AT+CGPADDR ↓	SHOW PDP ADDRESS
AT+CGCLASS ↓	GPRS MOBILE STATION CLASS
AT+CGEREP ↓	CONTROL UNSOLICITED GPRS EVENT REPORTING
AT+CGREG ↓	NETWORK REGISTRATION STATUS
AT+CGSMS ↓	SELECT SERVICE FOR MO SMS MESSAGES
AT+CGCOUNT ↓	GPRS PACKET COUNTERS

MODULE SETUP

step 1 : Insert SIMcard into the SIM slot.

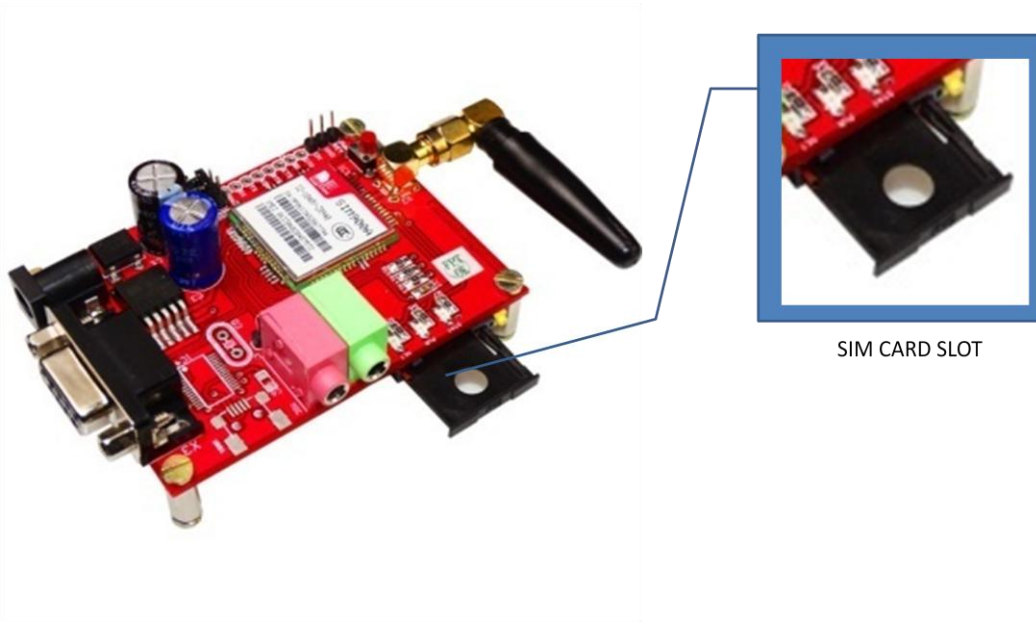

step 2 : Plug in 12V -2A DC power adapter, power led is lit (place jumper between PWRkey and on pin for only to turn ON automatically).

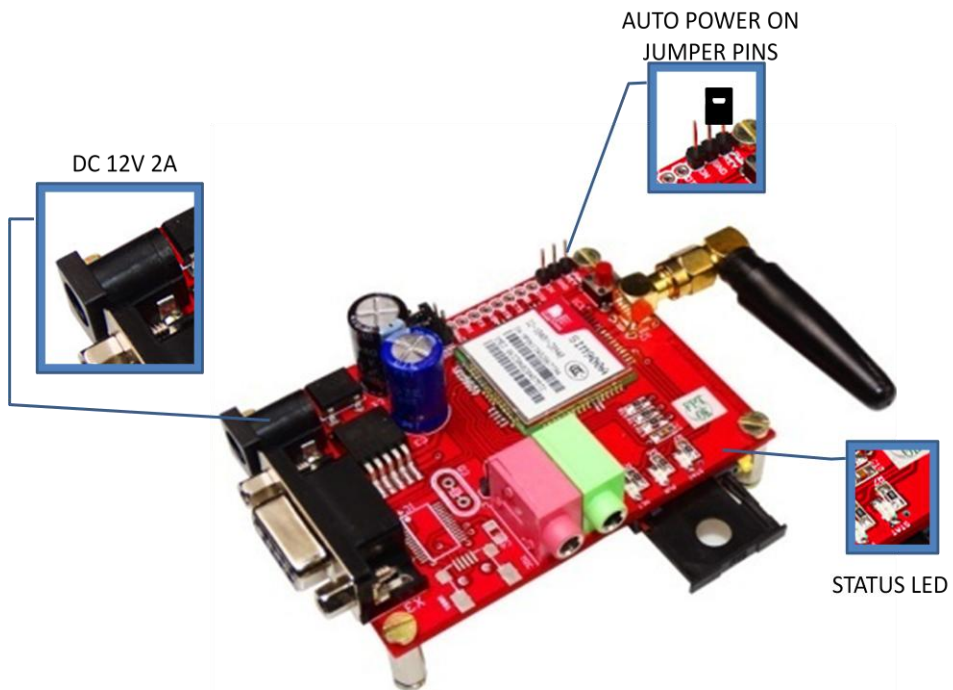

step 3 : Press and hold power button (To turn on manually without jumper)

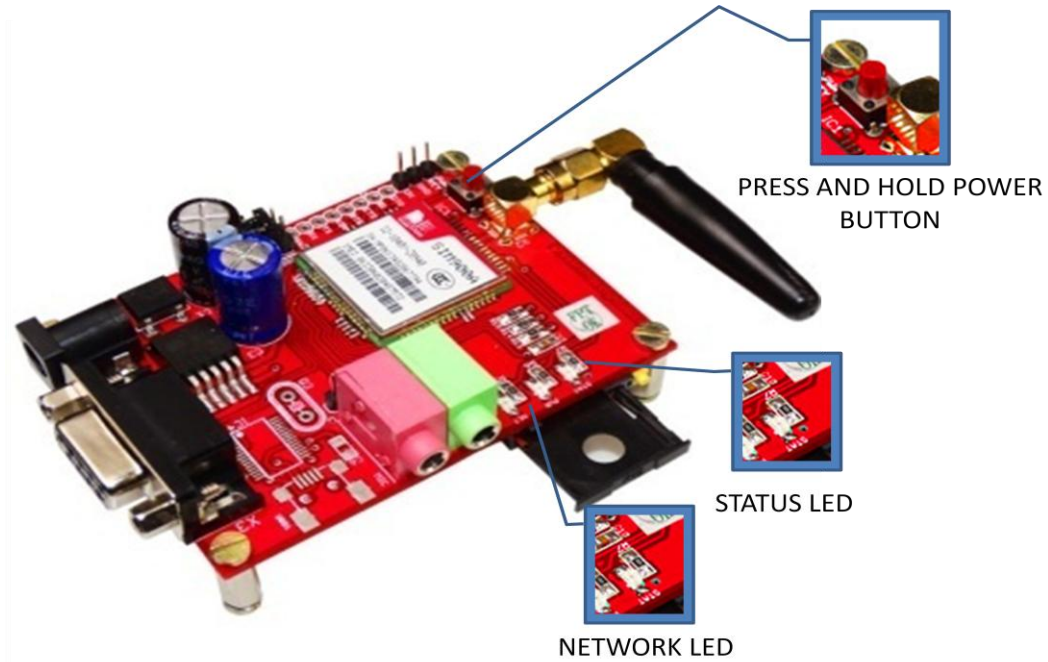

step 4 : Connect to PC through RS232 cable

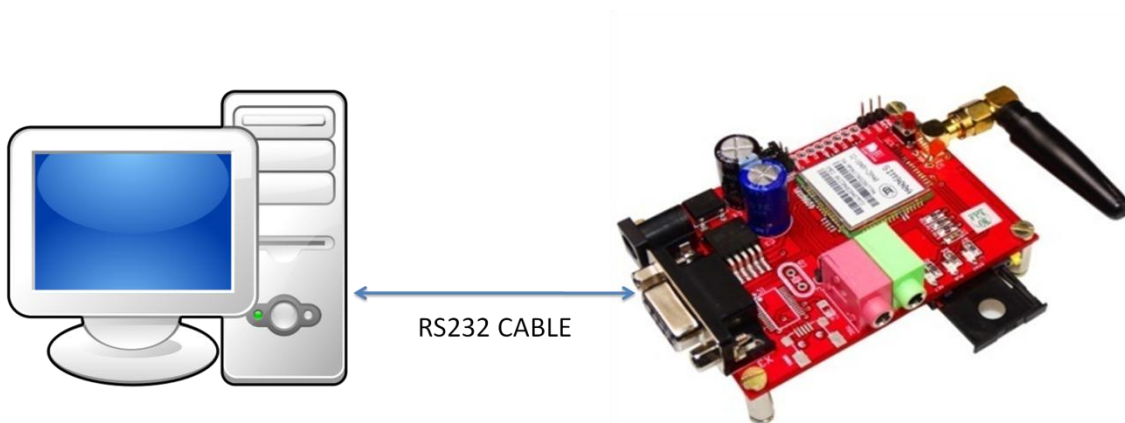

step 5 : open GSM/GPRS utility software ,choose appropriate COM port and use AT commands listed in this manual for basic testing GPRS GSM/messaging and voice calling.

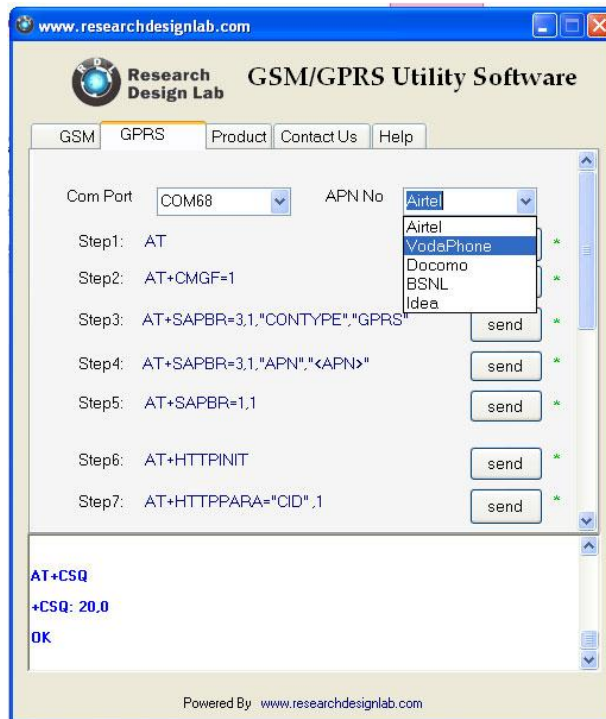
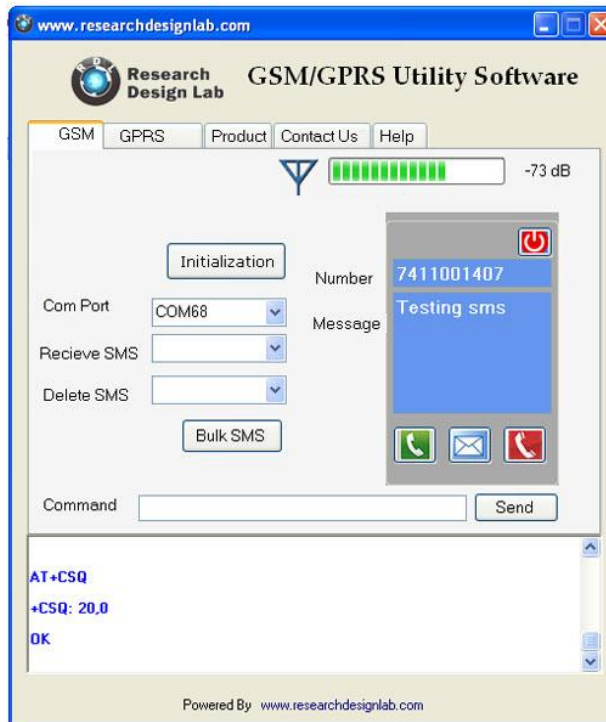

POWER MODES

Power down mode

SIM900A is set power down mode by “AT+CPOWD=0”

There are two methods for the module to enter into low current consumption status

Minimum Functionality Mode

Minimum functionality mode reduces the functionality of the module to a minimum and thus minimizes the current consumption to the lowest level.

If SIM900A has been set to minimum functionality by “AT+CFUN=0”

If SIM900A has been set to full functionality by “AT+CFUN=1”

If SIM900A is set “AT+CFUN=4” to disable both the above functionality.

Sleep mode

We can control SIM900A module to enter or exit the SLEEP mode in customer applications through DTR signal. When DTR is in high level and there is no on air and hardware interrupt (such as GPIO interrupt or data on serial port), SIM900A will enter SLEEP mode automatically. In this mode, SIM900A can still receive paging or SMS from network but the serial port is not accessible.

Wake up SIM900A from sleep mode

- Enable DTR pin to wake up SIM900A. If DTR pin is pulled down to a low level
- This signal will wake up SIM900A from power saving mode. The serial port will be active after DTR changed to low level for about 50ms.
- Receiving a voice or data call from network to wake up SIM900A.
- Receiving a SMS from network to wake up SIM900A.

PINS OF GSM SIM900A Modem

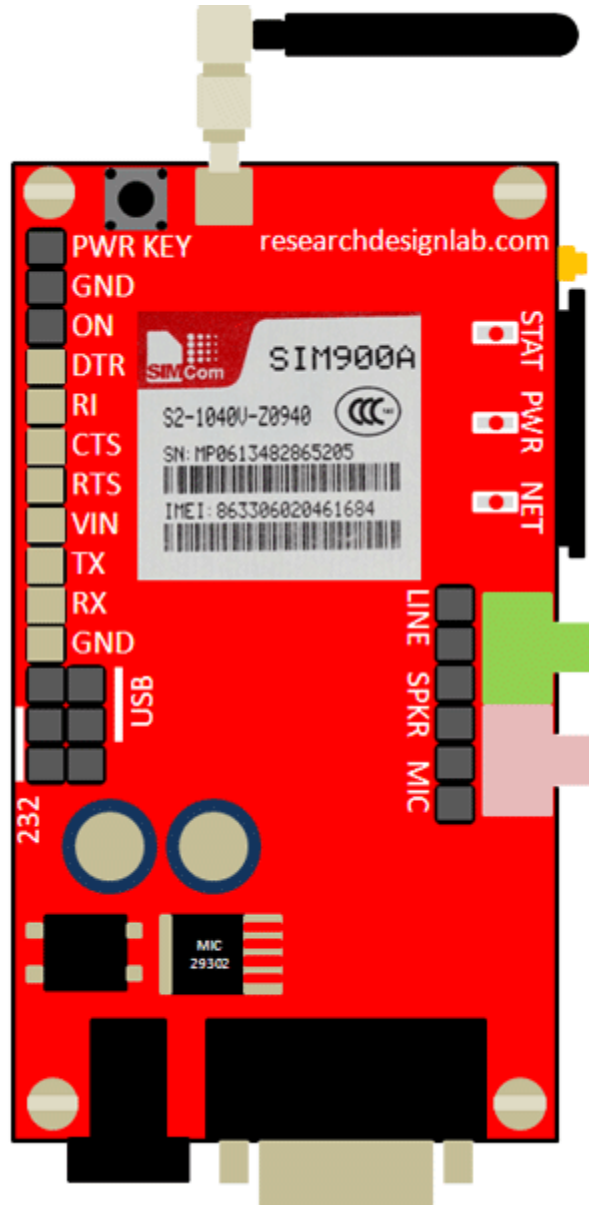

NARATION OF GSM SIM900A MODEM

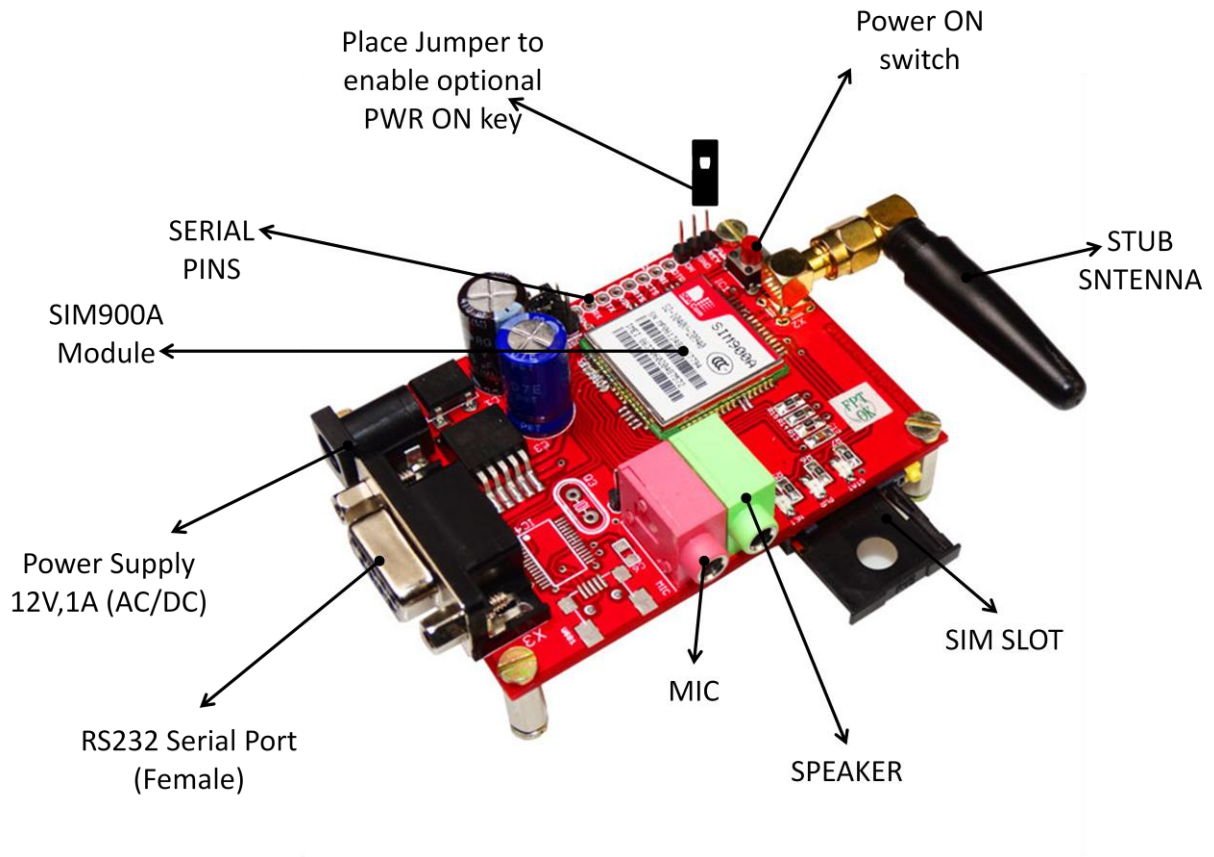

BLOCK DIAGRAMS

INTERFACING UNO AND GSM SHIELD

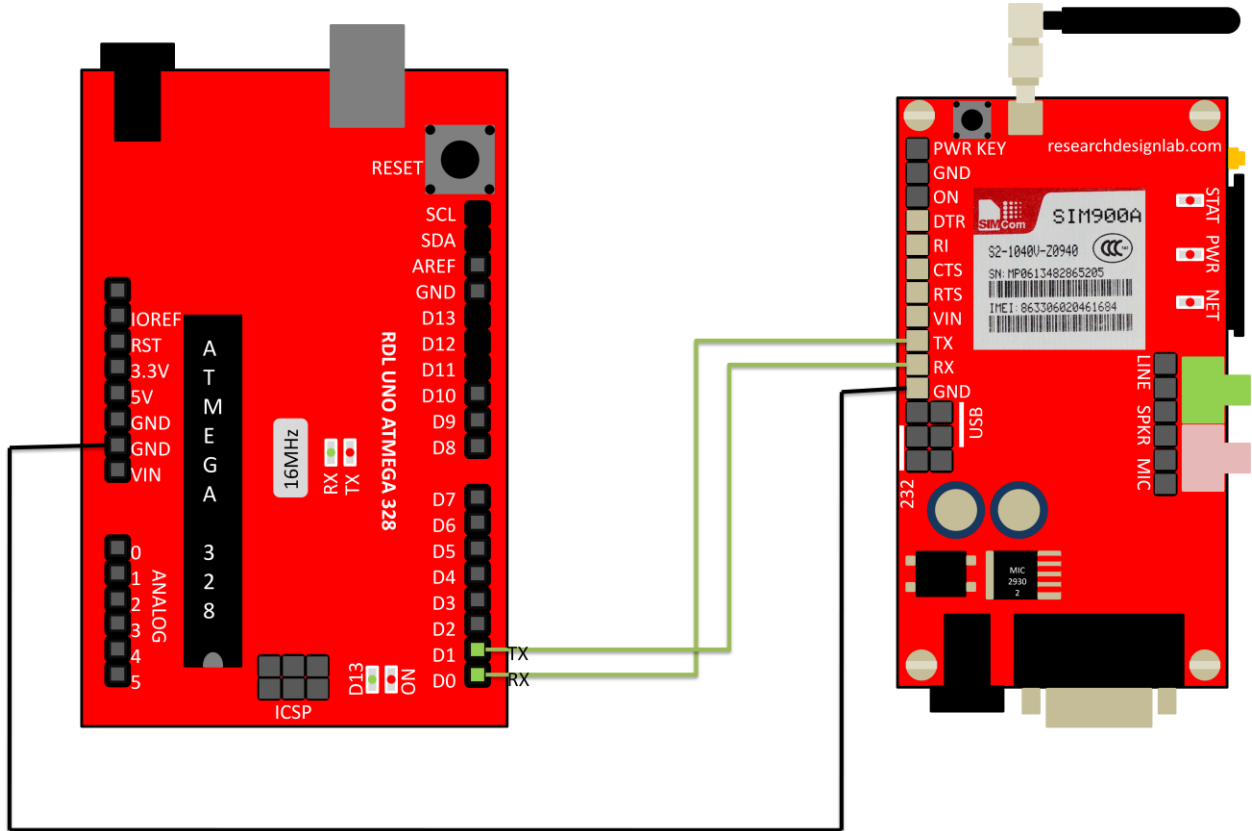

INTERFACING RASPBERRY AND GSM SHIELD

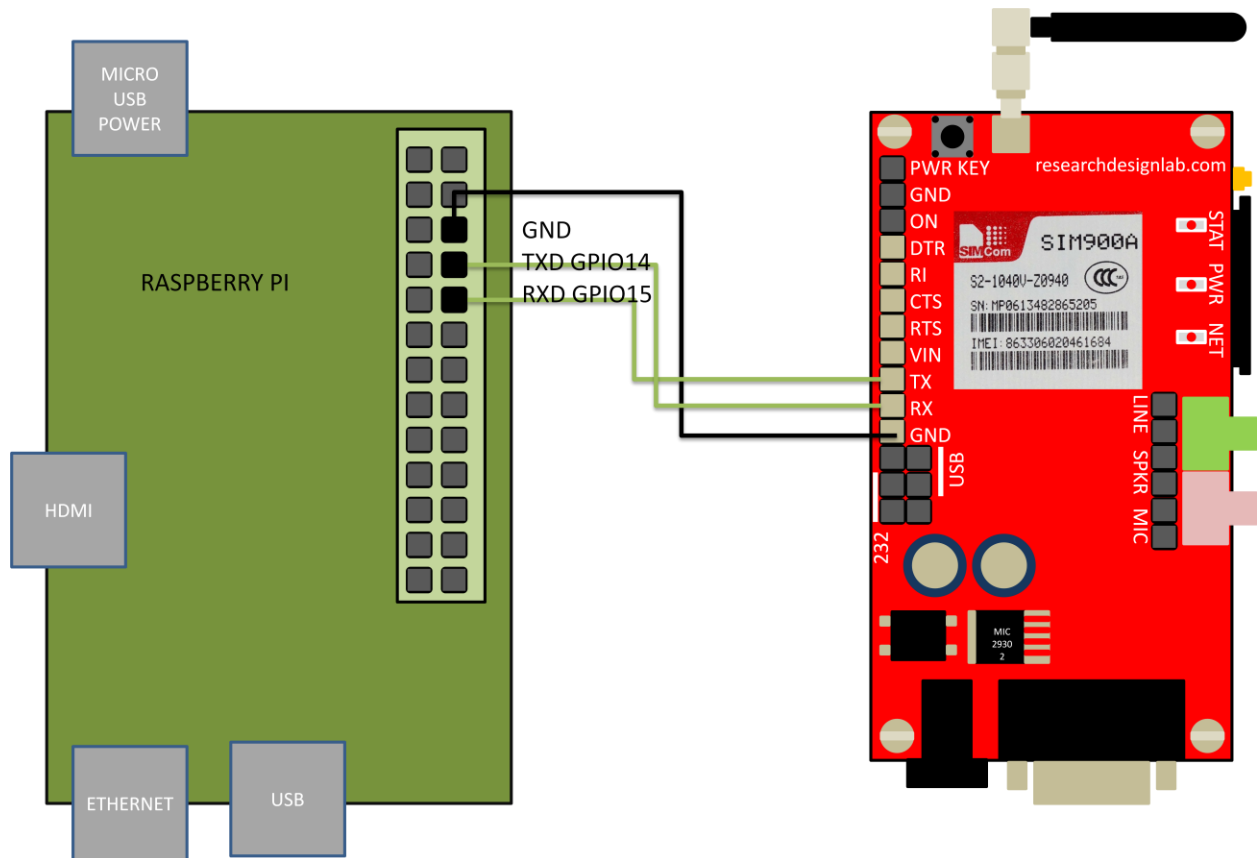

INTERFACING BEAGLEBOARD AND GSM SHIELD

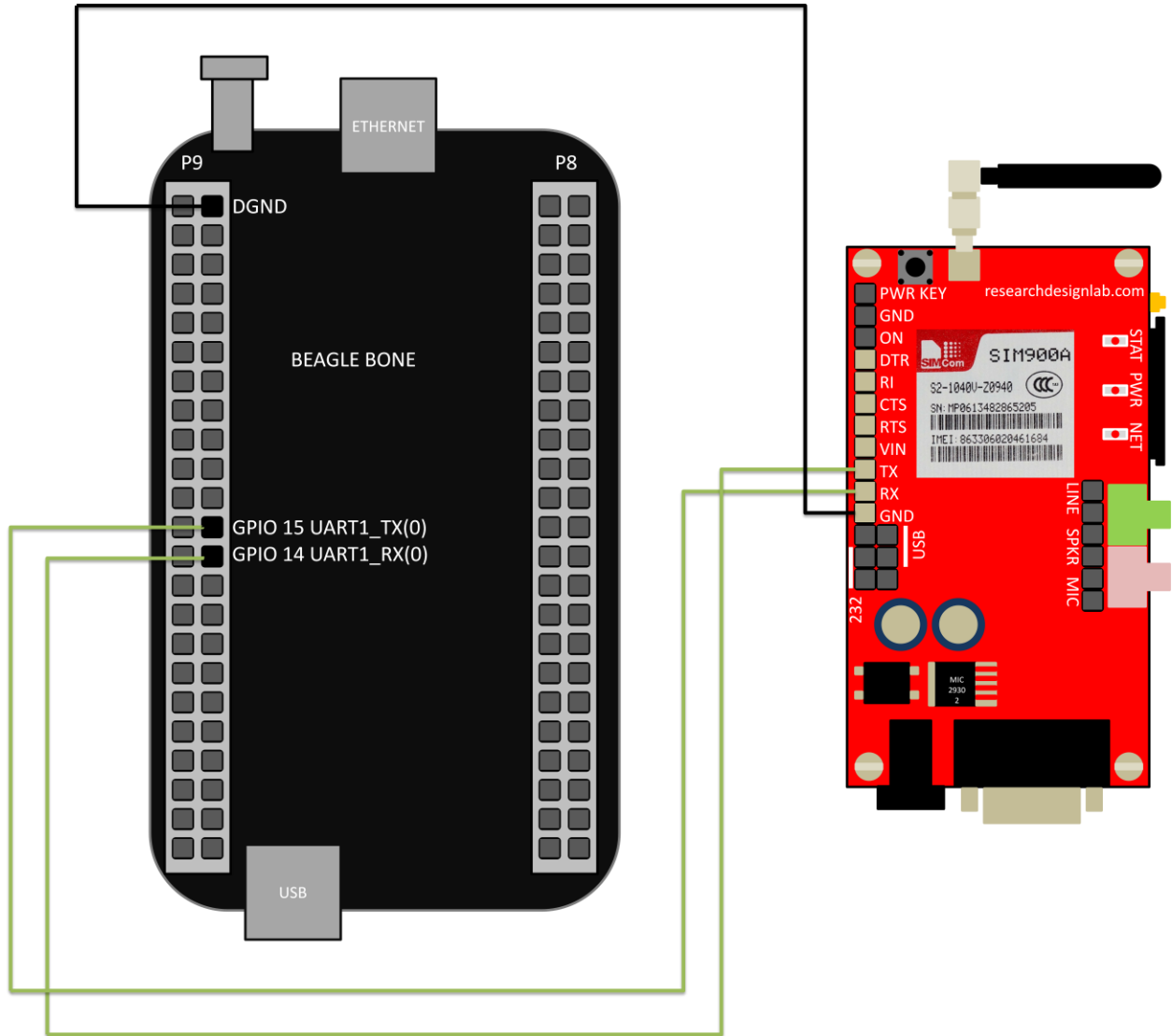

INTERFACING MICROCONTROLLER WITH GSM SHIELD

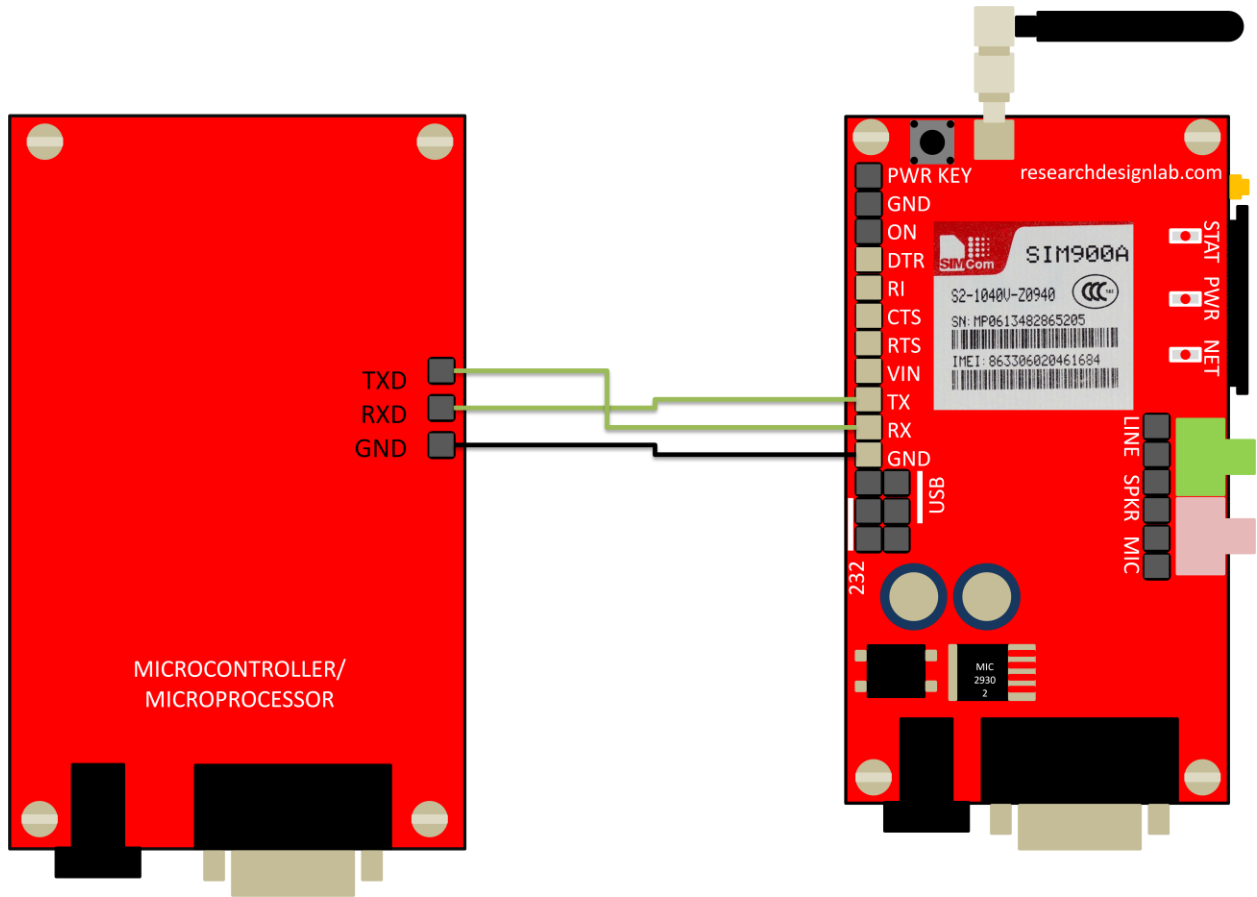

CODES

ARM CODE

<http://researchdesignlab.com/gsm-modem-arm-code>

ATMEL CODE

<http://researchdesignlab.com/gsm-modem-atmel-code>

PIC CODE

<http://forum.researchdesignlab.com/GSM%20SIM900/PIC/SIM900.c>

ARDUNIO CODE

<http://researchdesignlab.com/arduino-gsm2-code>

RASPBERRY PI CODE

SENDING CODE

<http://researchdesignlab.com/gsm-raspberry-code>

RECEIVING CODE

<http://researchdesignlab.com/gsm-raspberry-receiving-code.html>

BEAGLEBONE CODE

SENDING CODE

<http://researchdesignlab.com/gsm-beaglebone-send-code>

RECEIVING CODE

<http://researchdesignlab.com/gsm-beaglebone-receiving-code.html>

MSP430 CODE

<http://forum.researchdesignlab.com/MSP430/MSP/GSM.zip>

GSM POWER SAVING ATMEL CODE

<http://researchdesignlab.com/gsm-power-atmel-code.html>

GSM POWER SAVING PIC CODE

<http://researchdesignlab.com/gsm-power-pic-code.html>

MODULE HANDLING

DO'S AND DONT'S

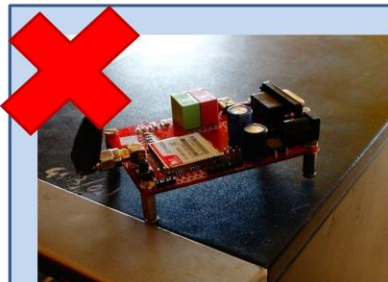

Avoid placing circuit boards on a metal surface

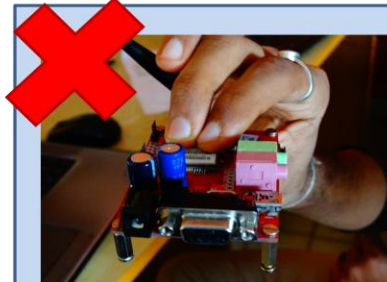

Avoid holding IC when switched ON

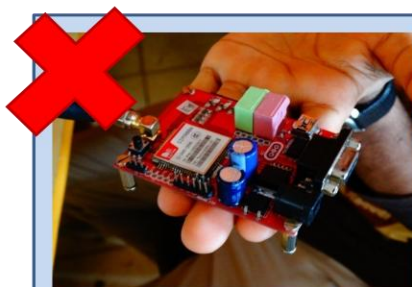

Avoid placing circuit boards on your palm



Avoid holding circuit with component

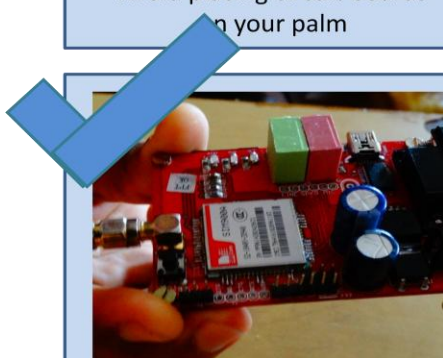

Hold edges while handling the circuit boards

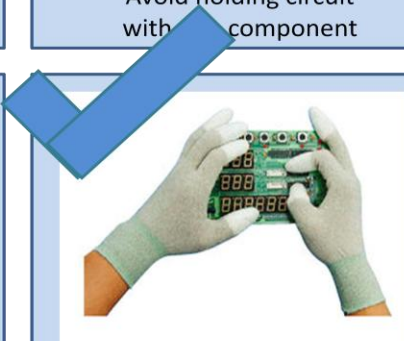

If possible use anti static glove