

MLX91219

High Speed High Accuracy Current Sensor IC with dual OCD

Datasheet



1. Features and Benefits

- End-of-line programmable sensor
- Factory selected 5V or 3.3V supply
- Measurement range from ± 12 to ± 500 mT
- High speed AC and DC current sensing
 - 400kHz bandwidth
 - 2 μ s response time
- High linearity down to $\pm 0.5\%$ full scale
- Low noise
- AEC-Q100 – Grade 0 Automotive Qualification
- Very low thermal drift for wide range
 - Offset drift (<5mV)
 - Sensitivity drift (<1%)
- Fast dual overcurrent detection
 - Internal threshold
 - External threshold (Only SOIC8)
- RoHS compliant



SIP4-VA (MSL-1)

Available

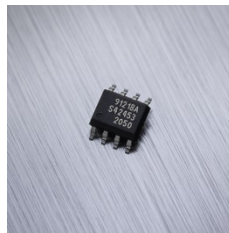

SOIC8 (MSL-3)

Coming soon

2. Application Examples

- High Voltage Traction Motor Inverter
- 48V Boost Recuperation Inverter
- DCDC Converter
- Smart Battery Junction Boxes or BDU
- Smart Fuse Overcurrent Detection
- Battery Management System (BMS)

3. Description

The MLX91219 is a monolithic Hall-effect sensor which is sensitive to the flux density applied orthogonally to the IC surface. The sensor provides an analog output voltage proportional to the applied magnetic flux density.

The transfer characteristic of the MLX91219 is factory trimmed over temperature, and is programmable (offset, sensitivity, filtering, internal overcurrent threshold) during end-of-line customer calibration beyond the default factory trimming by Melexis. With the 400kHz bandwidth and fast response time, it is particularly well suited for high speed applications such as inverters and converters characterized in their fast switching.

In a typical current sensing application, the sensor is used in combination with a ring shaped soft ferromagnetic core. This core is recommended to be laminated for high bandwidth applications. The MLX91219 is placed in a small air gap and the current conductor – a bus bar or a cable – is passed through the inner part of the ferromagnetic ring. On the one hand the ring concentrates and amplifies the magnetic flux seen by the sensor IC, and at the same time it attenuates external magnetic field disturbances.



Figure 1 Typical Current Sensing Application (VA)

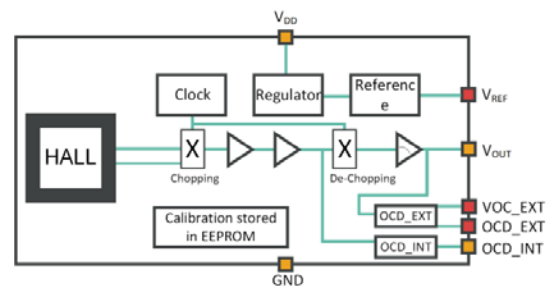

■ SOIC8 only ■ SOIC8 & SIP4-VA

Figure 2 General Block Diagram

Contents

1. Features and Benefits	1
2. Application Examples.....	1
3. Description	1
4. Ordering Information.....	3
5. Functional Diagram.....	4
6. Glossary of Terms	4
7. Pin Definitions and Descriptions	5
1. SOIC-8 Package (coming soon)	5
2. SIP-4 VA Package.....	5
8. Absolute Maximum Ratings	6
9. General Electrical Specification.....	7
10. Magnetic specification.....	7
11. Output accuracy specification	8
12. Timing specification.....	9
13. Overcurrent Detection Specification.....	10
1. General	10
2. Electrical Specification.....	10
3. Internal Overcurrent Detection Principle.....	11
4. External Overcurrent Detection Principle	11
14. Recommended Application Diagram	12
1. SOIC-8 Package	12
2. SIP-4 VA Package	13
15. Standard Information	14
16. ESD Precautions.....	15
17. Packaging information.....	15
1. SOIC-8 -Package Dimensions.....	15
2. SOIC-8 Hall Plate Position.....	16
3. SIP-4 VA Active measurement direction.....	16
18. Disclaimer.....	17

4. Ordering Information

Product	Temperature	Package	Option Code	Packing Form	Supply	Default Sensitivity	Default Offset	Default OCD
MLX91219	L	VA	AAA – 500	BU/CR/CA	5V	7mV/mT	2.5V	128% FS
MLX91219	L	VA	AAA – 501	BU/CR/CA	5V	10mV/mT	2.5V	128% FS
MLX91219	L	VA	AAA – 502	BU/CR/CA	5V	15mV/mT	2.5V	128% FS

Legend:

Temperature Code	L	from -40°C to 150°C ambient temperature
Package Code	VA DC	“VA” for SIP-4 package “DC” for SOIC-8 package – coming soon
Option Code	AAx-5xx	“5” for 5 V supply, ratiometric
	AAx-3xx	“3” for 3.3 V supply, ratiometric
	xxx-x00	Factory trimmed default sensitivity of 7 mV/mT, 2.5V offset and 128%FS OCD
	xxx-x01	Factory trimmed default sensitivity of 10 mV/mT, 2.5V offset and 128%FS OCD
	xxx-x02	Factory trimmed default sensitivity of 15 mV/mT, 2.5V offset and 128%FS OCD
	xxA-xxx xxR-xxx xxS-xxx xxZ-xxx	straight leads 2x 90deg lead bending, 5.34mm height PCB to dambar 2x 90deg lead bending, 3.7mm height PCB to dambar Z-shape, shown to the right
Packing Form	BU CR CA RE	for bulk for Carton reel – Radial taping – available for straight leads only for Carton reel – Ammopack – available for straight leads only for plastic tape on reel – available for selected Trim&Form options only
Ordering Example	“MLX91219LVA-AAZ-501-RE” MLX91219 Conventional Hall current sensor in SIP4 VA package, temperature range -40°C to 150°C, 5V supply, sensitivity of 10mV/mT, 2.5V offset and OCD level of 128%FS delivered with Z-shape leadbending in a plastic tape on reel.	

Melexis is continuously expanding its product portfolio by adding new option codes to better meet the needs of our customer’s applications. For the latest update, please go to Melexis website and download the latest revision of this document. For customization, please contact your local Melexis Sales representative or distributor.

5. Functional Diagram

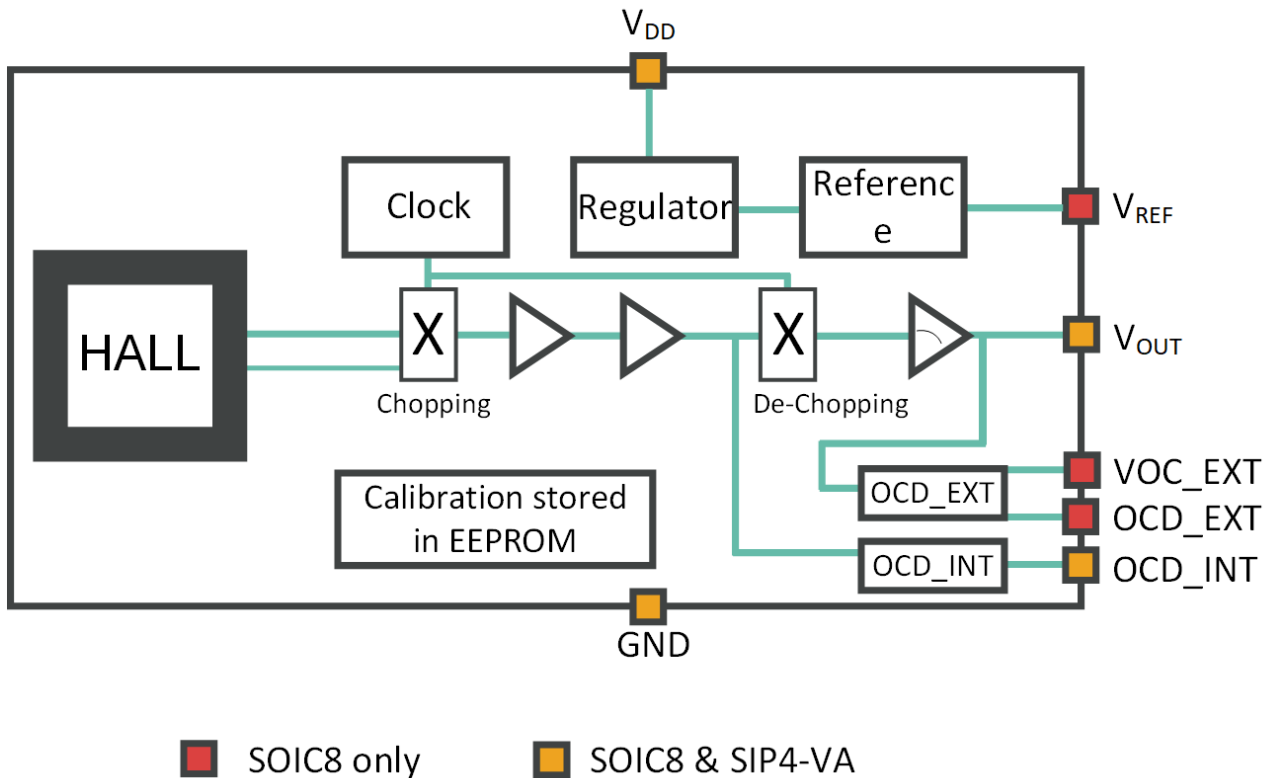

Figure 3 Functional Diagram

6. Glossary of Terms

Terms	Definition
FS	Full Scale, corresponding to 2000mV for a 5V supply, and 1250mV for a 3.3V supply in case of bipolar output. For unipolar outputs these numbers are doubled
T, mT	Tesla and milliTesla, units for the magnetic flux density
NC	Not Connected
PTC	Programming Through the Connector
OCD	OverCurrent Detection
EEPROM	Electrically Erasable Programmable Read-Only Memory
DC	Direct Current
BDU	Battery Disconnect Unit
IC	Integrated Circuit
HTOL	High Temperature Operating Lifetime – ageing test as described in AEC-Q100 standard
TC	Thermal Cycling – stress test as described in AEC-Q100 standard

7. Pin Definitions and Descriptions

1. SOIC-8 Package (coming soon)

Pin #	Name	Type	Description
1	V _{REF}	Analog Input Output	Reference voltage
2	OUT	Analog Output	Output voltage (measurement)
3	GND	Supply	Ground voltage
4	V _{DD}	Supply	Supply voltage
5	NC	-	Not connected
6	OCD _{EXT}	Analog Output	Overcurrent detection based on external threshold
7	OCD _{INT}	Analog Output	Overcurrent detection based on internal threshold
8	VOC _{EXT}	Analog Input	External threshold for the OCD

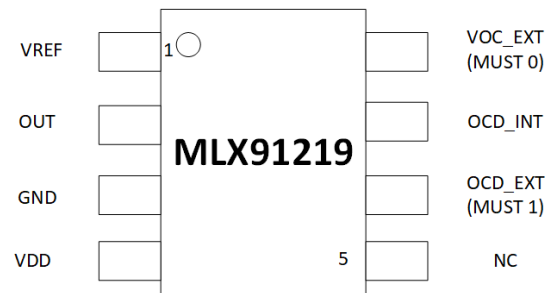

For optimal EMC results, it is recommended to connect the unused (NC) pins to the Ground.

2. SIP-4 VA Package

Pin #	Name	Type	Description
1	V _{DD}	Supply	Supply voltage
2	OUT	Analog Output	Output voltage (measurement)
3	OCD _{INT}	Analog Output	Overcurrent detection based on internal an threshold
4	GND	Supply	Ground voltage

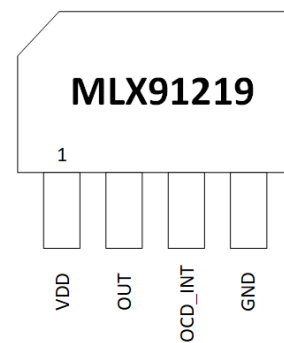

8. Absolute Maximum Ratings

Exceeding the absolute maximum ratings may cause permanent damage. Exposure to absolute maximum-rated conditions for extended periods of time may affect device reliability.

Parameter	Value	Unit
Positive Supply Voltage (overvoltage)	+8	V
Positive Supply Voltage (maintaining application mode)	+6.5	V
Reverse Supply Voltage	-0.3	V
Positive Pin Voltage ⁽¹⁾	$V_{DD} + 0.3$	V
Output Sourcing Current	+25	mA
Reverse Pin Voltage ⁽¹⁾	-0.3	V
Output Sinking Current	50	mA
Maximum Junction Temperature, T_J	165	°C
Operating Ambient Temperature Range, T_A	-40 to +150	°C
Storage Temperature Range, T_S	-55 to +165	°C

(1) Except for V_{DD} and GND

9. General Electrical Specification

Operating Parameters $T_A = -40$ to 150°C and $V_{DD}=5$ V or 3.3 V unless otherwise specified.

Parameter	Symbol	Test Conditions	Min	Typ	Max	Units
Nominal Supply Voltage	V_{DD}	MLX91219LVA-Axx-5xx	4.5	5	5.5	V
		MLX91219LVA-Axx-3xx	3.135	3.3	3.465	V
Supply Current	I_{DD}	Without R_{LOAD} , application mode $V_{DD} = 5\text{V}$ $V_{DD} = 3.3\text{V}$		15.5	19	mA
					15	17
Output Resistance	R_{OUT}	$V_{OUT} = 50\%V_{DD}$, $I_{LOAD} = 10$ mA		1	5	Ω
Voltage Reference Output Resistance	R_{REF}	$V_{REF} = 50\%V_{DD}$, $I_{SINK} = 5$ mA or $I_{SOURCE} = 0.2$ mA <i>For SOIC8 version only</i>	120	200	333	Ω
Output Capacitive Load	C_{LOAD}	Output amplifier stability is optimized for this typical value	0	4.7	6	nF
Output Short Circuit Current	I_{SHORT}	Output shorted to V_{DD} or V_{SS} - Permanent			100	mA
Output Leakage current	I_{LEAK}	High impedance mode, $T_A=150^\circ\text{C}$		2	20	μA
Output Voltage Linear Swing	V_{OUT_LSW}	$V_{DD} > 4.6$ V for Fixed Mode versions	10		90	$\%V_{DD}$

10. Magnetic specification

Operating Parameters $T_A = -40$ to 150°C unless otherwise specified.

Parameter	Symbol	Test Conditions	Min	Typ	Max	Units
Operational Magnetic Field Range	B_{OP}	Full scale output range	12		± 500	mT
Linearity Error	NL	B within B_{OP} , $T_A = 25^\circ\text{C}$			± 0.5	%FS
Programmable Sensitivity	S_{PROG}		4		105	mV/mT
Sensitivity Programming Resolution	S_{RES}			0.5		%

11. Output accuracy specification

Operating Parameters $T_A = -40$ to 150°C , $V_{DD}=5$ V or 3.3 V and for factory calibrated settings unless otherwise specified.

Parameter	Symbol	Test Conditions	Min	Typ	Max	Units
Voltage Reference ⁽¹⁾	V_{REF}	$T_A=25^\circ\text{C}$, Axx-5xx versions		2.5		V
		$T_A=25^\circ\text{C}$, Axx-3xx versions		1.65		V
Thermal Reference Drift ⁽¹⁾	$\Delta^T V_{REF}$	Referred to V_{REF}		<i>tbd</i>		mV
Lifetime Reference Drift ⁽¹⁾	$\Delta^L V_{REF}$			<i>tbd</i>		mV
Voltage Output Quiescent	V_{OQ}	No magnetic field applied, $T_A=25^\circ\text{C}$ Axx-5xx versions, $V_{DD} = 5\text{V}$	2.49	2.5	2.51	V
		Axx-3xx versions, $V_{DD} = 3.3\text{V}$	1.64	1.65	1.66	V
Thermal Offset Drift	$\Delta^T V_{OQ}$	For 5V $T_A= -40$ to 125°C			± 5	mV
		For 5V $T_A=125$ to 150°C			± 8.5	mV
		For 3.3V $T_A= -40$ to 125°C			± 7.5	mV
		For 3.3V $T_A=125$ to 150°C			± 8.5	mV
Lifetime Offset Drift ⁽²⁾	$\Delta^L V_{OQ}$	Compared to level after preconditioning for a given T_A	-2		2	mV
Ratiometry Offset Error	$\Delta^R V_{OQ}$	For 5V, $\pm 10\%$ V_{DD}			± 15	mV
		For 3.3V, $\pm 5\%$ V_{DD}			± 7.5	mV
Absolute Sensitivity	S	$T_A=25^\circ\text{C}$, Axx-500 version		7		mV/mT
		Axx-501 version		10		mV/mT
		Axx-502 version		15		mV/mT
Thermal Sensitivity Drift	$\Delta^T S$	Referred to S, $T_A= -20^\circ\text{C}$ to 125°C			± 1	%
		Referred to S, $T_A= -40^\circ\text{C}$ to 150°C			± 2	%
Lifetime Sensitivity Drift ⁽²⁾	$\Delta^L S$	Compared to level after preconditioning for a given T_A		± 1	± 2	%
Ratiometry Sensitivity Error	$\Delta^R S$	$V_{DD}= 5\text{V} \pm 10\%$, 5xx versions $T_A=25^\circ\text{C}$	-2		+2	%
		$V_{DD}= 3.3\text{V} \pm 5\%$, 3xx versions $T_A=25^\circ\text{C}$	-1		+1	%
Output RMS noise	N_{RMS}	$T_A=25^\circ\text{C}$, SF=1 *-500 version		2.8		mV _{RMS}
		*-501 version		3.4		mV _{RMS}
		*-502 version		4.1		mV _{RMS}

Table 9: Accuracy specifications – analog parameters

(1) Available only with SOIC-8 package, with fixed output (non-ratiometric) only – will be launched soon

(2) Lifetime drift data stems from both 1000h HTOL and 2000 cycles TC as per AEC-Q100

The accuracy specifications are defined for the factory calibrated sensitivity and offset. The achievable accuracy is dependent on the user's end-of-line calibration.

12. Timing specification

Operating Parameters $T_A = -40$ to 150°C , unless otherwise specified.

Parameter	Symbol	Test Conditions	Min	Typ	Max	Units
Step Response Time	T_{RESP}	Delay between the input signal reaching 90% and the output reaching 90% (see Figure 4)			2.1	μs
Bandwidth	BW	f_{-3dB} , $T_A=25^\circ\text{C}$, SF=1 (factory trim)		400		kHz
		f_{-3dB} , $T_A=25^\circ\text{C}$, SF=2 (programmable)		200		kHz
		f_{-3dB} , $T_A=25^\circ\text{C}$, SF=3 (programmable)		100		kHz
Power-on Delay	T_{POD}				1	ms

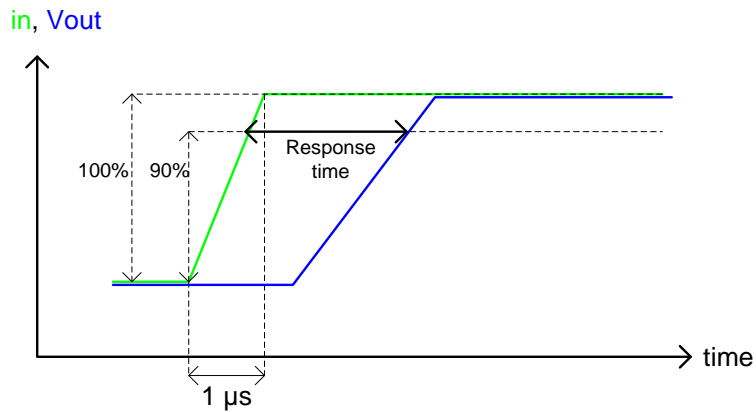

Figure 4 – Response Time definition

13. Overcurrent Detection Specification

1. General

The MLX91219 provides two OCD features that allow detecting overcurrent conditions. In case of OCD events, the OCD_{INT} and OCD_{EXT} open drain output are pulled to ground, generating an active low signal. During normal operation the OCD voltage remains pulled up to V_{DD} with an external pull-up resistor.

The two OCD functions are able to react to an overcurrent event within few microseconds of response time. The overcurrent condition needs a setup time of at least $1\mu s$ to be certain that the event is captured and propagates to the respective OCD pin. After detection by the sensor the output flag will undergo a hold time of $10\mu s$ (effectively latching the OCD event) to make sure that it can be captured by an external microcontroller or system monitoring the OCD pin.

The following table offers a comparison between OCD_{INT} and OCD_{EXT} ; the latter only available on the SOIC8 variant of the MLX91219.

Parameter	OCD_{INT}		OCD_{EXT}
Overcurrent effect	OCD _{INT} pin active low (falling edge)		OCD _{EXT} pin active low (falling edge)
Polarity	Bidirectional OCD		Unidirectional or bidirectional
Availability	SIP4 VA, SOIC8 package		SOIC8 package only
Threshold definition	EEPROM (internal)		Resistive divider on VOC_{EXT}
Threshold range (4bits)	20 .. 200%FS		10 .. 100%FS
Accuracy	~±10%		~±7%
Response time	1.4μs	2.1μs	~10μs
Setup time	~1μs		>10μs
Hold time	7μs	14μs	~10μs

2. Electrical Specification

DC Operating Parameters at $V_{DD} = 5 V$ or $3.3 V$ (unless otherwise specified).

Parameter	Symbol	Test Conditions	Min	Typ	Max	Units
OCD_{INT} output resistance	R_{OCDINT}	1mA sink current	60	90	150	Ω
OCD_{EXT} output resistance	R_{OCDEXT}	1mA sink current	160	190	280	Ω
VOC_{EXT} voltage range	VOC_{EXTR}	$V_{DD} = 5V$, 5xx versions	0.3		2	V
		$V_{DD} = 3.3V$, 3xx versions	0.3		1.2	V

3. Internal Overcurrent Detection Principle

The internal OCD takes fixed threshold voltage values predefined in the EEPROM and do not require any extra components. The OCD_{INT} implementation allows detecting overcurrent outside of the output measurement range of the sensor and is therefore suitable for large current peaks as occurring during short-circuit. If the theoretical sensor output overcomes the OCD_{INT} voltage threshold, the overcurrent event is flagged on OCD_{INT} pin. The default OCD threshold voltages are defined as follow, but other values can be set on request.

Ordering Code	Sensitivity [mV/mT]	OCD_{INT} Factory trimmed Threshold Level [%FS]	OCD_{INT} Factory trimmed Threshold Level [mT]
MLX91219LVA-AAA-500	7	128 %FS	366 mT
MLX91219LVA-AAA-501	10	128 %FS	256 mT
MLX91219LVA-AAA-502	15	128 %FS	170 mT

Table 13: OCD_{INT} threshold currents

4. External Overcurrent Detection Principle

The external OCD uses the voltage applied on VOC_{EXT} pin as threshold voltage. This translates into an overcurrent threshold depending on the sensitivity of the sensor. A voltage divider on VOC_{EXT} allows defining the threshold voltage in a custom way. Depending on the voltage divider configuration, the OCD_{EXT} can be used either in bidirectional or unidirectional mode. The External OCD threshold is defined within the measurement range of the sensor output. It offers a better accuracy than OCD_{INT} but the response is slower. The below table presents the unidirectional and bidirectional external OCD configurations. Please refer to section 14 for more details about the application diagram and the recommended resistances.

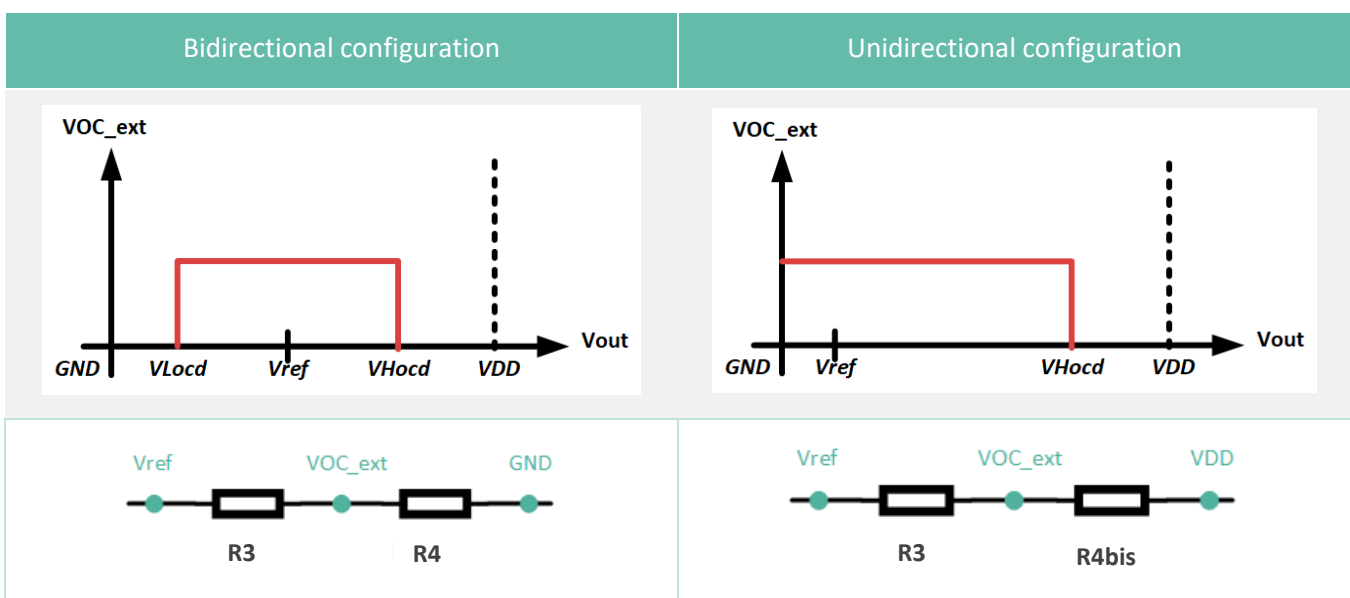

$$VOC_{EXT} = V_{REF} * \frac{R_3}{R_3 + R_4}$$

$$VLocd = VOC_{EXT}$$

$$VHocd = 2 * V_{REF} - VLocd$$

$$VOC_{EXT} = V_{REF} + (V_{DD} - V_{REF}) * \frac{R_3}{R_3 + R_{4bis}}$$

$$VHocd = VOC_{EXT}$$

14. Recommended Application Diagram

1. SOIC-8 Package

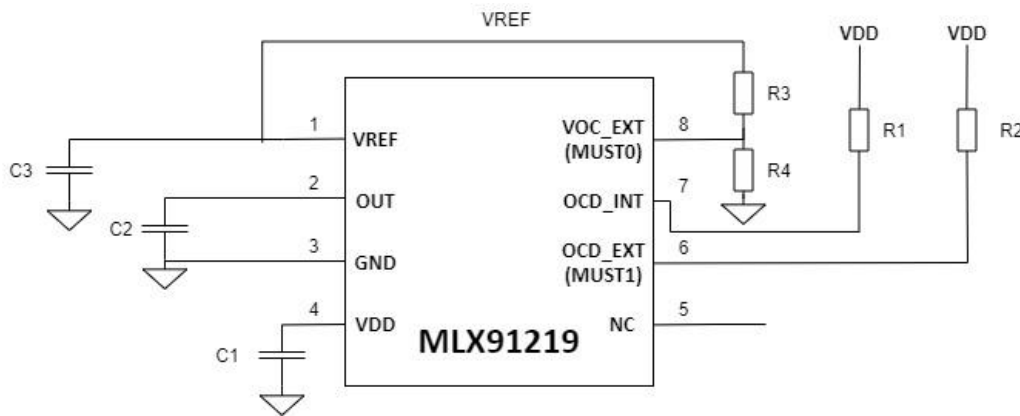

Part	Description	Value	Unit
C1	Supply capacitor, EMI, ESD	47	nF
C2	Decoupling, EMI, ESD	4.7	nF
C3	Decoupling, EMI, ESD	47	nF
R1	Internal OCD resistor	10	kΩ
R2	External OCD resistor	10	kΩ
R3/R4/R4bis	Uni-/Bidirectional OCD customized ratio	-	kΩ

2. SIP-4 VA Package

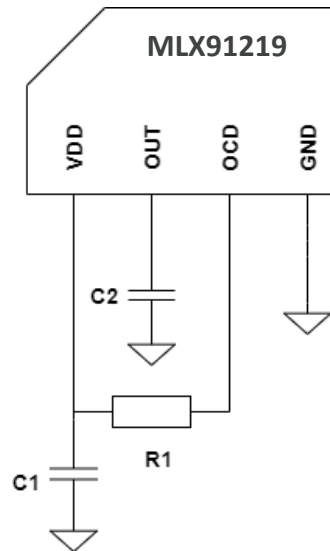

Part	Description	Value	Unit
C1	Supply capacitor, EMI, ESD	47	nF
C2	Decoupling, EMI, ESD	4.7	nF
R1	Internal OCD resistor	10	kΩ

15. Standard Information

Our products are classified and qualified regarding soldering technology, solderability and moisture sensitivity level according to following test methods:

Reflow Soldering SMD's (Surface Mount Devices)

- IPC/JEDEC J-STD-020
Moisture/Reflow Sensitivity Classification for Nonhermetic Solid State Surface Mount Devices (classification reflow profiles according to table 5-2)
- EIA/JEDEC JESD22-A113
Preconditioning of Nonhermetic Surface Mount Devices Prior to Reliability Testing (reflow profiles according to table 2)

Wave Soldering SMD's (Surface Mount Devices) and THD's (Through Hole Devices)

- EN60749-20
Resistance of plastic- encapsulated SMD's to combined effect of moisture and soldering heat
- EIA/JEDEC JESD22-B106 and EN60749-15
Resistance to soldering temperature for through-hole mounted devices

Iron Soldering THD's (Through Hole Devices)

- EN60749-15
Resistance to soldering temperature for through-hole mounted devices

Solderability SMD's (Surface Mount Devices) and THD's (Through Hole Devices)

- EIA/JEDEC JESD22-B102 and EN60749-21
Solderability

For all soldering technologies deviating from above mentioned standard conditions (regarding peak temperature, temperature gradient, temperature profile etc) additional classification and qualification tests have to be agreed upon with Melexis. The application of Wave Soldering for SMD's is allowed only after consulting Melexis regarding assurance of adhesive strength between device and board.

Melexis recommends reviewing on our web site the General Guidelines soldering recommendation (<https://www.melexis.com/en/quality-environment/soldering>).

Melexis is contributing to global environmental conservation by promoting **lead free** solutions. For more information on qualifications of **RoHS** compliant products (RoHS = European directive on the Restriction Of the use of certain Hazardous Substances) please visit the quality page on our website (<https://www.melexis.com/en/quality-environment>).

16. ESD Precautions

Electronic semiconductor products are sensitive to Electro Static Discharge (ESD). Always observe Electro Static Discharge control procedures whenever handling semiconductor products.

17. Packaging information

1. SOIC-8 -Package Dimensions

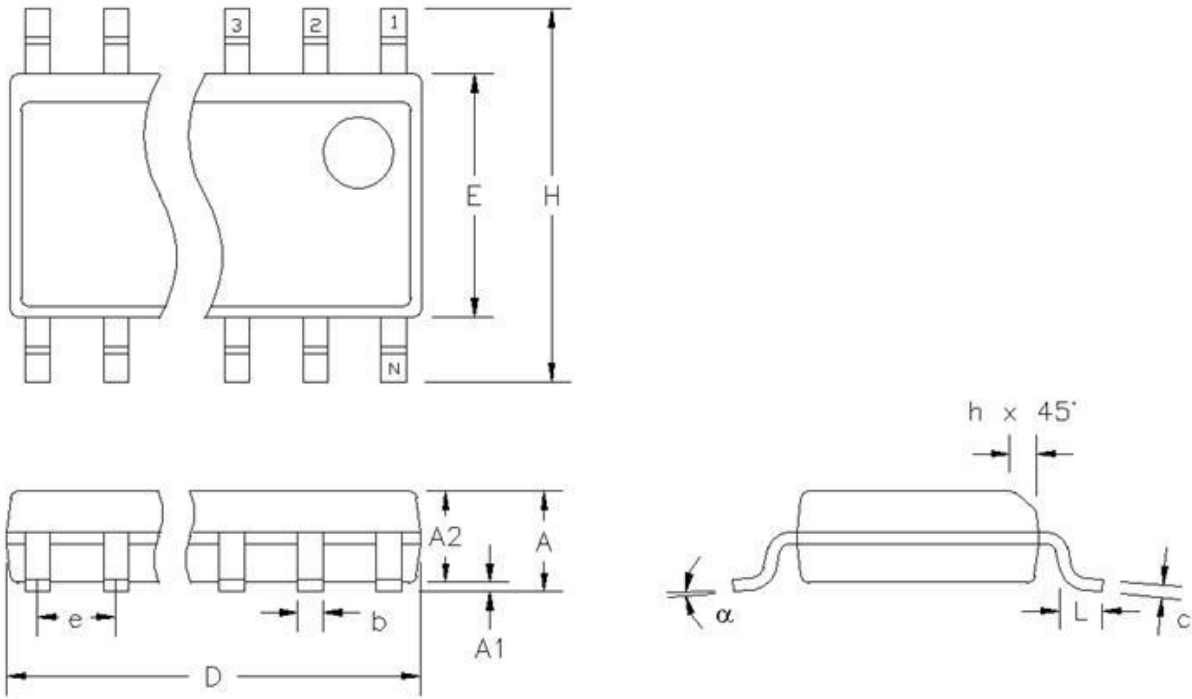

Figure 7 : SOIC8 Package Dimensions [inches]

[mm]	A	A1	A2	D	E	H	L	b	c	e	h	α
min	1.52	0.10	1.37	4.80	3.81	5.80	0.41	0.35	0.19	1.27	0.25	0°
max	1.73	0.25	1.57	4.98	3.99	6.20	1.27	0.49	0.25	BSC	0.50	8°

[inch]	A	A1	A2	D	E	H	L	b	c	e	h	α
min	.060	.004	.054	.189	.150	.228	.016	.014	.008	.050	.010	0°
max	.068	.010	.062	.196	.157	.244	.050	.019	.010	BSC	.020	8°

2. SOIC-8 Hall Plate Position

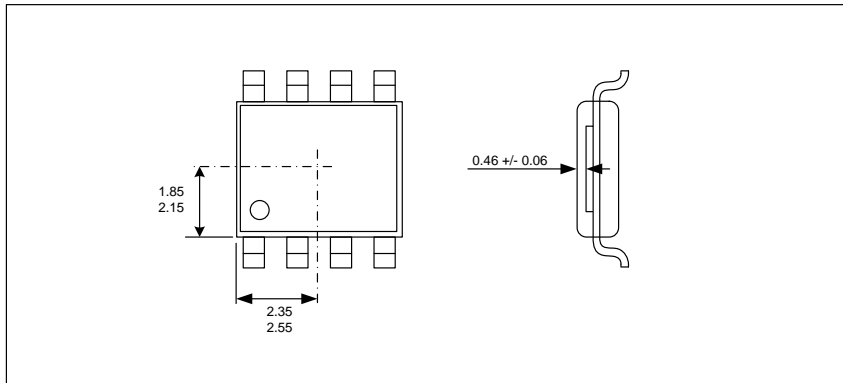

Figure 8: Hall plate position

3. SIP-4 VA Active measurement direction

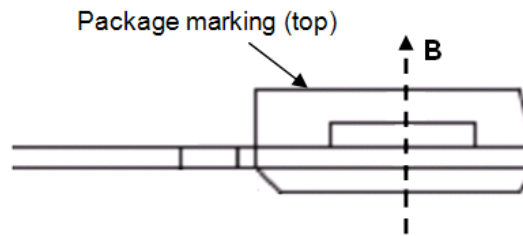

Figure 9: VA/SIP 4L Package. Sensor's active measurement direction

18. Disclaimer

The content of this document is believed to be correct and accurate. However, the content of this document is furnished "as is" for informational use only and no representation, nor warranty is provided by Melexis about its accuracy, nor about the results of its implementation. Melexis assumes no responsibility or liability for any errors or inaccuracies that may appear in this document. Customer will follow the practices contained in this document under its sole responsibility. This documentation is in fact provided without warranty, term, or condition of any kind, either implied or expressed, including but not limited to warranties of merchantability, satisfactory quality, non-infringement, and fitness for purpose. Melexis, its employees and agents and its affiliates' and their employees and agents will not be responsible for any loss, however arising, from the use of, or reliance on this document. Notwithstanding the foregoing, contractual obligations expressly undertaken in writing by Melexis prevail over this disclaimer.

This document is subject to change without notice, and should not be construed as a commitment by Melexis. Therefore, before placing orders or prior to designing the product into a system, users or any third party should obtain the latest version of the relevant information. Users or any third party must determine the suitability of the product described in this document for its application, including the level of reliability required and determine whether it is fit for a particular purpose.

This document as well as the product here described may be subject to export control regulations. Be aware that export might require a prior authorization from competent authorities. The product is not designed, authorized or warranted to be suitable in applications requiring extended temperature range and/or unusual environmental requirements. High reliability applications, such as medical life-support or life-sustaining equipment or avionics application are specifically excluded by Melexis. The product may not be used for the following applications subject to export control regulations: the development, production, processing, operation, maintenance, storage, recognition or proliferation of:

- 1. chemical, biological or nuclear weapons, or for the development, production, maintenance or storage of missiles for such weapons;*
- 2. civil firearms, including spare parts or ammunition for such arms;*
- 3. defense related products, or other material for military use or for law enforcement;*
- 4. any applications that, alone or in combination with other goods, substances or organisms could cause serious harm to persons or goods and that can be used as a means of violence in an armed conflict or any similar violent situation.*

No license nor any other right or interest is granted to any of Melexis' or third party's intellectual property rights.

If this document is marked "restricted" or with similar words, or if in any case the content of this document is to be reasonably understood as being confidential, the recipient of this document shall not communicate, nor disclose to any third party, any part of the document without Melexis' express written consent. The recipient shall take all necessary measures to apply and preserve the confidential character of the document. In particular, the recipient shall (i) hold document in confidence with at least the same degree of care by which it maintains the confidentiality of its own proprietary and confidential information, but no less than reasonable care; (ii) restrict the disclosure of the document solely to its employees for the purpose for which this document was received, on a strictly need to know basis and providing that such persons to whom the document is disclosed are bound by confidentiality terms substantially similar to those in this disclaimer; (iii) use the document only in connection with the purpose for which this document was received, and reproduce document only to the extent necessary for such purposes; (iv) not use the document for commercial purposes or to the detriment of Melexis or its customers. The confidentiality obligations set forth in this disclaimer will have indefinite duration and in any case they will be effective for no less than 10 years from the receipt of this document.

This disclaimer will be governed by and construed in accordance with Belgian law and any disputes relating to this disclaimer will be subject to the exclusive jurisdiction of the courts of Brussels, Belgium.

The invalidity or ineffectiveness of any of the provisions of this disclaimer does not affect the validity or effectiveness of the other provisions.

The previous versions of this document are repealed.

Melexis © - No part of this document may be reproduced without the prior written consent of Melexis. (2021)

IATF 16949 and ISO 14001 Certified

***For the latest version of this document or find your local contact, visit us at
www.melexis.com***