

TMCM-1617-GRIP-REF HW & TMCL FW Manual

Hardware Version V1.00 | Document Revision V1.01 • 2021-May-07

The TMCM-1617-GRIP-REF is an open source hardware reference design for the TMCM-1617 BLDC servo drive. To be used in robotic gripper applications, the board is designed in a standard gripper electronics form-factor. It is able to control a BLDC motor via EtherCAT®, IO-Link® or Trinamic’s RS-485 based TMCL protocol. In addition, the board features configurable analog output and input channels as well as configurable digital output and input channels using Maxim Integrated MAX22000 and MAX14906 industrial IO solutions.

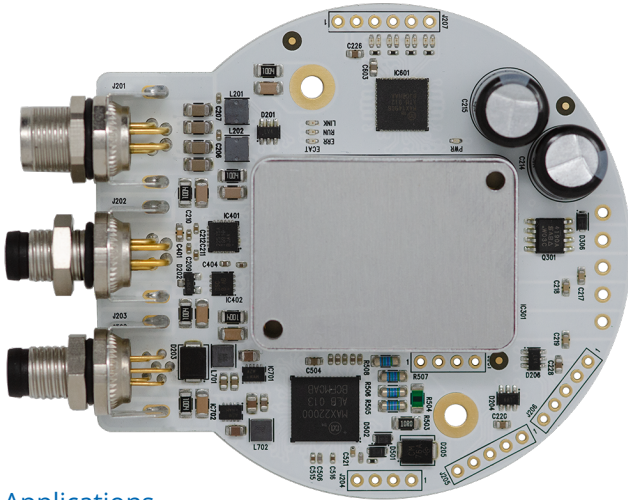

Applications

- Robotic Grippers

Features

- Single axis BLDC servo driver for up to 2.5 A RMS motor current
- +24 V Nominal Supply Voltage (+20 V to +28 V)
- Digital Hall sensor interface
- ABN encoder interface
- 4 Digital +24 V I/O (highside switch, push-pull driver, or a Type 1 and 3, or Type 2 digital input)
- 1 Analog output (± 12.5 V output voltage range, or ± 25 mA or ± 2.5 mA output current range)
- 1 Differential analog input (± 15 V, ± 2.5 V, ± 500 mV, ± 250 mV, and ± 125 mV input voltage ranges)

Simplified Block Diagram

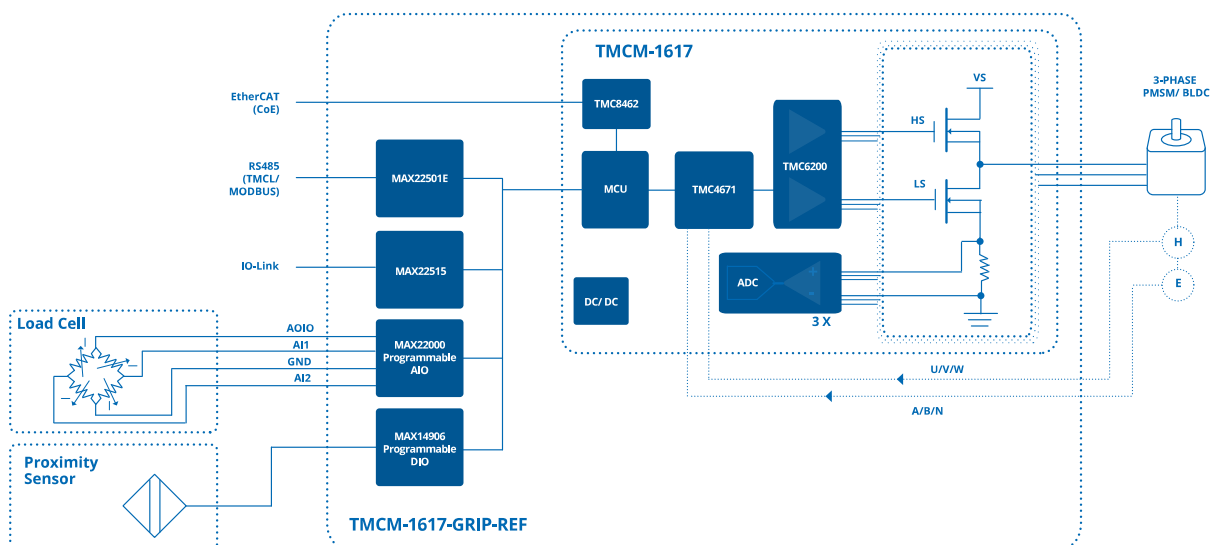

©2021 TRINAMIC Motion Control GmbH & Co. KG, Hamburg, Germany
 Terms of delivery and rights to technical change reserved.
 Download newest version at: www.trinamic.com



Read entire documentation.

Contents

1	Order Code	4
2	Featured Parts	5
3	Mechanical Information	6
3.1	Module Size	6
3.2	Mounting a Heat Sink	7
4	Connectors and LEDs	8
4.1	EtherCAT® Connector and LEDs	9
4.2	IO-Link Connector	9
4.3	Supply And RS485 Connector and PWR LED	10
4.4	Motor Connector	10
4.5	Brake Output Connector	10
4.6	Hall Sensor Connector	11
4.7	Encoder Connector	11
4.8	Analog I/O Connector	11
4.9	Digital I/O Connector and LEDs	13
4.10	Programming Connector	13
5	Operational Ratings and Characteristics	14
5.1	Absolute Maximum Ratings	14
5.2	Electrical Characteristics (Ambient Temperature 25° C)	14
6	First Steps with the TMCL-IDE	17
6.1	Getting Started with the TMCL-IDE	17
6.2	Using the TMCL Direct Mode	18
6.3	Wizard	18
7	TMCL Details	19
7.1	Binary Command Format	19
7.1.1	Checksum Calculation	19
7.2	Reply Format	20
7.2.1	Status Codes	20
7.3	TMCL Command Overview	22
7.4	TMCL Commands by Subject	22
7.4.1	Motion Commands	22
7.4.2	Parameter Commands	23
7.5	Detailed TMCL Command Descriptions	24
7.5.1	ROR (Rotate Right)	24
7.5.2	ROL (Rotate Left)	25
7.5.3	MST (Motor Stop)	26
7.5.4	MVP (Move to Position)	27
7.5.5	SAP (Set Axis Parameter)	29
7.5.6	GAP (Get Axis Parameter)	30
7.5.7	STAP (Store Axis Parameter)	31
7.5.8	RSAP (Restore Axis Parameter)	32
7.5.9	STGP (Store Global Parameter)	33
7.5.10	RSGP (Restore Global Parameter)	34
7.5.11	TMCL Control Commands	35
8	TMCM-1617-GRIP-REF Features over the TMCM-1617 standard TMCL Firmware	35
8.1	Digital IOs	36



8.2 Analog output	36
8.3 Analog input	37
9 Axis Parameters	39
10 Global Parameters	47
10.1 Bank 0	47
11 Figures Index	49
12 Tables Index	50
13 Supplemental Directives	51
13.1 Producer Information	51
13.2 Copyright	51
13.3 Trademark Designations and Symbols	51
13.4 Target User	51
13.5 Disclaimer: Life Support Systems	51
13.6 Disclaimer: Intended Use	51
13.7 Collateral Documents & Tools	52
14 Revision History	53
14.1 Hardware Revision	53
14.2 Firmware Revision	53
14.3 Document Revision	53



1 Order Code

Order Code	Description
TMCM-1617-GRIP-REF	Robotic Gripper Reference Design.

Table 1: Order code



2 Featured Parts

- TMCM-1617 - Low weight, miniaturized single axis servo drive for 3-phase BLDC motors
- MAX22000 - Industrial Software Configurable Analog I/O
- MAX14906 - Quad-Channel Industrial Digital Output, Digital Input
- MAX22515 - IO-Link Transceiver with Integrated Protection
- MAX17552 - 60V, 100mA, Ultra-Small, High-Efficiency, Synchronous Step-Down DC-DC Converter
- MAX22501 - 100Mbps Half-Duplex RS-485/RS-422 Transceivers



3 Mechanical Information

3.1 Module Size

The TMCM-1617-GRIP-REF is designed in a standard gripper electronics form-factor. The module has 2 mounting holes for M3 screws.

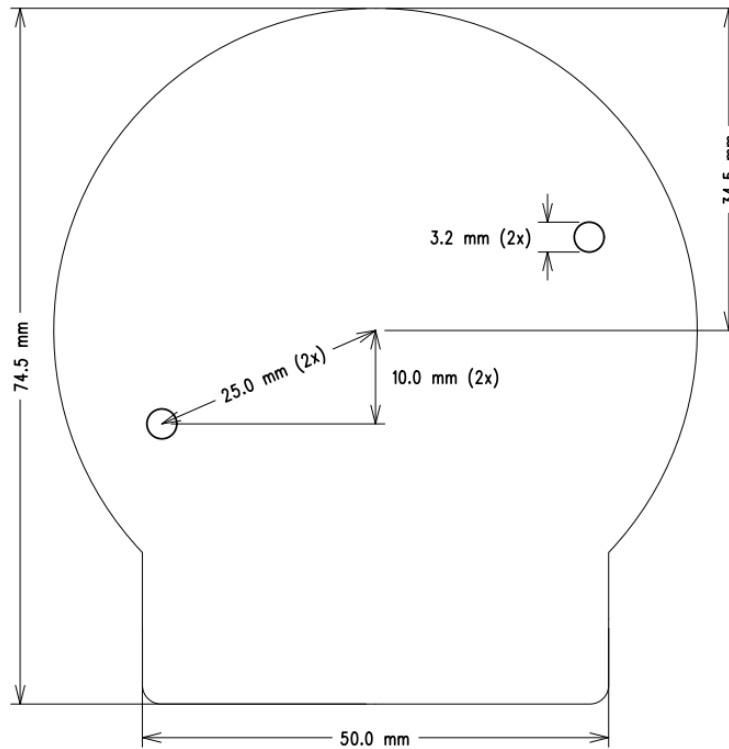

Figure 1: TMCM-1617-GRIP-REF dimensions



3.2 Mounting a Heat Sink

The aluminum housing of TMCM-1617 has 2 mounting holes for M2.5 screws/bolts that allow mounting a heat sink. A thermal gap pad (electrically isolating) is recommended between the housing and the heat sink for proper heat transfer.

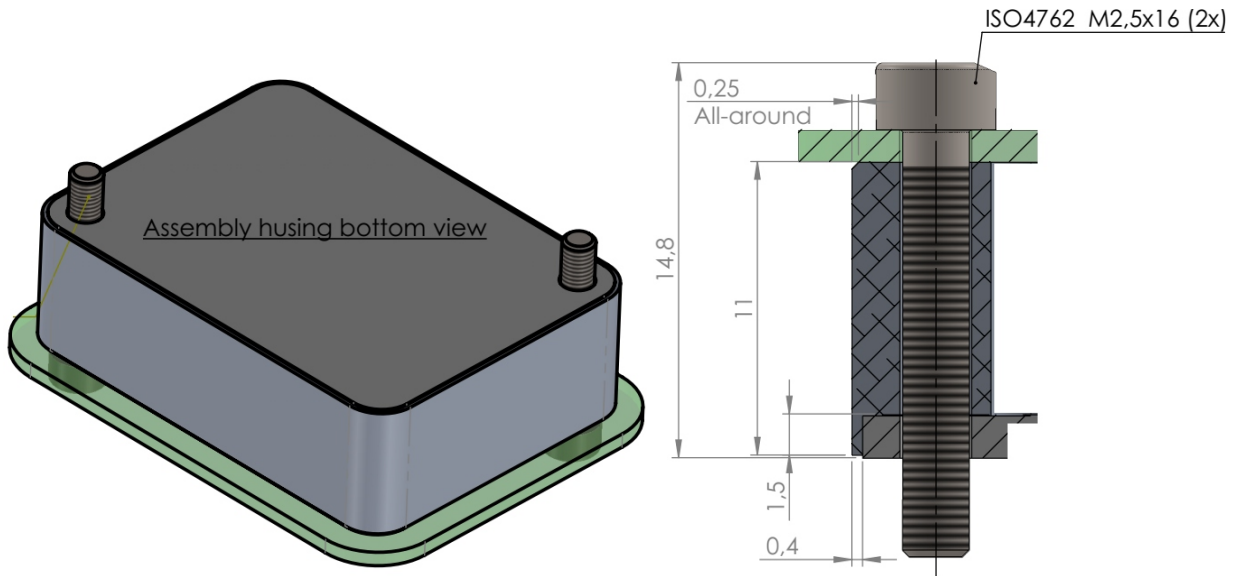

Figure 2: Heat sink mounting



4 Connectors and LEDs

The TMCM-1617-GRIP-REF comes with 3 connectors:

- EtherCAT® (in)
- IO-Link
- Supply and RS485

The connectors for other interfaces are not mounted to allow the user to choose between mounting standard 2.54/3.81 mm headers or connecting wires directly to the board:

- Motor
- Brake output
- Hall sensor
- Encoder
- Analog I/O
- Digital I/O
- Programming

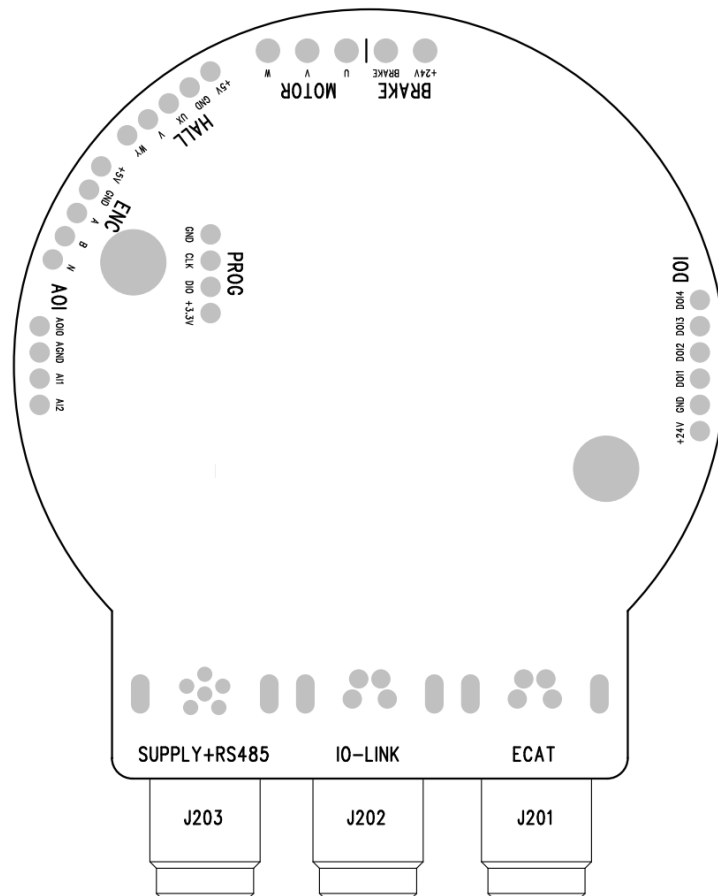
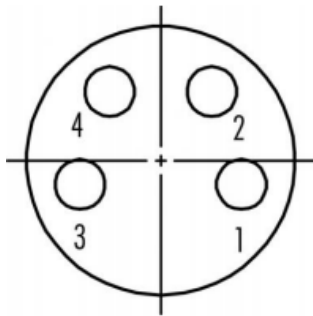

Figure 3: TMCM-1617-GRIP-REF connectors (bottom view)



4.1 EtherCAT® Connector and LEDs

Connector: 4-pin female M8 (Binder 86 6618 1121 00004).



Pin	Signal	Description
1	TP	Transmit line (non-inverting)
2	RP	Receive line (non-inverting)
3	RN	Receive line (inverting)
4	TN	Transmit line (inverting)

Figure 4: EtherCAT® connector (J201)

The EtherCAT® interface includes 3 status LEDs.

Label	Description
RUN	EtherCAT® status LED, green
ERR	EtherCAT® error LED, red
IN	EtherCAT® in LED, green

Table 2: EtherCAT® LEDs (D303-D305)

4.2 IO-Link Connector

Connector: 4-pin male M8 (Binder 86 6319 1121 00004).

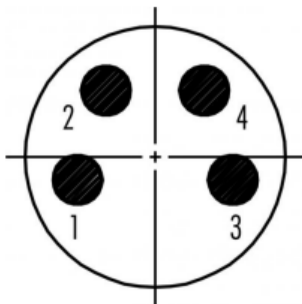

Pin	Signal	Description
1	V24	Supply input
2	DI	Auxiliary digital input
3	GND	Supply and signal ground
4	C/Q	IO-Link transceiver input/output

Figure 5: IO-Link connector (J202)



4.3 Supply And RS485 Connector and PWR LED

Connector: 6-pin male M8 (Binder 86 6319 1121 00006).

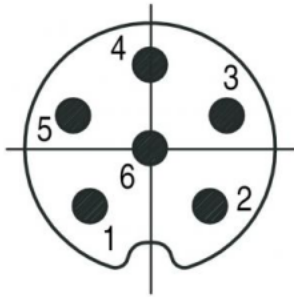

Pin	Signal	Description
1	RS485 B	RS485 interface (inverting)
2	RS485 A	RS485 interface (non-inverting)
3	+24V	Supply input
4	+24V	Supply input
5	GND	Supply ground
6	GND	Supply ground

Figure 6: Supply and RS485 connector (J203)

There is a blue status LED on the board indicating that the board is powered.

4.4 Motor Connector

Connector: 3-pin 3.81 mm standard header.

Connector	Signal	Description
1	U	Motor phase U
2	V	Motor phase V
3	W	Motor phase W

Table 3: Motor connector (PTH203-PTH205)

4.5 Brake Output Connector

Connector: 2-pin 3.81 mm standard header.

Connector	Signal	Description
1	+24V	Supply output
2	Brake	PWM controlled low-side output

Table 4: Brake output connector (PTH206-PTH207)



4.6 Hall Sensor Connector

Connector: 5-pin 2.54mm standard header.

Pin	Signal	Description
1	+5V	Supply output for external sensor
2	GND	Signal and supply ground
3	U	Digital Hall sensor input, U channel, internal 4.7k Ω pull-up to +5V
4	V	Digital Hall sensor input, V channel, internal 4.7k Ω pull-up to +5V
5	W	Digital Hall sensor input, W channel, internal 4.7k Ω pull-up to +5V

Table 5: Hall sensor connector (J206)

4.7 Encoder Connector

Connector: 5-pin 2.54mm standard header.

Pin	Signal	Description
1	+5V	Supply output for external sensor
2	GND	Signal and supply ground
3	A	Digital quadrature/incremental encoder, A channel, internal 4.7k Ω pull-up to +5V
4	B	Digital quadrature/incremental encoder, B channel, internal 4.7k Ω pull-up to +5V
5	N	Digital quadrature/incremental encoder, N channel, internal 4.7k Ω pull-up to +5V

Table 6: ABN Encoder connector (J205)

4.8 Analog I/O Connector

Connector: 4-pin 2.54mm standard header.

Pin	Signal	Description
1	AOI0	Analog input/output
2	AGND	Analog ground
3	AI1	Analog input
4	AI2	Analog input

Table 7: Analog I/O connector (J204)

The table below describes the different I/O modes and available connections.



Mode	Connection
Analog Output Voltage Mode (AOVM)	AOI0 to AGND
Analog Output Current Mode (AOCM)	AOI0 to AGND
Analog Input Voltage Mode (AIVM)	AOI0, AI1 or AI2 to GND for single-ended AI1 to AI2 for differential
Analog Input Current Mode (AICM)	AI1 to AI2

Table 8: Analog I/O modes



4.9 Digital I/O Connector and LEDs

Connector: 6-pin 2.54mm standard header.

Pin	Signal	Description
1	+24V	Supply output
2	GND	Signal and supply ground
3	DOI1	Digital input/output
4	DOI2	Digital input/output
5	DOI3	Digital input/output
6	DOI4	Digital input/output

Table 9: Digital I/O connector (J207)

The digital I/O interface includes 8 status LEDs (1 green status LED and 1 red error LED per channel).

4.10 Programming Connector

Connector: 4-pin 2.54mm standard header.

Pin	Signal	Description
1	+3.3V	Supply output
2	SWDIO	SWD data input/output
3	SWCLK	SWD clock input
4	GND	Signal and supply ground

Table 10: Programming connector (J301)



5 Operational Ratings and Characteristics

5.1 Absolute Maximum Ratings

Parameter	Min	Max	Unit
Supply voltage		+28	V
Motor phase current RMS		2.5	A
Ambient temperature	-30	+60	°C
Max load on +5V supply outputs		100	mA
Max load on +3.3V supply output		50	mA

Table 11: Absolute Maximum Ratings

NOTICE

Never Exceed the absolute maximum ratings! Stresses above those listed under "Absolute Maximum Ratings" may cause permanent damage to the device. This is a stress rating only and functional operation of the device at those or any other conditions above those indicated in the operation listings of this specification is not implied. Exposure to maximum rating conditions for extended periods may affect device reliability.

5.2 Electrical Characteristics (Ambient Temperature 25° C)

The basic electrical characteristics of the IO-Link interface are given in the table below. For complete information refer to Maxim Integrated MAX22515 IO-Link transceiver datasheet.

Parameter	Symbol	Min	Typ	Max	Unit
Supply voltage	V_{24}	8	24	36	V
C/Q and DI input voltage range	V_{IN}	$V_{V24} - 36$		36	V
C/Q and DI input threshold high	V_{TH}	10.8		12.5	V
C/Q and DI input threshold low	V_{TL}	8.8		10.5	V
C/Q and DI input hysteresis	V_{HYS}		2		V
C/Q driver current limit	I_{CL}	210	240	270	mA

Table 12: IO-Link Electrical Characteristics

The basic electrical characteristics of the RS485 interface are given in the table below. For complete information refer to Maxim Integrated MAX22501E RS485 transceiver datasheet.

Parameter	Symbol	Min	Typ	Max	Unit
Driver common-mode output voltage	V_{OC}		2.5	3	V



Driver differential output voltage	V_{OD}	1.5			V
Receiver common-mode voltage range	V_{CM}	-15		15	V
Receiver differential input threshold high	V_{TH_H}	50		200	mV
Receiver differential input threshold low	V_{TH_L}	-200		-50	mV
Receiver differential input hysteresis	V_{HYS}		250		mV

Table 13: RS485 Electrical Characteristics

Parameter	Symbol	Min	Typ	Max	Unit
Input threshold high	V_{TH}		1.9		V
Input threshold low	V_{TL}		1.1		V
Input hysteresis	V_{HYS}		0.8		V
Input bandwidth	f_U		34		kHz

Table 14: Hall Sensor Electrical Characteristics

Parameter	Symbol	Min	Typ	Max	Unit
Input threshold high	V_{TH}		1.9		V
Input threshold low	V_{TL}		1.1		V
Input hysteresis	V_{HYS}		0.8		V
Input bandwidth	f_U		3.4		MHz

Table 15: Encoder Electrical Characteristics

The basic electrical characteristics of the analog I/O interface are given in the table below. For complete information refer to Maxim Integrated MAX22200 datasheet.

Parameter	Symbol	Min	Typ	Max	Unit
Input voltage range	V_{IN}		±12.5		V
Input voltage linear range	V_{IN}	-10.5		10.5	V
Output current range	I_{OUT}		±25		mA
Output current linear range	I_{OUT}	-21		21	mA

Table 16: Analog I/O Electrical Characteristics

The basic electrical characteristics of the digital I/O interface are given in the table below. For complete information refer to Maxim Integrated MAX14906 datasheet.



Parameter	Symbol	Min	Typ	Max	Unit
Input threshold high	V_{TH}	6.7		8.0	V
Input hysteresis	V_{HYS}		1.2		V
Output high-side on-resistance	R_{ON_HS}		120	240	m Ω
Output low-side on-resistance	R_{ON_LS}		1	3	Ω

Table 17: Digital I/O Electrical Characteristics



6 First Steps with the TMCL-IDE

In this chapter you can find some hints for your first steps with the TMCM-1617-GRIP-REF and TMCL. The TMCL-IDE can be very helpful to get familiar with the TMCM-1617-GRIP-REF.

Things that you will need

- Your TMCM-1617-GRIP-REF module.
- An USB to RS485 converter.
- A power supply (24V DC) for your TMCM-1617-GRIP-REF module.
- The TMCL-IDE 3.x already installed on your PC.
- A BLDC motor with Hall sensors or an ABN Encoder.

6.1 Getting Started with the TMCL-IDE

Once you have the RS485 connection ready and opened up the TMCL-IDE you need to connect the the device. Therefor click on the COM-port that belongs to your USB to RS485 converter, and connect using 115200 baud.

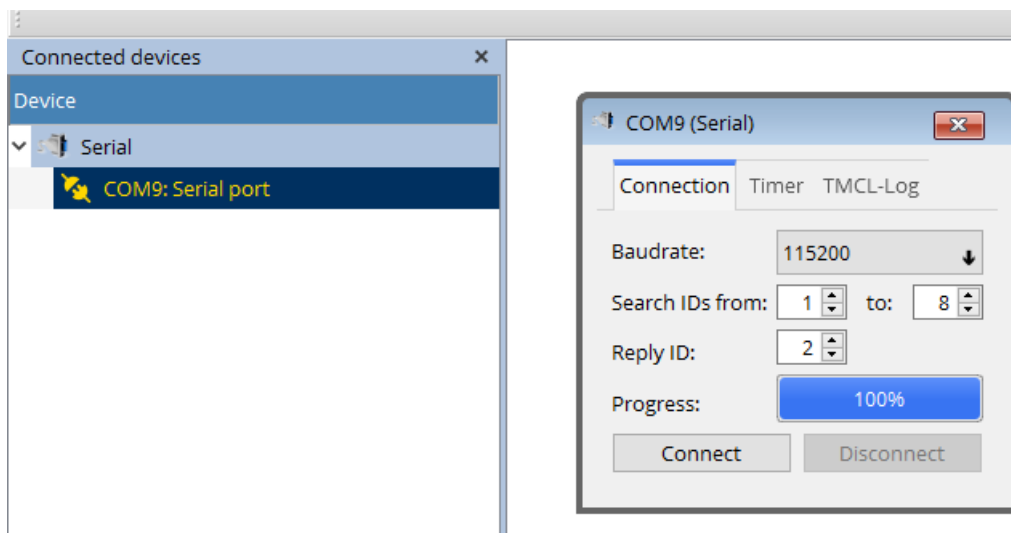

Now the TMCM-1617-GRIP-REF should show up in the tree view.

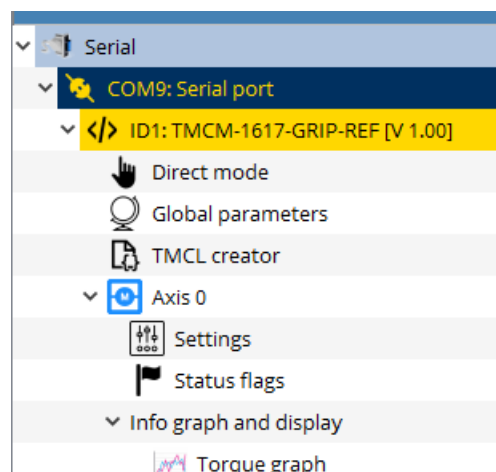

6.2 Using the TMCL Direct Mode

At first try to use some TMCL commands in direct mode. In the TMCL-IDE a tree view showing the TMCM-1617-GRIP-REF and all tools available for it is displayed. Click on the Direct Mode entry of the tool tree. Now, the Direct Mode tool will pop up.

With the Direct Mode tool you can choose a TMCL command, enter the necessary parameters and execute the command.

6.3 Wizard

The TMCL-IDE wizard is a big help to find the right parameters for the motor, Hall sensor and encoder settings. To start the wizard click the wizard symbol on the top right of the TMCL-IDE.

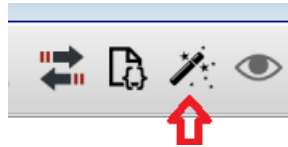

7 TMCL Details

As with most TRINAMIC modules the software running on the microprocessor of the TMCM-1617-GRIP-REF consists of two parts, a boot loader and the firmware itself. Whereas the boot loader is installed during production and testing at TRINAMIC and remains untouched throughout the whole lifetime, the firmware can be updated by the user. New versions can be downloaded free of charge from the TRINAMIC website (<http://www.trinamic.com>).

In direct mode the TMCL communication over RS485 follows a strict master/slave relationship, in which a host device (e.g. PC/PLC/MCU) is acting as the interface bus master and will send a command to the TMCM-1617-GRIP-REF. The TMCL interpreter on the module will then interpret this command, do the initialization of the motion controller, read inputs and write outputs or whatever is necessary according to the specified command. As soon as this step has been done, the module will send a reply back over the interface to the bus master. Only then should the master transfer the next command.

Normally, the module will just switch to transmission and occupy the bus for a reply, otherwise it will stay in receive mode. It will not send any data over the interface without receiving a command first. This way, any collision on the bus will be avoided when there are more than two nodes connected to a single bus. Every command has a binary representation and a mnemonic. The binary format is used to send commands from the host to a module in direct mode, whereas the mnemonic format is used for easy usage of the commands when developing standalone TMCL applications using the TMCL-IDE (IDE means Integrated Development Environment).

There is also a set of configuration variables for the axis and for global parameters which allow individual configuration of nearly every function of a module. This manual gives a detailed description of all TMCL commands and their usage.

7.1 Binary Command Format

Every command consists of a one-byte command field, a one-byte type field, a one-byte motor/bank field and a four-byte value field. To address a device on the RS485 bus the command has to be enclosed by an address byte at the beginning and a checksum byte at the end. So the RS485 frame consists of nine bytes. And looks as follows

TMCL Command Format	
Bytes	Meaning
1	Module address
1	Command number
1	Type number
1	Motor or Bank number
4	Value (MSB first!)
1	Checksum

Table 18: TMCL Command Format

7.1.1 Checksum Calculation

As mentioned above, the checksum is calculated by adding up all bytes (including the module address byte) using 8-bit addition. Here is an example on how to calculate the checksum in C:



```

1 unsigned char i, Checksum;
  unsigned char Command[9];
3
  // set the bytes of Command array to the desired command
5 ..
7 Checksum = Command[0];
  for(i = 1; i < 8; i++)
9 {
    Checksum += Command[i];
11 }
  // insert the checksum as last byte of the command
13 Command[8] = Checksum;
15 // Now, the command is ready to be send the TMCM-1617-GRIP-REF

```

7.2 Reply Format

Every time a command has been sent to a module, the module sends a reply. The reply looks as follows:

TMCL Reply Format	
Bytes	Meaning
1	Reply address
1	Module address
1	Status (e.g. 100 means no error)
1	Command number
4	Value (MSB first!)
1	Checksum

Table 19: TMCL Reply Format

The checksum is again calculated by adding up all the other bytes using an 8-bit addition. Do not send the next command before having received the reply!

7.2.1 Status Codes

The reply contains a status code, which has one of the following values:



TMCL Status Codes	
Code	Meaning
100	Successfully executed, no error
1	Wrong checksum
2	Invalid command
3	Wrong type
4	Invalid value
5	Configuration EEPROM locked
6	Command not available

Table 20: TMCL Status Codes



7.3 TMCL Command Overview

This section gives a short overview of all TMCL commands.

Overview of all TMCL Commands			
Command	Number	Parameter	Description
ROR	1	<motor number>, <velocity>	Rotate right with specified velocity
ROL	2	<motor number>, <velocity>	Rotate left with specified velocity
MST	3	<motor number>	Stop motor movement
MVP	4	ABS REL, <motor number>, <position offset>	Move to position (absolute or relative)
SAP	5	<parameter>, <motor number>, <value>	Set axis parameter (motion control specific settings)
GAP	6	<parameter>, <motor number>	Get axis parameter (read out motion control specific settings)
STAP	7	<parameter>, <motor number>, <value>	Store axis parameter (store motion control specific settings)
RSAP	8	<parameter>, <motor number>	Restore axis parameter (restore motion control specific settings)
STGP	11	<parameter>, <bank number>	Store global parameter (TMCL user variables only)
RSGP	12	<parameter>, <bank number>	Restore global parameter (TMCL user variables only)

Table 21: Overview of all TMCL Commands

7.4 TMCL Commands by Subject

7.4.1 Motion Commands

These commands control the motion of the motor. They are the most important commands and can be used in direct mode or in standalone mode.

Motion Commands		
Mnemonic	Command number	Meaning
ROL	2	Rotate left
ROR	1	Rotate right
MVP	4	Move to position
MST	3	Motor stop

Table 22: Motion Commands



7.4.2 Parameter Commands

These commands are used to set, read and store axis parameters or global parameters. Axis parameters can be set independently for each axis, whereas global parameters control the behavior of the module itself. These commands can also be used in direct mode and in standalone mode.

Parameter Commands		
Mnemonic	Command number	Meaning
SAP	5	Set axis parameter
GAP	6	Get axis parameter
STAP	7	Store axis parameter
RSAP	8	Restore axis parameter
STGP	11	Store global parameter
RSGP	12	Restore global parameter

Table 23: Parameter Commands



7.5 Detailed TMCL Command Descriptions

The module specific commands are explained in more detail on the following pages. They are listed according to their command number.

7.5.1 ROR (Rotate Right)

The motor is instructed to rotate with a specified velocity in right direction (increasing the position counter). The velocity is given in rpm.

Internal function:

- First, velocity mode is selected.
- Then, the velocity value is transferred to axis parameter #40 (target velocity).

Related commands: ROL, MST, SAP, GAP.

Binary Representation			
Instruction	Type	Motor/Bank	Value
1	0	0	-2147483648...2147583647

Reply in Direct Mode	
Status	Value
100 - OK	don't care

Example

Rotate right motor 0, velocity 500.

Binary Form of ROR 0, 51200	
Field	Value
Target address	01 _h
Instruction number	01 _h
Type	00 _h
Motor/Bank	00 _h
Value (Byte 3)	00 _h
Value (Byte 2)	00 _h
Value (Byte 1)	C8 _h
Value (Byte 0)	00 _h
Checksum	CA _h



7.5.2 ROL (Rotate Left)

The motor is instructed to rotate with a specified velocity in left direction (decreasing the position counter). The velocity is given in rpm.

Internal function:

- First, velocity mode is selected.
- Then, the velocity value is transferred to axis parameter #40 (target velocity).

Related commands: ROR, MST, SAP, GAP.

Binary Representation			
Instruction	Type	Motor/Bank	Value
2	0	0	-2147483648...2147583647

Reply in Direct Mode	
Status	Value
100 - OK	don't care

Example

Rotate left motor 0, velocity 500.

Binary Form of ROL 0, 51200	
Field	Value
Target address	01 _h
Instruction number	02 _h
Type	00 _h
Motor/Bank	00 _h
Value (Byte 3)	00 _h
Value (Byte 2)	00 _h
Value (Byte 1)	C8 _h
Value (Byte 0)	00 _h
Checksum	CB _h



7.5.3 MST (Motor Stop)

The motor is instructed to stop with a soft stop.

Internal function: The velocity mode is selected. Then, the target velocity (axis parameter #40) is set to zero.

Related commands: ROR, ROL, SAP, GAP.

Binary Representation			
Instruction	Type	Motor/Bank	Value
3	0	0	0

Reply in Direct Mode	
Status	Value
100 - OK	don't care

Example

Stop motor 0.

Binary Form of MST 0	
Field	Value
Target address	01 _h
Instruction number	03 _h
Type	00 _h
Motor/Bank	00 _h
Value (Byte 3)	00 _h
Value (Byte 2)	00 _h
Value (Byte 1)	00 _h
Value (Byte 0)	00 _h
Checksum	04 _h



7.5.4 MVP (Move to Position)

With this command the motor will be instructed to move to a specified relative or absolute position. It will use the acceleration/deceleration ramp and the positioning speed programmed into the unit. This command is non-blocking - that is, a reply will be sent immediately after command interpretation and initialization of the motion controller. Further commands may follow without waiting for the motor reaching its end position. The maximum velocity and acceleration as well as other ramp parameters are defined by the appropriate axis parameters. For a list of these parameters please refer to section 9. The range of the MVP command is 32 bit signed (-2147483648...2147483647). Positioning can be interrupted using MST, ROL or ROR commands.

Two operation types are available:

- Moving to an absolute position in the range from -2147483648...2147483647 ($-2^{31} \dots 2^{31} - 1$).
- Starting a relative movement by means of an offset to the actual position. In this case, the new resulting position value must not exceed the above mentioned limits, too.

Note The distance between the actual position and the new position must not be more than 2147483647 ($2^{31} - 1$) position steps. Otherwise the motor will run in the opposite direction in order to take the shorter distance (caused by 32 bit overflow).

Internal function: A new position value is transferred to the axis parameter #0 (target position).

Related commands: SAP, GAP, MST.

Binary Representation			
Instruction	Type	Motor/Bank	Value
4	0 - ABS - absolute	0	<position>
	1 - REL - relative	0	<offset>

Reply in Direct Mode	
Status	Value
100 - OK	don't care

Example

Move motor 0 to position 90000.



Binary Form of MVP ABS, 0, 90000	
Field	Value
Target address	01 _h
Instruction number	04 _h
Type	00 _h
Motor/Bank	00 _h
Value (Byte 3)	00 _h
Value (Byte 2)	01 _h
Value (Byte 1)	5F _h
Value (Byte 0)	90 _h
Checksum	F5 _h

Example

Move motor 0 from current position 10000 steps backward.

Binary Form of MVP REL, 0, -10000	
Field	Value
Target address	01 _h
Instruction number	04 _h
Type	01 _h
Motor/Bank	00 _h
Value (Byte 3)	FF _h
Value (Byte 2)	FF _h
Value (Byte 1)	D8 _h
Value (Byte 0)	F0 _h
Checksum	CC _h



7.5.5 SAP (Set Axis Parameter)

With this command most of the motion control parameters of the module can be specified. The settings will be stored in SRAM and therefore are volatile. That is, information will be lost after power off.

Info

For a table with parameters and values which can be used together with this command please refer to section 9.

Internal function: The specified value is written to the axis parameter specified by the parameter number.

Related commands: GAP, AAP.

Binary representation

Binary Representation			
Instruction	Type	Motor/Bank	Value
5	see chapter 9	0	<value>

Reply in Direct Mode	
Status	Value
100 - OK	don't care

Example Set the maximum positioning velocity to 51200 rpm.

Binary Form of SAP 43, 0, 4000	
Field	Value
Target address	01 _h
Instruction number	05 _h
Type	2B _h
Motor/Bank	00 _h
Value (Byte 3)	00 _h
Value (Byte 2)	00 _h
Value (Byte 1)	0F _h
Value (Byte 0)	A0 _h
Checksum	D2 _h



7.5.6 GAP (Get Axis Parameter)

Most motion / driver related parameters of the TMCM-1617-GRIP-REF can be adjusted using e.g. the SAP command. With the GAP parameter they can be read out. In standalone mode the requested value is also transferred to the accumulator register for further processing purposes (such as conditional jumps). In direct mode the value read is only output in the value field of the reply, without affecting the accumulator.

Info

For a table with parameters and values that can be used together with this command please refer to section 9.

Internal function: The specified value gets copied to the accumulator.

Related commands: SAP, AAP.

Binary Representation			
Instruction	Type	Motor/Bank	Value
6	see chapter 9	0	<value>

Reply in Direct Mode	
Status	Value
100 - OK	value read by this command

Example

Get the actual position of the motor.

Binary Form of GAP 52, 0	
Field	Value
Target address	01 _h
Instruction number	06 _h
Type	36 _h
Motor/Bank	00 _h
Value (Byte 3)	00 _h
Value (Byte 2)	00 _h
Value (Byte 1)	00 _h
Value (Byte 0)	00 _h
Checksum	08 _h



7.5.7 STAP (Store Axis Parameter)

This command is used to store TMCL axis parameters permanently in the EEPROM of the module. This command is mainly needed to store the default configuration of the module. The contents of the user variables can either be automatically or manually restored at power on.

Info

For a table with parameters and values which can be used together with this command please refer to section 9.

Internal function: The axis parameter specified by the type and bank number will be stored in the EEPROM.

Related commands: SAP, AAP, GAP, RSAP.

Binary Representation			
Instruction	Type	Motor/Bank	Value
7	see chapter 9	0	0 (don't care)

Reply in Direct Mode	
Status	Value
100 - OK	0 (don't care)

Example

Store axis parameter #6.

Binary Form of STAP 6, 12	
Field	Value
Target address	01 _h
Instruction number	07 _h
Type	06 _h
Motor/Bank	00 _h
Value (Byte 3)	00 _h
Value (Byte 2)	00 _h
Value (Byte 1)	00 _h
Value (Byte 0)	00 _h
Checksum	0E _h



7.5.8 RSAP (Restore Axis Parameter)

With this command the contents of an axis parameter can be restored from the EEPROM. By default, all axis parameters are automatically restored after power up. An axis parameter that has been changed before can be reset to the stored value by this instruction.

Info

For a table with parameters and values which can be used together with this command please refer to section 9.

Internal function: The axis parameter specified by the type and bank number will be restored from the EEPROM.

Related commands: SAP, AAP, GAP, RSAP.

Binary Representation			
Instruction	Type	Motor/Bank	Value
8	see chapter 9	0	0 (don't care)

Reply in Direct Mode	
Status	Value
100 - OK	0 (don't care)

Example

Restore axis parameter #6.

Binary Form of RSAP 8, 6	
Field	Value
Target address	01 _h
Instruction number	08 _h
Type	06 _h
Motor/Bank	00 _h
Value (Byte 3)	00 _h
Value (Byte 2)	00 _h
Value (Byte 1)	00 _h
Value (Byte 0)	00 _h
Checksum	0A _h



7.5.9 STGP (Store Global Parameter)

This command is used to store TMCL global parameters permanently in the EEPROM of the module. This command is mainly needed to store the TMCL user variables (located in bank 2) in the EEPROM of the module, as most other global parameters (located in bank 0) are stored automatically when being modified. The contents of the user variables can either be automatically or manually restored at power on.

Info

For a table with parameters and values which can be used together with this command please refer to section 10.

Internal function: The global parameter specified by the type and bank number will be stored in the EEPROM.

Related commands: SGP, AGP, GGP, RSGP.

Binary Representation			
Instruction	Type	Motor/Bank	Value
11	see chapter 10	2	0 (don't care)

Reply in Direct Mode	
Status	Value
100 - OK	0 (don't care)

Example

Store user variable #42.

Binary Form of STGP 42, 2	
Field	Value
Target address	01 _h
Instruction number	0B _h
Type	2A _h
Motor/Bank	02 _h
Value (Byte 3)	00 _h
Value (Byte 2)	00 _h
Value (Byte 1)	00 _h
Value (Byte 0)	00 _h
Checksum	38 _h



7.5.10 RSGP (Restore Global Parameter)

With this command the contents of a TMCL user variable can be restored from the EEPROM. By default, all user variables are automatically restored after power up. A user variable that has been changed before can be reset to the stored value by this instruction.

Info

For a table with parameters and values which can be used together with this command please refer to section 10.

Internal function: The global parameter specified by the type and bank number will be restored from the EEPROM.

Related commands: SGP, AGP, GGP, STGP.

Binary Representation			
Instruction	Type	Motor/Bank	Value
12	see chapter 10	2	0 (don't care)

Reply in Direct Mode	
Status	Value
100 - OK	0 (don't care)

Example

Restore user variable #42.

Binary Form of RSGP 42, 2	
Field	Value
Target address	01 _h
Instruction number	0C _h
Type	2A _h
Motor/Bank	02 _h
Value (Byte 3)	00 _h
Value (Byte 2)	00 _h
Value (Byte 1)	00 _h
Value (Byte 0)	00 _h
Checksum	39 _h



7.5.11 TMCL Control Commands

The motor/bank parameter is not used by any of these functions and thus is not listed in the table. It should always be set to 0 with these commands.

TMCL Control Commands			
Instruction	Description	Type	Value
136 – get firmware version	Return firmware version in string format (special reply) or binary format).	0 - string format 1 - binary format	0 (don't care)
137 – restore factory settings	Reset all settings in the EEPROM to their factory defaults. This command does not send a reply.	0 (don't care)	set to 1234
255 – software reset	Restart the CPU of the module (like a power cycle). The reply of this command might not always get through.	0 (don't care)	set to 1234

Table 24: TMCL Control Commands

8 TMCM-1617-GRIP-REF Features over the TMCM-1617 standard TMCL Firmware

A special firmware for the TMCM-1617-GRIP-REF was derived from TMCM-1617 firmware that adds more parameters to demonstrate the basics of the MAX14906 and MAX22000. When using the TMCL-IDE you will see that both Maxim ICs are tied to pseudo axis 1 and 2.



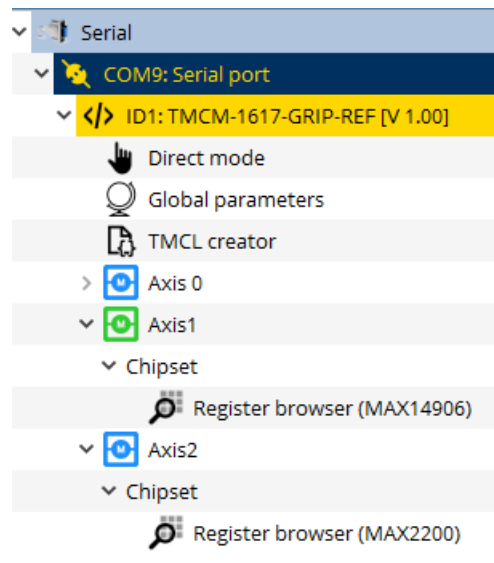

Figure 7: TMCL-IDE viewing pseudo Axis 1 and Axis 2

The available parameters for those two axis can be found in table 34 (MAX14906) and table 35 (MAX22000). Beware, that these parameters cannot be stored non-volatile. Through the TMCL-IDE you also have read- and write access to all registers of both Maxim ICs via the register browser.

8.1 Digital IOs

After power-on, all digital IOs are set to output but are disabled. To activate all output pins, the axis 1 "Enable" parameter must be set to 1. Then the logical state of each output pin can be changed by the "DO Level DOli" axis 1 parameters (number 10 to 13; check out table 35).

When one or more IOs are configured as digital input pin (by the "Pin mode DOli" axis parameter number 2 to 5), the input mode configured by axis 1 parameter 1 "DI Mode" is valid for all input IOs.

8.2 Analog output

The 18-bit analog output can either be used in voltage- or current output mode. To select the desired mode and range, axis 2 parameter "AOI0 Mode" must be changed.

Axis 2 parameter 1 "DAC Value"	Output voltage
-131072	-12.5 V
0	0 V
131071	12.4999 V

Table 25: AOI0 Mode: 2 (Analog output voltage mode, ±12.5V setting)

In voltage output mode, make sure the load dose not drop below 1 kΩ.



Axis 2 parameter 1 "DAC Value"	Output current
-131072	-25 mA
0	0 mA
131071	24.9998 mA

Table 26: AOI0 Mode: 3 (Analog output current mode, ±25mA setting)

In current output mode, make sure the load dose not exceed 500 Ω.

Axis 2 parameter 1 "DAC Value"	Output current
-131072	-2.5 mA
0	0 mA
131071	2.49998 mA

Table 27: AOI0 Mode: 4 (Analog output current mode, ±2.5mA setting)

Note

The analog output comes not factory-calibrated, and on any power-on, the calibration gain and offset must be rewritten to the corresponding axis parameter. Thus the host device is responsible to store the calibration values non-volatile.

8.3 Analog input

The analog input has a 24-bit resolution.

Axis 2 parameter 7 "ADC Value"	Input voltage
-8388600	-25V
0	0V
8388607	25V

Table 28: AI1/AI2 Mode: 1 (Analog input differential ±25V)

Axis 2 parameter 7 "ADC Value"	Input voltage
-8388600	-2.5V
0	0V
8388607	2.5V

Table 29: AI1/AI2 Mode: 2 (Analog input differential ±2.5V)



Axis 2 parameter 7 "ADC Value"	Input voltage
-8388600	-500 mV
0	0 mV
8388607	500 mV

Table 30: AI1/AI2 Mode: 3 (Analog input differential $\pm 500\text{mV}$)

Axis 2 parameter 7 "ADC Value"	Input voltage
-8388600	-250 mV
0	0 mV
8388607	250 mV

Table 31: AI1/AI2 Mode: 4 (Analog input differential $\pm 250\text{mV}$)

Axis 2 parameter 7 "ADC Value"	Input voltage
-8388600	-125 mV
0	0 mV
8388607	125 mV

Table 32: AI1/AI2 Mode: 5 (Analog input differential $\pm 125\text{mV}$)

Note

The analog input comes not factory-calibrated, and on any power-on, the calibration gain and offset must be rewritten to the corresponding axis parameter. Thus the host device is responsible to store the calibration values non-volatile.



9 Axis Parameters

Most motor controller features of the TMCM-1617-GRIP-REF module are controlled by axis parameters. Axis parameters can be modified or read using SAP (W), GAP (R) and commands. Axis parameters that are flagged with an E in the access column can also be stored to or restored from the EEPROM using STAP and RSAP commands. This chapter describes all axis parameters that can be used on the TMCM-1617-GRIP-REF module.

Axis 0 Parameters of the TMCM-1617-GRIP-REF Module					
Number	Axis Parameter	Description	Range [Units]	Default	Access
0	adc_i0_raw	Raw adc measurement of the phase_A shunt	0 ... 65535	32767	R
1	adc_i1_raw	Raw adc measurement of the phase_B shunt	0 ... 65535	32767	R
2	adc_i0	Calculated current measurement for phase_A shunt and used offset	-32768 ... 32767	0	R
3	adc_i1	Calculated current measurement for phase_B shunt and used offset	-32768 ... 32767	0	R
4	adc_i2	Calculated current of phase_C from phase_A and phase_B measurements	-32768 ... 32767	0	R
5	adc_i0_offset	Manually set/get the dual-shunt phase_A offset.	0 ... 65535	33500	RWE
6	adc_i1_offset	Manually set/get the dual-shunt phase_B offset.	0 ... 65535	33500	RWE
10	motor pole pairs	Number of motor poles.	1 ... 255	4	RWE
11	max current	Max. allowed absolute motor current. *This value can be temporarily exceeded marginal due to the operation of the current regulator.	0 ... 3000 [mA]	2500	RWE
12	open loop current	Motor current for controlled commutation. This parameter is used in commutation mode 1.	0 ... 3000 [mA]	800	RWE
13	motor direction		0 ... 1	0	RWE
14	motor type	Select your motor type. 0 - No motor 1 - Single phase DC 3 - Three phase BLDC	0 ... 3	0	RWE
15	commutation mode	Select a commutation mode that fits best to your motor's sensors. 0 - disabled 1 - open loop 2 - digital hall 3 - ABN encoder	0 ... 3	0	RWE



Number	Axis Parameter	Description	Range [Units]	Default	Access
16	open loop commutation angle	Actual controlled angle value.	-32768 ... 32767	0	R
17	encoder commutation angle	Actual encoder angle value.	-32768 ... 32767	0	R
18	digital hall commutation angle	Actual digital hall angle value.	-32768 ... 32767	0	R
20	encoder/open loop commutation angle diff	Actual encoder and open loop angle difference.	-32768 ... 32767	0	R
21	digital hall/open loop commutation angle diff	Actual encoder and open loop angle difference.	-32768 ... 32767	0	R
30	target current	Get desired target current or set target current to activate current regulation mode. (+= turn motor in right direction; -= turn motor in left direction)	-18000 ... 18000 [mA]	0	RW
31	actual current	The actual motor current.	-2147483648 ... 2147483647 [mA]	0	R
32	target flux	Get desired target flux or set target flux to activate current regulation mode.	-18000 ... 18000 [mA]	0	RW
33	actual flux	The actual motor flux.	-2147483648 ... 2147483647 [mA]	0	R
40	target velocity	The desired target velocity.	-200000 ... 200000 [rpm]	0	RW
41	ramp velocity	The actual velocity of the velocity ramp used for positioning and velocity mode.	-200000 ... 200000 [rpm]	0	R
42	actual velocity	The actual velocity of the motor.	-2147483648 ... 2147483647 [rpm]	0	R
43	max velocity	Max. absolute velocity for velocity and positioning mode.	0 ... 200000 [rpm]	4000	RWE
44	acceleration	Acceleration parameter for ROL, ROR, and the velocity ramp of MVP.	0 ... 100000 [rpm/s]	2000	RWE



Number	Axis Parameter	Description	Range [Units]	Default	Access
45	enable velocity ramp	An activated ramp allows a defined acceleration for velocity and position mode. 0 - Deactivate velocity ramp generator. 1 - Activate velocity ramp generator.	0 ... 1	1	RWE
50	target position	The target position of a currently executed ramp.	-2147483648 ... 2147483647	0	RW
51	ramp position	The actual position of the position ramp used for positioning mode.	-2147483648 ... 2147483647	0	R
52	actual position	The actual position counter.	-2147483648 ... 2147483647	0	RW
53	position reached distance	Maximum distance at which the position end flag is set.	0 ... 100000	5	RWE
54	position reached velocity	Max. velocity at which end position flag can be set. Prevents issuing of end position flag when the target is passed at high velocity.	0 ... 200000 [rpm]	500	RWE
55	position reached flag	This flag is set when actual position and velocity matches target position window. 0 - Position window not reached 1 - Position window reached	0 ... 1	0	R
56	position scaler	Scale the external position (external_position = (internal_position * scaler)/65536.	6 ... 2147483647	65536	RWE
70	torque P	P parameter for current PID regulator	0 ... 32767	300	RWE
71	torque I	I parameter for current PID regulator	0 ... 32767	300	RWE
72	velocity P	P parameter for velocity PID regulator	0 ... 32767	300	RWE
73	velocity I	I parameter for velocity PID regulator	0 ... 32767	100	RWE
74	position P	P parameter for position PID regulator	0 ... 32767	200	RWE
75	torque PI error sum	Sum of errors of current PI regulator.	-2147483648 ... 2147483647	0	R
76	flux PI error sum	Sum of errors of flux PI regulator.	-2147483648 ... 2147483647	0	R
77	velocity PI error sum	Sum of errors of velocity PI regulator.	-2147483648 ... 2147483647	0	R
78	torque PI error	Error of torque PI regulator.	-2147483648 ... 2147483647	0	R



Number	Axis Parameter	Description	Range [Units]	Default	Access
79	flux PI error	Error of flux PI regulator.	-2147483648 ...2147483647	0	R
80	velocity PI error	Error of velocity PI regulator.	-2147483648 ...2147483647	0	R
81	position PI error	Error of position PI regulator.	-2147483648 ...2147483647	0	R
90	hall polarity	Hall sensor polarity. 0 - standard 1 - inverted	0 ... 1	0	RWE
91	hall direction	Hall sensor direction. 0 - standard 1 - inverted	0 ... 1	0	RWE
92	hall interpolation	Hall sensor interpolation. 0 - off 1 - on	0 ... 1	0	RWE
93	hall phi_e offset	Offset for electrical angle hall_phi_e of hall sensor.	-32768 ... 32767	0	RWE
94	hall inputs	Raw hall sensor inputs.	0 ... 7	0	R
100	encoder steps	Encoder steps per full motor rotation.	0 ... 16777215	4096	RWE
101	encoder direction	Set the encoder direction in a way, that ROR increases position counter. 0 - standard 1 - inverted	0 ... 1	0	RWE
102	encoder init mode	Select an encoder init mode that fits best to your motor's sensors. 0 - estimate offset 2 - use hall	0 ... 2	0	RWE
103	encoder init state	Actual state of encoder initialization. 0 - nothing to do 1 - start_init 2 - wait_init_time 3 - estimate_offset	0 ... 3	0	R
104	encoder init delay	Duration for encodersine initialization sequence. This parameter should be set in a way, that the motor has stopped mechanical oscillations after the specified time.	0 ... 10000 [ms]	1000	RWE
105	encoder init velocity	Init velocity for encoder initialization with encoder N-channel.	-200000 ... 200000 [rpm]	100	RWE
106	encoder offset	This value represents the internal commutation offset. (0...max. encoder steps per rotation).	0 ... 65535	0	RWE



Number	Axis Parameter	Description	Range [Units]	Default	Access
107	clear on null	Clear the position counter on encoder N channel. 0 - do not clear position counter at next N channel event 1 - set position counter to zero at next N channel event	0 ... 1	0	RWE
108	clear once	Clear the position counter on encoder N channel. 0 - clear position counter always at an N channel event 1 - set position counter to zero only once	0 ... 1	0	RWE
109	encoder inputs	Raw ABN encoder inputs.	0 ... 7	0	R
110	Motor PWM frequency	Sets the frequency of the motor PWM.	25000 ... 100000 [Hz]	25000	RWE
140	enable brake chopper	Enable brake chopper functionality. 0 - Deactivate brake chopper. 1 - Activate brake chopper.	0 ... 1	0	RWE
141	brake chopper voltage limit	If the brake chopper is enabled and supply voltage exceeds this value, the brake chopper output will be activated.	60 ... 300 [0.1V]	300	RWE
142	brake chopper hysteresis	An activated brake chopper will be disabled if the actual supply voltage is lower than (limit voltage-hysteresis).	0 ... 50 [0.1V]	5	RWE
156	status flags	Actual status flags.	0 ... 0	0	R
220	supply voltage	The actual supply voltage.	0 ... 1000 [0.1V]	240	R
221	driver temperature	The actual temperature of the motor driver.	-20 ... 150 [°C]	0	R
255	enable driver	Enables the motor driver (enabled by default) 0 - driver disabled 1 - driver enabled	0 ... 1	1	RW

Table 33: All TMCM-1617-GRIP-REF Axis 0 Parameters

Axis 1 Parameters of the TMCM-1617-GRIP-REF Module					
Number	Axis Parameter	Description	Range [Units]	Default	Access
0	Enable	Enable digital outputs 0 - outputs disabled 1 - outputs enabled	0 ... 1	0	RW



Number	Axis Parameter	Description	Range [Units]	Default	Access
1	DI mode	Digital input mode for all DIOs configured as digital input 0 - Type 1 and 3 1 - Type 2	0 ... 1	0	RW
2	Pin mode DOI1	Pin mode 0 - Digital Output (DO) 1 - Digital Input (DI) 2 - Low-leakage, High-impedance	0 ... 2	0	RW
3	Pin mode DOI2	Pin mode 0 - Digital Output (DO) 1 - Digital Input (DI) 2 - Low-leakage, High-impedance	0 ... 2	0	RW
4	Pin mode DOI3	Pin mode 0 - Digital Output (DO) 1 - Digital Input (DI) 2 - Low-leakage, High-impedance	0 ... 2	0	RW
5	Pin mode DOI4	Pin mode 0 - Digital Output (DO) 1 - Digital Input (DI) 2 - Low-leakage, High-impedance	0 ... 2	0	RW
6	DO mode DOI1	Digital output mode 0 - High-side 1 - High-side with 2x inrush current for t_INRUSH time 2 - Active clamp push-pull 3 - Simple push-pull	0 ... 3	0	RW
7	DO mode DOI2	Digital output mode 0 - High-side 1 - High-side with 2x inrush current for t_INRUSH time 2 - Active clamp push-pull 3 - Simple push-pull	0 ... 3	0	RW
8	DO mode DOI3	Digital output mode 0 - High-side 1 - High-side with 2x inrush current for t_INRUSH time 2 - Active clamp push-pull 3 - Simple push-pull	0 ... 3	0	RW
9	DO mode DOI4	Digital output mode 0 - High-side 1 - High-side with 2x inrush current for t_INRUSH time 2 - Active clamp push-pull 3 - Simple push-pull	0 ... 3	0	RW
10	DO Level DOI1	Digital output set 0 - Low 1 - High	0 ... 1	0	RW



Number	Axis Parameter	Description	Range [Units]	Default	Access
11	DO Level DOI2	Digital output set 0 - Low 1 - High	0 ... 1	0	RW
12	DO Level DOI3	Digital output set 0 - Low 1 - High	0 ... 1	0	RW
13	DO Level DOI4	Digital output set 0 - Low 1 - High	0 ... 1	0	RW
14	DOI Status DOI1	Digital output/input status 0 - Low 1 - High	0 ... 1	0	R
15	DOI Status DOI2	Digital output/input status 0 - Low 1 - High	0 ... 1	0	R
16	DOI Status DOI3	Digital output/input status 0 - Low 1 - High	0 ... 1	0	R
17	DOI Status DOI4	Digital output/input status 0 - Low 1 - High	0 ... 1	0	R

Table 34: All TMCM-1617-GRIP-REF Axis 1 Parameters

Axis 2 Parameters of the TMCM-1617-GRIP-REF Module					
Number	Axis Parameter	Description	Range [Units]	Default	Access
0	AOI0 Mode	Analog output mode 0 - High Impedance 1 - Analog output voltage mode, +25V setting; not working correctly! 2 - Analog output voltage mode, ±12.5V setting 3 - Analog output current mode, ±25mA setting 4 - Analog output current mode, ±2.5mA setting	0 ... 4	0	RW
1	DAC Value	Sets the analog output.	-131072 ... 131071	0	RW
2	DAC Calibration Gain	Adjust the analog output gain.	0 ... 262143	256250	RW
3	DAC Calibration Offset	Adjust the analog output offset.	-131072 ... 131071	0	RW



Number	Axis Parameter	Description	Range [Units]	Default	Access
6	AI1/AI2 Mode	Select analog input voltage range. 0 - Power Down 1 - Analog input differential $\pm 25V$ ¹ (Ch1) 2 - Analog input differential $\pm 2.5V$ (Ch2) 3 - Analog input differential $\pm 500mV$ (Ch2) 4 - Analog input differential $\pm 250mV$ (Ch2) 5 - Analog input differential $\pm 125mV$ (Ch2)	0 ... 10	0	RW
7	ADC Value	Sets the analog output to the given value.	-8388608 ... 8388607	0	R
8	ADC Ch1 Calibration Gain	Adjust the analog output gain for the $\pm 25V$ mode.	0 ... 16777215	12582912	RW
9	ADC Ch1 Calibration Offset	Adjust the analog output offset for the $\pm 25V$ mode.	-8388608 ... 8388607	0	RW
10	ADC Ch2 Calibration Gain	Adjust the analog output gain for the $\pm 2.5V$ to $\pm 125mV$ modes.	0 ... 16777215	12582912	RW
11	ADC Ch2 Calibration Offset	Adjust the analog output offset for the $\pm 2.5V$ to $\pm 125mV$ modes.	-8388608 ... 8388607	0	RW

Table 35: All TMCM-1617-GRIP-REF Axis 2 Parameters

¹ only $\pm 15V$ can be measured effectively



10 Global Parameters

The following sections describe all global parameters that can be used with the SGP, GGP, AGP, STGP and RSGP commands. Global parameters are grouped into banks:

- Bank 0: Global configuration of the module.

10.1 Bank 0

Parameters with numbers from 64 on configure all settings that affect the overall behaviour of a module. These are things like the serial address, the RS485 baud rate or the CAN bit rate (where appropriate). Change these parameters to meet your needs. The best and easiest way to do this is to use the appropriate functions of the TMCL-IDE. The parameters with numbers between 64 and 128 are automatically stored in the EEPROM.

Note

- An SGP command on such a parameter will always store it permanently and no extra STGP command is needed.
- Take care when changing these parameters, and use the appropriate functions of the TMCL-IDE to do it in an interactive way.
- Some configurations of the interface (for example baud rates that are not supported by the PC) may lead to the fact that the module cannot be reached any more. In such a case please see the TMCM-1617-GRIP-REF Hardware Manual on how to reset all parameters to factory default settings.
- Some settings (especially interface bit rate settings) do not take effect immediately. For those settings, power cycle the module after changing them to make the changes take effect.

There are different parameter access types, like read only or read/write. Table 36 shows the different parameter access types used in the global parameter tables.

Meaning of the Letters in the Access Column		
Access type	Command	Description
R	GGP	Parameter readable
W	SGP, AGP	Parameter writable
E	STGP, RSGP	Parameter can be stored in the EEPROM
A	SGP	Automatically stored in the EEPROM

Table 36: Meaning of the Letters in the Access Column



All Global Parameters of the TMCM-1617-GRIP-REF Module in Bank 0					
Number	Global Parameter	Description	Range [Units]	Default	Access
65	serial baud rate	RS485 baud rate 0 - 9600 [kBit/s] 1 - 14400 [kBit/s] 2 - 19200 [kBit/s] 3 - 28800 [kBit/s] 4 - 38400 [kBit/s] 5 - 57600 [kBit/s] 6 - 76800 [kBit/s] 7 - 115200 [kBit/s]	0 ... 7	7	RWA
66	serial address	The module (target) address for RS485, and virtual COM port.	1 ... 255	1	RWA
75	telegram pause time	Pause time before the reply via RS485 is sent.	0 ... 255 [ms]	0	RWA
76	serial host address	Host address used in the reply telegrams sent back via RS485.	1 ... 255	2	RWA

Table 37: All Global Parameters of the TMCM-1617-GRIP-REF Module in Bank 0



11 Figures Index

1	TMCM-1617-GRIP-REF dimensions . . .	6	5	IO-Link connector (J202)	9
2	Heat sink mounting	7	6	Supply and RS485 connector (J203) . .	10
3	TMCM-1617-GRIP-REF connectors (bottom view)	8	7	TMCL-IDE viewing pseudo Axis 1 and Axis 2	36
4	EtherCAT® connector (J201)	9			



12 Tables Index

1	Order code	4	26	AOIO Mode: 3 (Analog output current mode, $\pm 25\text{mA}$ setting)	37
2	EtherCAT® LEDs (D303-D305)	9	27	AOIO Mode: 4 (Analog output current mode, $\pm 2.5\text{mA}$ setting)	37
3	Motor connector (PTH203-PTH205)	10	28	AI1/AI2 Mode: 1 (Analog input differential $\pm 25\text{V}$)	37
4	Brake output connector (PTH206-PTH207)	10	29	AI1/AI2 Mode: 2 (Analog input differential $\pm 2.5\text{V}$)	37
5	Hall sensor connector (J206)	11	30	AI1/AI2 Mode: 3 (Analog input differential $\pm 500\text{mV}$)	38
6	ABN Encoder connector (J205)	11	31	AI1/AI2 Mode: 4 (Analog input differential $\pm 250\text{mV}$)	38
7	Analog I/O connector (J204)	11	32	AI1/AI2 Mode: 5 (Analog input differential $\pm 125\text{mV}$)	38
8	Analog I/O modes	12	33	All TMCM-1617-GRIP-REF Axis 0 Parameters	43
9	Digital I/O connector (J207)	13	34	All TMCM-1617-GRIP-REF Axis 1 Parameters	45
10	Programming connector (J301)	13	35	All TMCM-1617-GRIP-REF Axis 2 Parameters	46
11	Absolute Maximum Ratings	14	36	Meaning of the Letters in the Access Column	47
12	IO-Link Electrical Characteristics	14	37	All Global Parameters of the TMCM-1617-GRIP-REF Module in Bank 0	48
13	RS485 Electrical Characteristics	15	38	Hardware Revision	53
14	Hall Sensor Electrical Characteristics	15	39	Firmware Revision	53
15	Encoder Electrical Characteristics	15	40	Document Revision	53
16	Analog I/O Electrical Characteristics	15			
17	Digital I/O Electrical Characteristics	16			
18	TMCL Command Format	19			
19	TMCL Reply Format	20			
20	TMCL Status Codes	21			
21	Overview of all TMCL Commands	22			
22	Motion Commands	22			
23	Parameter Commands	23			
24	TMCL Control Commands	35			
25	AOIO Mode: 2 (Analog output voltage mode, $\pm 12.5\text{V}$ setting)	36			



13 Supplemental Directives

13.1 Producer Information

13.2 Copyright

TRINAMIC owns the content of this user manual in its entirety, including but not limited to pictures, logos, trademarks, and resources. © Copyright 2021 TRINAMIC. All rights reserved. Electronically published by TRINAMIC, Germany.

Redistribution of sources or derived formats (for example, Portable Document Format or Hypertext Markup Language) must retain the above copyright notice, and the complete data sheet, user manual, and documentation of this product including associated application notes; and a reference to other available product-related documentation.

13.3 Trademark Designations and Symbols

Trademark designations and symbols used in this documentation indicate that a product or feature is owned and registered as trademark and/or patent either by TRINAMIC or by other manufacturers, whose products are used or referred to in combination with TRINAMIC's products and TRINAMIC's product documentation.

This HW & TMCL FW Manual is a non-commercial publication that seeks to provide concise scientific and technical user information to the target user. Thus, trademark designations and symbols are only entered in the Short Spec of this document that introduces the product at a quick glance. The trademark designation /symbol is also entered when the product or feature name occurs for the first time in the document. All trademarks and brand names used are property of their respective owners.

13.4 Target User

The documentation provided here, is for programmers and engineers only, who are equipped with the necessary skills and have been trained to work with this type of product.

The Target User knows how to responsibly make use of this product without causing harm to himself or others, and without causing damage to systems or devices, in which the user incorporates the product.

13.5 Disclaimer: Life Support Systems

TRINAMIC Motion Control GmbH & Co. KG does not authorize or warrant any of its products for use in life support systems, without the specific written consent of TRINAMIC Motion Control GmbH & Co. KG.

Life support systems are equipment intended to support or sustain life, and whose failure to perform, when properly used in accordance with instructions provided, can be reasonably expected to result in personal injury or death.

Information given in this document is believed to be accurate and reliable. However, no responsibility is assumed for the consequences of its use nor for any infringement of patents or other rights of third parties which may result from its use. Specifications are subject to change without notice.

13.6 Disclaimer: Intended Use

The data specified in this user manual is intended solely for the purpose of product description. No representations or warranties, either express or implied, of merchantability, fitness for a particular purpose



or of any other nature are made hereunder with respect to information/specification or the products to which information refers and no guarantee with respect to compliance to the intended use is given.

In particular, this also applies to the stated possible applications or areas of applications of the product. TRINAMIC products are not designed for and must not be used in connection with any applications where the failure of such products would reasonably be expected to result in significant personal injury or death (safety-Critical Applications) without TRINAMIC's specific written consent.

TRINAMIC products are not designed nor intended for use in military or aerospace applications or environments or in automotive applications unless specifically designated for such use by TRINAMIC. TRINAMIC conveys no patent, copyright, mask work right or other trade mark right to this product. TRINAMIC assumes no liability for any patent and/or other trade mark rights of a third party resulting from processing or handling of the product and/or any other use of the product.

13.7 Collateral Documents & Tools

This product documentation is related and/or associated with additional tool kits, firmware and other items, as provided on the product page at: www.trinamic.com.



14 Revision History

14.1 Hardware Revision

Version	Date	Author	Description
1.0	12.02.2021	MM	

Table 38: Hardware Revision

14.2 Firmware Revision

Version	Date	Author	Description
1.01	06.05.2021	BP	Launch release.

Table 39: Firmware Revision

14.3 Document Revision

Version	Date	Author	Description
1.01	07.05.2021	MM/BP	Launch release.

Table 40: Document Revision

