



SVPL3R306SG SERIES

SPACE QUALIFIED POINT OF LOAD CONVERTERS



SVPL Series DC-DC Converter

Models Available

Input: 3.1 V to 5.5 V
6 A output
Qualified to MIL-PRF-38534 Class H and Class K

1.0 DESCRIPTION

The SVPL Series of space qualified point-of-load DC-DC converters is specifically designed for the harsh radiation environment of space applications. Performance is guaranteed through the use of hardened semiconductor components and analysis. The SVPL Series has been characterized for Total Ionizing Dose (TID) performance including Enhanced Low Dose Rate Sensitivity (ELDRS) and for Single Event Effects (SEE) per VPT's DLA-approved Radiation Hardness Assurance (RHA) plan per MIL-PRF-38534, Appendix G, Level R.

The SVPL3R306SG is based on the Intersil ISL70001ASEH radiation-hardened monolithic buck regulator. It is designed to operate from a nominal 3.3 V or 5 V bus. The SVPL3R306SG supplies low voltages at 6 A with high efficiency and fast transient response, making it an ideal choice to supply point-of-load applications such as high-performance space processors.

1.1 FEATURES

- Operates from 3.1 – 5.5 V input
- Adjustable Output from 0.8 – 3.8 V
- Up to 6 Amps Output
- High Efficiency, up to 95%
- High Power Density, up to 67 W/in³
- Output Enable Control
- Low Output Noise
- Over Current Protection
- Bi-directional SYNC pin allows devices to be synchronized 180° out-of-phase

1.2 SPACE LEVEL CHARACTERIZATIONS

- Total Ionizing Dose Performance
 - High Dose Rate [50-300 rad(Si)/s] ≥ 100 krad(Si)
 - Low Dose Rate [<10 mrad(Si)/s] ≥ 100 krad(Si)
- Single Event Effects Performance
 - SEL, SEB, and SEGR LET_{TH} ≥ 85 MeV/mg/cm²
 - SEFI Threshold LET_{TH} ≥ 42 MeV/mg/cm²
 - SEFI X-section (LET_{EFF} = 85 MeV/mg/cm²) ≤ 8.25x10⁻⁷ cm²
 - SET fully characterized for cross section and magnitude
- Operation from -55 °C to +125 °C
- Worst-case analysis, stress, radiation, reliability reports available

1.3 MANUFACTURING AND COMPLIANCE

- Qualified to MIL-PRF-38534 Class H and Class K, DLA SMD # 5962-17215
- MIL-PRF-38534 element evaluated components
- Manufactured in a MIL-PRF-38534 Class H and Class K facility
- MIL-STD-883
- ISO-9001

1.4 PACKAGING

- Low-profile: 1.110" x 1.110" x 0.276"
- Max weight: 21 g
- Precision seam-welded hermetic metal case
- Standard gullwing or optional straight-lead versions available

1.5 SIMILAR PRODUCTS AND ACCESSORIES

- [SVGA0510S](#) 10 A space qualified point of load DC-DC converter
- [SVRGA0508S](#) 8 A space qualified point of load DC-DC converter
- Custom versions available
- [Space qualified isolated DC-DC converters](#), 6 - 100 W
- [EMI filters](#)

Products and reports described in this datasheet are subject to all export license restrictions and regulations which may include but are not limited to ITAR (International Traffic in Arms Regulations) and the Export Administration and Foreign Assets Control Regulations. Further restrictions may apply. Contact VPT sales for details. VPT, its logo and tagline are registered trademarks in the U.S. Patent and Trademark Office. All other names, product names and trade names may be trademarks or registered trademarks of their respective holders.

2.0 DIAGRAMS

2.1 BLOCK DIAGRAM

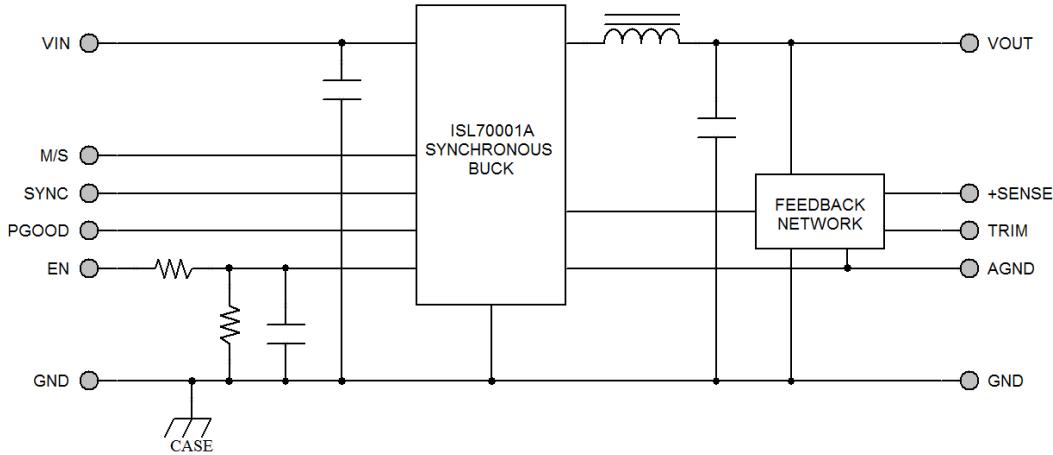

2.2 CONNECTION DIAGRAMS

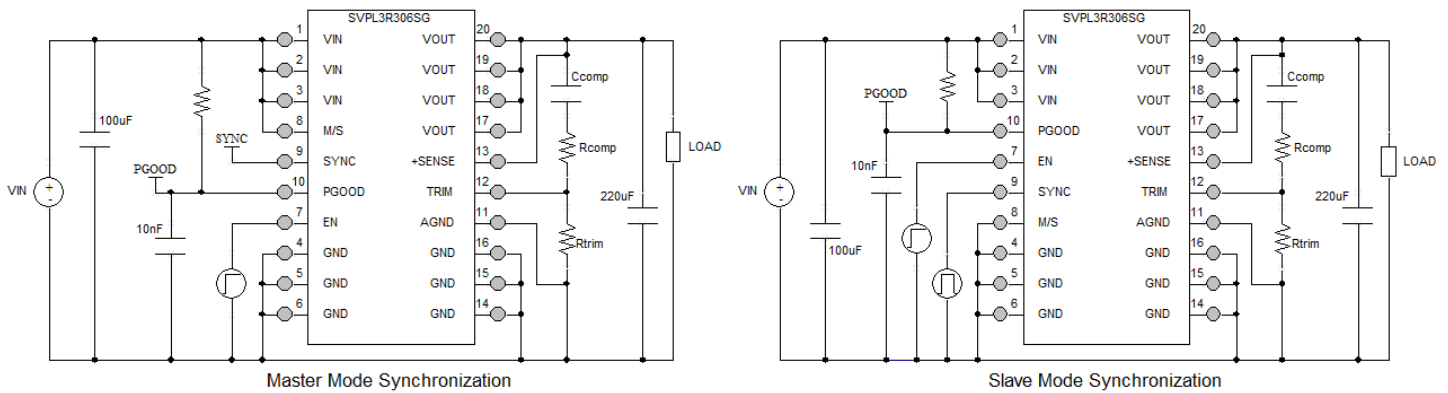

1. Rtrim should be connected directly across pins 11 and 12 as close as possible to the SVPL.
2. AGND should be connected to GND close to the SVPL. Voltage difference between the AGND and the GND pins greater than 0.3 V may result in regulation error and/or damage to the SVPL.
3. If not using EN, connect pin 7 to VIN.
4. If not synchronizing converters, use Master Mode Synchronization connections and leave pin 9 open.
5. If not using PGOOD, leave pin 10 open.
6. Rcomp and Ccomp are optional components that can be used to optimize the SVPL transient response.

3.0 SPECIFICATIONS

3.1 ABSOLUTE MAXIMUM RATINGS

Absolute Maximum Ratings			
VIN, PGOOD ¹ :	-0.3 V to 6.5 V	Operating Temperature (Full Load):	-55 °C to +125 °C
EN, M/S, SYNC	-0.3 V to Vin + 0.3 V	Storage Temperature:	-65 °C to +150 °C
AGND	-0.3 V to 0.3 V	Lead Solder Temperature (10 seconds):	270 °C
ESD Rating per MIL-PRF-38534:	1C	Solder Reflow Temperature (30 seconds):	220 °C

1. Limited to 5.7 V for operation in a heavy ion environment at LET ≥ 85 MeV/mg/cm² and Tcase = 125 °C.

3.2 PERFORMANCE SPECIFICATIONS¹

T_{case} = -55 °C to +125 °C, V_{in} = +5 V ± 1% or 3.3 V ± 1%, Full Load, Unless Otherwise Specified

Parameter	Conditions	SVPL3R306SG			Units
		Min	Typ	Max	
INPUT					
Voltage ²		3.1	-	5.5	V
Current	EN = GND, V _{in} = 5 V	-	5	12	mA
	EN = GND, V _{in} = 3.3 V	-	4	12	mA
	EN = V _{in} = 5 V, No Load	-	45	60	mA
	EN = V _{in} = 3.3 V, No Load	-	25	60	mA
Undervoltage Lockout	Rising Threshold ²	2.65	2.8	2.95	V
	Hysteresis ²	0.09	0.175	0.26	V
OUTPUT STATIC					
Voltage	T _{case} = 25 °C	-1.0	-	+1.0	%V _{out}
	T _{case} = -55 °C to +125 °C	-1.5	-	+1.5	%V _{out}
Power ³		0	-	22.8	W
Current		0	-	6	A
Ripple Voltage	20 Hz to 10 MHz	-	15	30	mV _{pp}
Load Regulation		-0.5	0.03	+0.5	%V _{out}
Load Fault Dissipation	V _{in} = 5 V, V _{out} = 3.3 V	-	-	1	W
OUTPUT DYNAMIC					
Load Step, Half to Full Load, V _{out} = 3.3 V	Output Transient	-	35	70	mV
	Recovery ⁴	-	30	60	μs
Turn-On (V _{in} = 0 to 3.3 V or 5 V, EN = V _{in})	Delay	-	5	12	ms
	Overshoot	-	0	15	mV _{pk}
FUNCTION					
Enable (EN) ²	Rising Threshold	1.15	1.31	1.48	V
	Hysteresis	0.058	0.110	0.172	V
	EN Pin Current, EN = 5.5 V	-	-	300	μA
SYNC Frequency Range	V _{in} = 5V, M/S = GND	0.85	1	1.15	MHz
GENERAL					
Efficiency	V _{in} = 5 V, V _{out} = 3.3 V, I _{out} = 6 A	87	92	-	%
Capacitive Load ²		220	-	3300 V _{out}	μF
Switching Frequency	M/S = V _{in}	0.85	1	1.15	MHz
Weight	Standard package option	-	-	21	g
MTBF (MIL-HDBK-217F)	SF @ T _{case} = 55 °C	-	7.04	-	MHr
POST-RAD END-OF-LIFE LIMITS⁵					
OUTPUT Voltage	T _{case} = -55 °C to +125 °C	-3.0	-	+3.0	%V _{out}

1. Performance specifications are guaranteed with 100 μF from VIN to GND and 220 μF from VOUT to GND.
2. Verified by initial electrical design verification. Post design verification, parameter shall be guaranteed to the limits specified.
3. Dependent on output voltage.
4. Time for output voltage to settle within 1% of steady-state value.
5. End-of-Life performance includes aging and radiation degradation and is within standard limits except where noted.

4.0 PERFORMANCE CURVES

4.1.1 SVPL3R306SG Efficiency (Typical, 25 °C, Vin = 3.3 V)

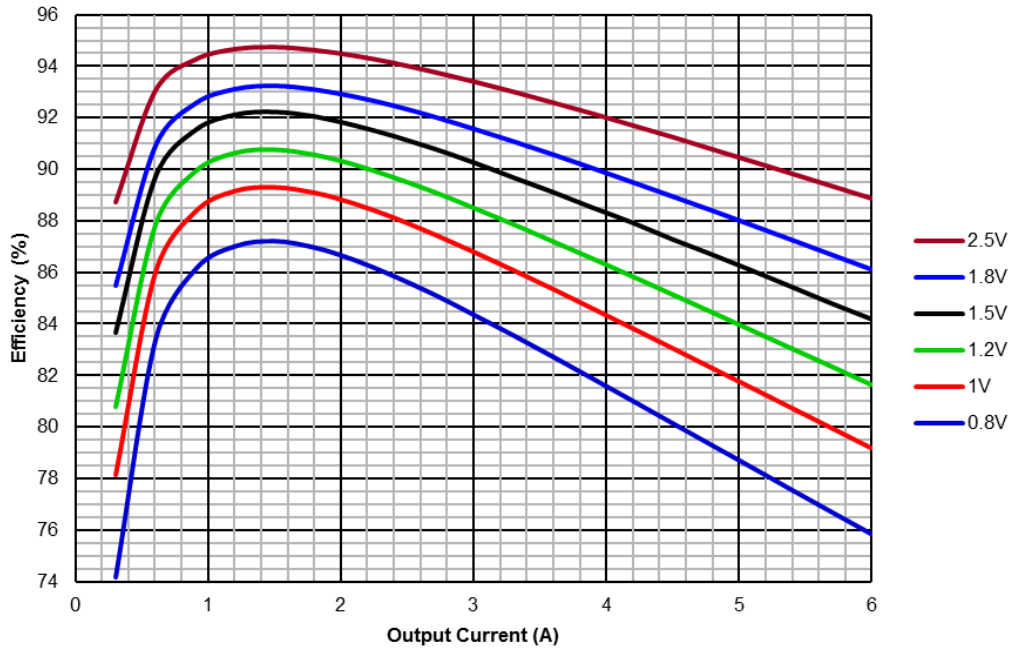

4.1.2 SVPL3R306SG Efficiency (Typical, 25 °C, Vin = 5 V)

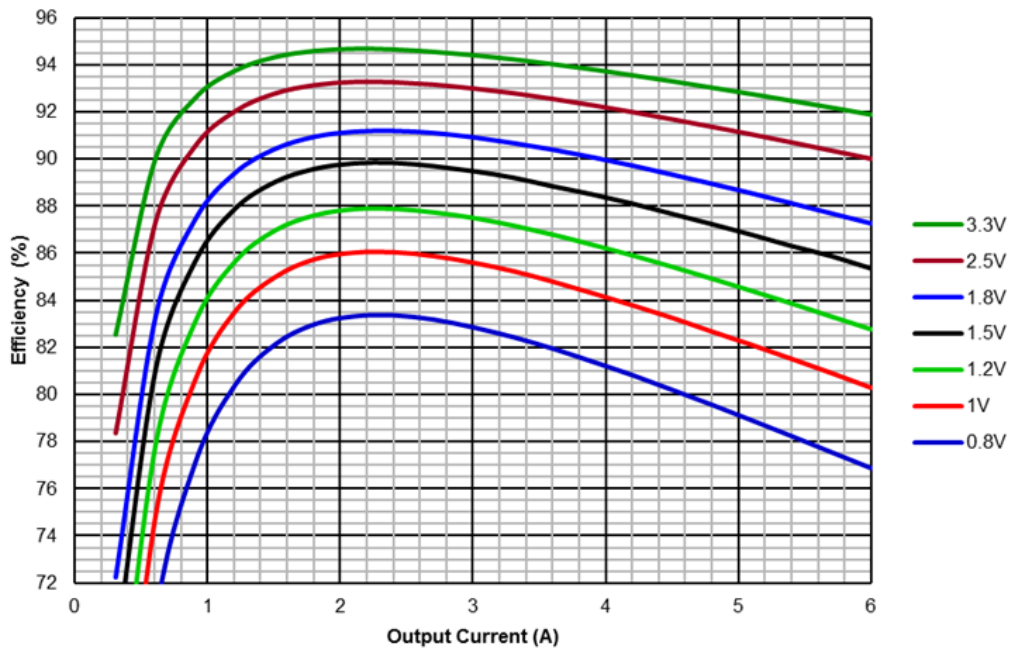

5.0 MECHANICAL OUTLINES AND PINOUT

Standard Gullwing Package Option:

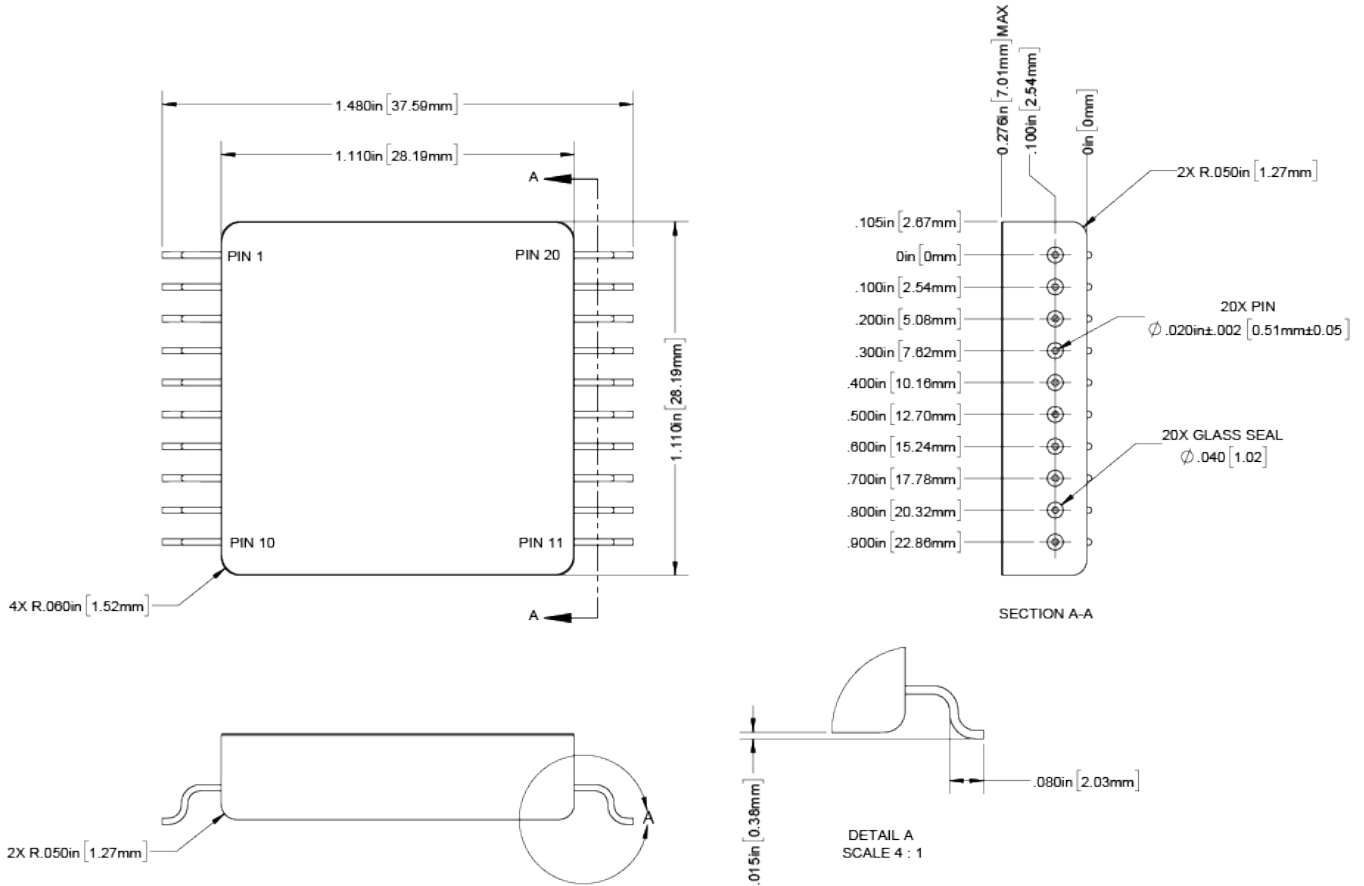

1. Tolerances are ± 0.005 " unless otherwise stated
2. Case temperature is measured on the center of the baseplate surface
3. Materials: Case (Steel, gold over nickel plated); Cover (Kovar, nickel plated); Pin (Copper-cored alloy 52, gold over nickel plated, 63/37 SnPb solder dipped); Pin Seals (Glass)

Pin	Function	Pin	Function	Pin	Function	Pin	Function
1	VIN	6	GND	11	AGND	16	GND
2	VIN	7	EN	12	TRIM	17	VOUT
3	VIN	8	M/S	13	+SENSE	18	VOUT
4	GND	9	SYNC	14	GND	19	VOUT
5	GND	10	PGOOD	15	GND	20	VOUT

5.0 MECHANICAL OUTLINES AND PINOUT (CONTINUED)

Optional Straight-Lead Package:

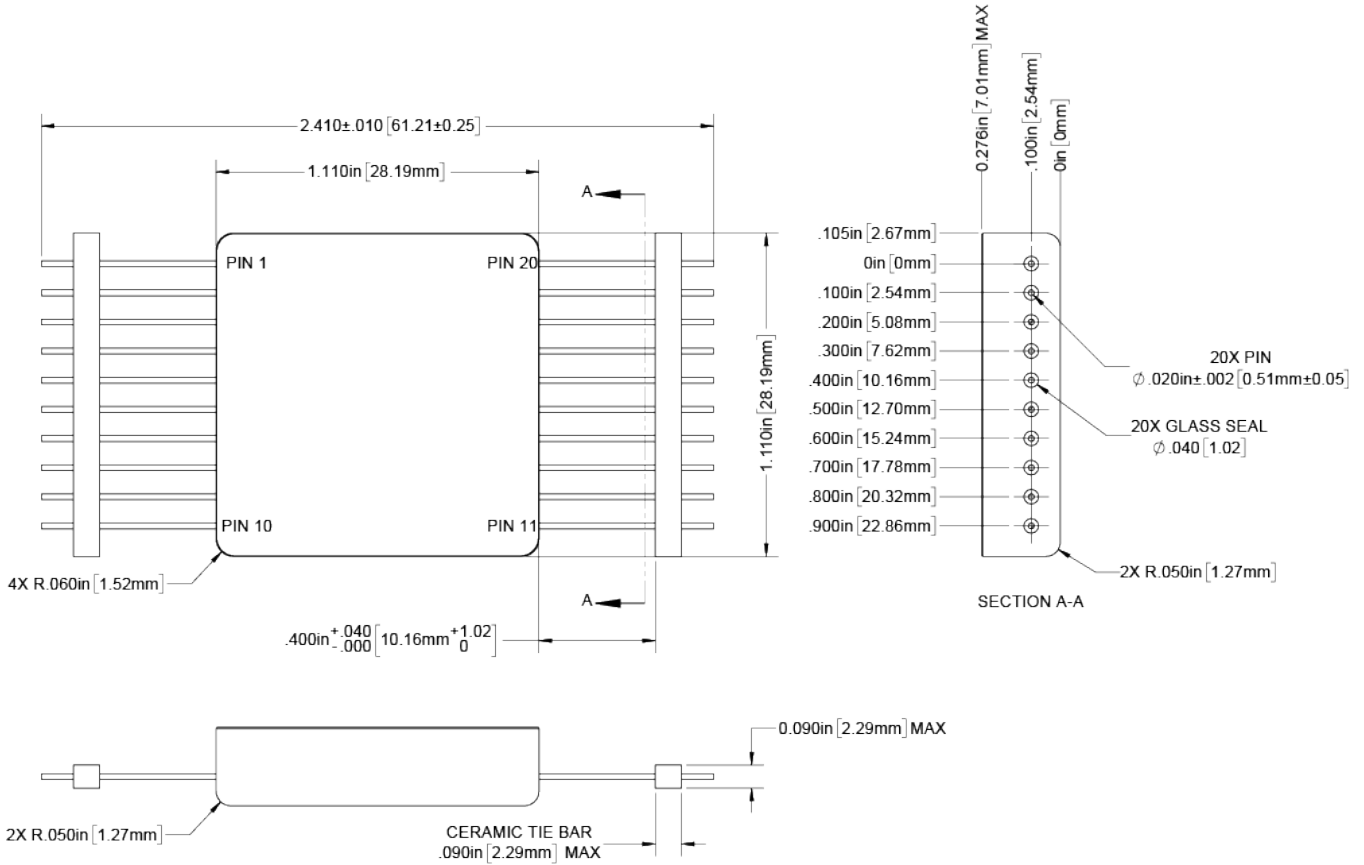

1. Tolerances are ± 0.005 " unless otherwise stated
2. Case temperature is measured on the center of the baseplate surface
3. Materials: Case (Steel, gold over nickel plated); Cover (Kovar, nickel plated); Pin (Copper-cored alloy 52, gold over nickel plated); Pin Seals (Glass)
4. Pins may have exposed nickel plating (not base metal) beyond the ceramic tie bars due to the plating process. No nickel plating is exposed between the tie bar and case.

Pin	Function	Pin	Function	Pin	Function	Pin	Function
1	VIN	6	GND	11	AGND	16	GND
2	VIN	7	EN	12	TRIM	17	VOUT
3	VIN	8	M/S	13	+SENSE	18	VOUT
4	GND	9	SYNC	14	GND	19	VOUT
5	GND	10	PGOOD	15	GND	20	VOUT

6.0 TECHNICAL NOTES



Please note that many of these functions are also demonstrated in detail on the VPT website in the form of [technical video labs](#).



6.1 GENERAL INFORMATION

6.1.1 Topology Description

The SVPL3R306SG is a non-isolated, fixed-frequency, radiation-hardened, synchronous buck converter based on the Intersil ISL70001ASEH. It is optimized for low voltage point-of-load (POL) applications. The SVPL3R306SG operates from a 3.1 to 5.5 V input and provides a stepped-down, precisely regulated, programmable output voltage at high efficiency.

6.1.2 Source Impedance

The impedance of the 3.3 V or 5 V source can interact with the POL converter and impact performance. High source impedance is often caused by a long input cable or other components added in series with the input. In some cases, additional input capacitance will be needed to stabilize the system.

6.1.3 Case Connection

The SVPL3R306SG case is connected to GND at a single point inside of the package.

6.2 FUNCTION DESCRIPTIONS

6.2.1 Enable (EN)

The figure below demonstrates the enable circuit. Initially, $V_{control}$ is below the turn-on threshold ($V_{control_enable}$), and the I_{en} current source is active. As $V_{control}$ rises, the turn-on threshold is calculated as:

$$V_{control_enable} = V_r \cdot \left[1 + \frac{R_1 + R_{en}}{R_2} \right] + I_{en} \cdot (R_1 + R_{en})$$

After $V_{control}$ reaches $V_{control_enable}$, I_{en} turns off. To disable the converter, drive $V_{control}$ below the turn-off threshold ($V_{control_disable}$):

$$V_{control_disable} = V_r \cdot \left[1 + \frac{R_1 + R_{en}}{R_2} \right]$$

The enable circuit hysteresis is:

$$V_{control_hys} = V_{control_enable} - V_{control_disable} = I_{en} \cdot (R_1 + R_{en})$$

When EN is driven directly from a low-resistance source, R_{en} can be assumed to be 0Ω , and the limits from the Performance Specifications table apply directly. To increase the turn-on threshold, add the appropriate R_{en} based on the equations above. If the ability to disable the SVPL3R306SG is not necessary, connect EN to VIN. When EN is below its turn-on threshold, the internal power MOSFETs are turned off, and the SVPL3R306SG power stage is in a high-impedance state.

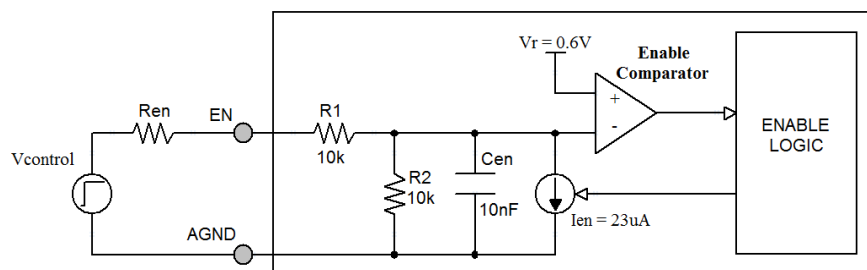

6.2.2 Power Good (PGOOD)

PGOOD is an open-drain output. It is pulled to GND when the output voltage is outside a $\pm 11\%$ regulation window. When the output voltage is within $\pm 11\%$ of its set point, PGOOD will be released. The PGOOD pin can be pulled up through an external resistor to any voltage from 0 to 5.5 V, independent of the input voltage. The external pull-up resistor should have a nominal value in the range of 1 k Ω to 10 k Ω .

6.2.3 Synchronization (M/S and SYNC)

When multiple DC/DC converters are connected to a common input bus, differences in their switching frequencies may lead to undesired beat frequencies at the common bus. The simplest way to mitigate beat frequency issues is to synchronize the POL converters.

To synchronize two or more SVPL3R306SG converters:

- Connect the M/S pin of the master converter to VIN (SYNC will output pulses with magnitude of VIN and 50% duty cycle)
- Connect the M/S pin of the slave converters to GND (SYNC will be configured as an input)
- Connect the SYNC pins of the master and slave converters together

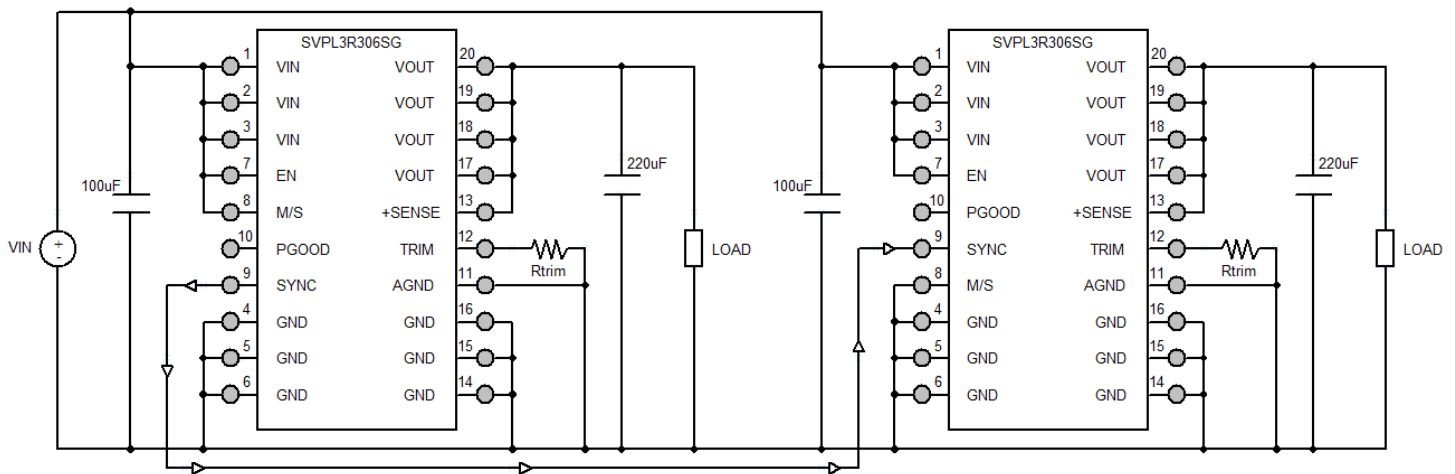

To synchronize to an external clock, connect M/S to GND and connect the clock output to SYNC. The clock signal's low level must be less than 1 V and its high level must be between 2.3 V and VIN to guarantee proper synchronization. Its duty cycle should be between 40 to 60%. If not synchronizing converters, connect M/S to VIN and leave SYNC open.

6.2.4 Adjusting the Output Voltage (TRIM)

The output voltage of the converter is set with an external trim resistor connected from the TRIM pin to the AGND pin. Use the equations or table below to choose the trim resistor value. Trim resistor tolerance of 0.1% is recommended to achieve an accurate output voltage. The default output voltage with the TRIM pin left open is 0.8 V. The designer can adjust the output voltage from 0.8 V to 85% of the input voltage.

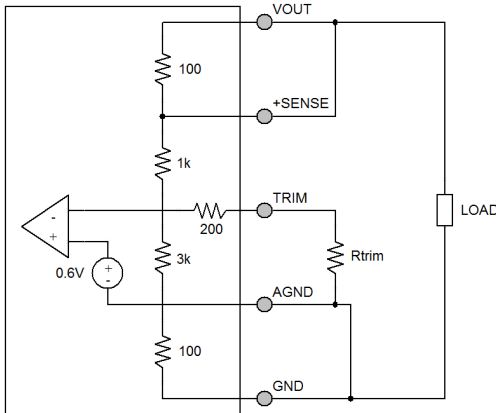

$$R_{trim} = \frac{600}{V_{OUT} - 0.8} - 200$$

$$V_{OUT} = \frac{600}{R_{TRIM} + 200} + 0.8$$

SVPL3R306SG	
+Vout (V)	Rtrim (Ω)
0.8	Open
0.9	5.80k
1.0	2.80k
1.2	1.30k
1.5	657
1.8	400
2.0	300
2.5	153
2.8	100
3.0	72.7
3.3	40.0
3.6	14.3
3.8	0.0

6.2.5 Output Capacitors

While the SVPL3R306SG is stable without external output capacitance, a minimum of 220 μF is required to meet the Performance Specifications from section 3.2. Output capacitors for point-of-load (POL) DC/DC converters should be chosen to meet output voltage ripple and transient requirements. Meeting the transient response requirement is accomplished by making the output impedance of the converter sufficiently small. Given the high control bandwidth of POL converters like the SVPL series, the peak output impedance is typically dominated by the equivalent series resistance (ESR) of the bulk output capacitance. Therefore, the output capacitors should be chosen to set a certain maximum total ESR. The total ESR is the parallel combination of the internal bulk capacitor's ESR and that of the added capacitors. Given the output voltage transient requirement, maximum load step, and the ESR of each bulk capacitor that will be added, the number of added capacitors needed is calculated with the following equations:

$$ESR_{TOTAL} = \frac{\Delta V_{OUT}}{\Delta I_{OUT}}$$

$$ESR_{ADDED} = \frac{ESR_{TOTAL} * ESR_{INTERNAL}}{ESR_{INTERNAL} - ESR_{TOTAL}}$$

$$N = \frac{ESR_{EACH}}{ESR_{ADDED}}$$

Parameter	Definition
ΔV _{OUT}	Max V _{OUT} transient allowed
ΔI _{OUT}	Max load current step
ESR _{TOTAL}	Total combined parallel ESR, including internal and added capacitors
ESR _{ADDED}	Combined parallel ESR of the added capacitors
ESR _{INTERNAL}	ESR of the internal bulk capacitor (43.7mΩ max under worst-case conditions)
ESR _{EACH}	ESR of each of the added capacitors
N	Number of added capacitors

Make sure that the added capacitance does not violate the maximum allowed output capacitance using the following equation:

$$C_{OUT-MAX} = \frac{3300\mu F}{V_{OUT}}$$

For example, assume that V_{OUT} is 1.5 V, the maximum output transient allowed is 37.5 mV, and the load step is 3 A. Assume the output capacitors being used are 330 μF and have a maximum ESR of 50mΩ each.

$$ESR_{TOTAL} = \frac{\Delta V_{OUT}}{\Delta I_{OUT}} = \frac{37.5mV}{3A} = 12.5m\Omega$$

$$ESR_{ADDED} = \frac{ESR_{TOTAL} * ESR_{INTERNAL}}{ESR_{INTERNAL} - ESR_{TOTAL}} = \frac{12.5m\Omega * 43.7m\Omega}{43.7m\Omega - 12.5m\Omega} = 17.5m\Omega$$

$$N = \frac{ESR_{EACH}}{ESR_{ADDED}} = \frac{50m\Omega}{17.5m\Omega} = 2.86 \rightarrow \text{use 3 output capacitors}$$

$$C_{OUT-MAX} = \frac{3300\mu F}{V_{OUT}} = \frac{3300\mu F}{1.5} = 2200\mu F$$

In the example, 3x 330 μ F/50 m Ω capacitors are needed. This is a total capacitance of 990 μ F, which is well below the 2200 μ F maximum allowed.

The output voltage ripple can be evaluated through simulation using the circuit below. This circuit incorporates worst-case conditions that include the effects of component tolerances, temperature extremes (-55 °C to 125 °C), radiation (100 krad), and aging (10 year mission). Note that the resistor shown in series with the inductor includes the resistance of the inductor and ISL70001A power FETs. The pulsed voltage source should have a peak voltage equal to the input voltage and the minimum switching frequency (850 kHz) to evaluate the worst-case ripple. The duty cycle should be adjusted to attain the correct output voltage.

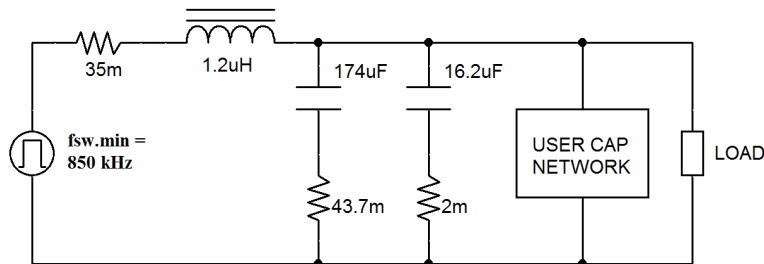

6.2.6 Input Capacitors

A minimum of 100 μ F of input capacitance should be added between VIN and GND to maintain the input voltage during transient conditions. The SVPL3R306SG has been designed with enough internal ceramic input capacitance to minimize the current stress through the added capacitors. For capacitances greater than 100 μ F, their RMS current will be determined primarily by their combined ESR. The left-hand graph below shows the total RMS current through the added input capacitors assuming worst-case conditions for load current, internal capacitance, switching frequency, input voltage, and output voltage. If multiple capacitors are added, then the RMS current will divide between them. The right-hand graph shows the power dissipation in the added input capacitors. Note that the RMS currents and maximum power dissipation under worst-case conditions are low enough that any practical input capacitors added are expected to have large margins over their ratings.

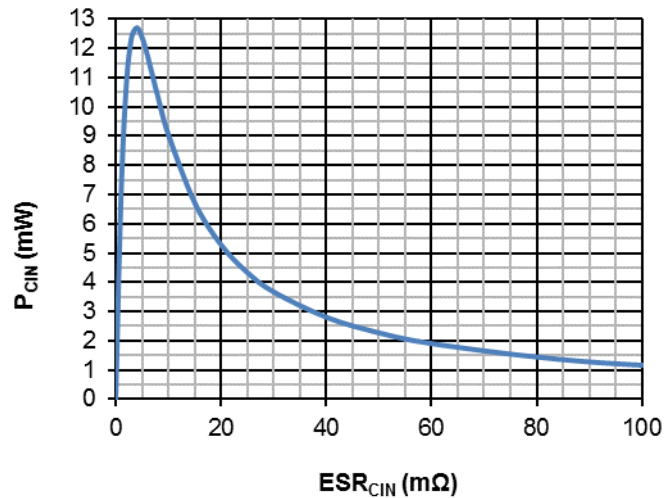
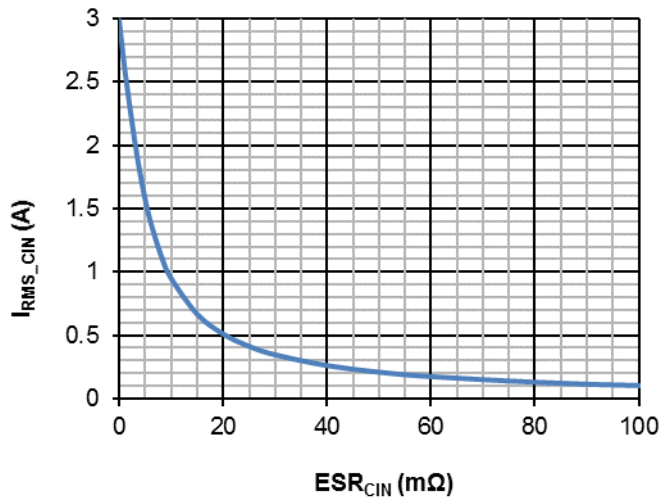

6.3 PROTECTION FEATURES

6.3.1 Input Undervoltage Lockout

The SVPL3R306SG Series provides input undervoltage lockout (UVLO) protection. For input voltages below the turn-on voltage, the converter will remain off. The internal power MOSFETs will be turned off, and the SVPL3R306SG power stage will be in a high-impedance state. When the input voltage exceeds the turn-on voltage, the converter will start. For input voltages above the UVLO turn-off voltage but below the operating range of the converter, the converter may reach its maximum duty cycle and the output may be out of regulation.

6.3.2 Output Soft-Start

The SVPL3R306SG Series utilizes an output soft-start function to ramp the output in a controlled manner, eliminating output voltage overshoot and limiting inrush current at turn on. A voltage mode soft-start ensures the output waveform remains consistent regardless of changes in the load current. The output rise time is approximately 4 ms. The soft-start function is active whether the module is turned on with an application of input voltage or from driving EN high. The turn-on delay time is specified from the application of input voltage (or application of EN) until the output reaches 90% of its final value.

6.3.3 Output Short Circuit Protection

The SVPL3R306SG Series provides hiccup-mode output short-circuit protection. When a sustained high peak current is detected, the converter will shut down. After a delay, the converter will attempt a soft-start. This sequence will continue until the fault is removed, allowing the converter to soft-start and resume normal operation.

6.4 THERMAL CONSIDERATIONS

The SVPL3R306SG is rated for full power operation at 125 °C. Above 125 °C, the output power must be derated linearly from full power at 125 °C to zero power at 135 °C. The operating temperature of the converter is specified on the baseplate of the converter. The converter is designed to be conduction-cooled, with the baseplate mounted to a heat sink, chassis, PCB, or other thermal surface. The internal power-dissipating components are mounted to the baseplate of the converter and all heat flow is through the baseplate. The lid of the converter does not provide a good thermal path.

The maximum temperature rise from junction to case is 10 °C at full load.

6.5 RADIATION HARDNESS ASSURANCE

VPT takes a conservative approach to radiation testing to ensure product performance in a space environment. VPT's DLA-approved Radiation Hardness Assurance (RHA) plan documents VPT's processes and procedures for guaranteeing the performance of VPT products under various environmental conditions in space including Total Ionizing Dose (TID) and Single-Event Effects (SEE). Additionally, Enhanced Low Dose-Rate Sensitivity (ELDRS) effects are considered for all bipolar ICs used in the hybrid. Hardness is guaranteed by a combination of both hybrid-level characterization and Radiation Lot Acceptance Testing (RLAT) of all sensitive semiconductor piece-parts used within the hybrid.

6.5.1 Radiation Test and Performance Levels

Radiation Environment		Piece Part RLAT	Hybrid-Level Characterization
Total Ionizing Dose (TID)	High Dose Rate (HDR)	100 krad(Si)	100 krad(Si)
	¹ Low Dose Rate (LDR)	50 krad(Si)	100 krad(Si)
² Single-Event Effects (SEE)	Destructive (SEB, SEGR, SEL)	Not applicable	≥ 85 MeV/mg/cm ²
	Non-Destructive (SET, SEU, SEFI)	Not applicable	≥ 85 MeV/mg/cm ²
³ Displacement Damage (DD)		1x10 ¹² n/cm ²	Not applicable

- The microcircuit device within the hybrid was characterized by its manufacturer to 150 krad(Si) at LDR and shown to be ELDRS free. Additionally, piece-part LDR radiation lot acceptance testing is performed to the level indicated.
- The microcircuit device within the hybrid was characterized by its manufacturer for destructive SEE. Non-destructive SEE was tested by VPT during hybrid level characterization.
- The microcircuit device was characterized per MIL-STD-883 Method 1017 to the level indicated. The device will be retested after design or process changes that may affect its RHA response.

6.5.2 RHA Plan Summary

Test	RHA Plan for SV Series Isolated DC-DC Converters
Total Ionizing Dose (TID):	Sensitive semiconductor components undergo RLAT to 100 krad(Si) per MIL-STD-883 Method 1019. Converters are characterized to 100 krad(Si).
Enhanced Low Dose Rate Sensitivity (ELDRS):	All bipolar linear ICs are characterized for ELDRS and tested in accordance with MIL-STD-883 test method 1019 section 3.13
Single Event Effects (SEE):	Converters are characterized to LET ≥ 85 MeV/mg/cm ² for both catastrophic events (SEL, SEB, SEGR) and functional interrupts (SEFI) under heavy ion exposure. Converters are also characterized for cross-section and magnitude of output transients (SET) for at least 3 different LET levels.
Radiation Lot Acceptance Testing (RLAT):	All production lots of sensitive semiconductor components undergo RLAT for TID at HDR and/or LDR as appropriate per part type.
Displacement Damage (DD):	The potentially sensitive microcircuit device is characterized to 1x10 ¹² n/cm ² per MIL-STD-883 Method 1017.

6.5.3 RHA Designators available on SMD

The SVPL3R306SG series converters are available on SMD with RHA level R. See section 8.0 for full SMD number information.

6.5.4 Supporting Documentation Available (Contact Sales)

- Radiation Hardness Assurance Plan: DLA-approved RHA plan covering TID, SEE, and ELDRS
- Worst-Case Analysis Report: Detailed worst-case analysis including electrical stress/derating limits and guaranteed circuit performance post-radiation and end of life
- Radiation Test Summary Report: Overview of piece-part RLAT and hybrid characterization for all guaranteed environments. Also includes SEE cross-section data.
- Reliability Report: MTBF report based on MIL-HDBK-217 reliability calculations.
- Thermal Analysis Report: Component temperature rise analysis and measurement results.

7.0 ENVIRONMENTAL SCREENING

100% tested per MIL-STD-883 as referenced to MIL-PRF-38534.

Contact sales for more information concerning additional environmental screening and testing options. VPT Inc. reserves the right to ship higher screened or SMD products to meet orders for lower screening levels at our sole discretion unless specifically forbidden by customer contract.

Test	MIL-STD-883 Test Method, Condition	/H+ (Class H + PIND)	/K (Class K)	/EM (Engineering Model) Non-QML ^{1,6}
Non-Destructive Bond Pull	TM2023	• ²	•	• ²
Internal Visual	TM2010, TM2017, TM2032 (MIL-STD-750, TM2072, TM2073)	•	•	•
Temperature Cycling	TM1010, Condition C -65 °C to 150 °C, Ambient	•	•	
Constant Acceleration	TM2001, 3000g, Y1 Direction	•	•	
PIND ³	TM2020, Condition A	• ²	•	
Pre Burn-In Electrical	25 °C		•	
Burn-In	TM1015, 320 hrs., 125 °C, Case Typ		•	
	TM1015, 160 hrs., 125 °C, Case Typ	•		
Final Electrical	24 hrs., 125 °C, Case Typ			•
	MIL-PRF-38534, Group A Subgroups 1-6 -55 °C, 25 °C, 125 °C ⁴	•	•	
Hermeticity (Seal)	MIL-PRF-38534, Group A Subgroups 1 and 4 25 °C			•
	TM1014, Fine Leak, Condition A2 or B1	•	•	
Radiography ⁵	TM1014, Gross Leak, Condition C1 or B2	•	•	
	Gross Leak, Dip (1x10 ⁻³)			•
External Visual	TM2009	•	•	•

1. Non-QML products may not meet all requirements of MIL-PRF-38534
2. Not required per MIL-PRF-38534. Test performed for additional product quality assurance
3. PIND test Certificate of Compliance included in product shipment
4. 100% R&R testing with all test data included in product shipment
5. Radiographic test Certificate of Compliance and film(s) or data CD included in product shipment
6. Engineering models utilize only the screening specified and are not considered compliant for flight use

8.0 STANDARD MICROCIRCUIT DRAWING (SMD) NUMBERS

Standard Microcircuit Drawing Number	SVPL3R306SG Series Similar Part Number
5962R1721501HYC	SVPL3R306SGN/H+
5962R1721501HXA	SVPL3R306SG/H+-E
5962R1721501KYC	SVPL3R306SGN/K
5962R1721501KXA	SVPL3R306SG/K-E

Do not use the SVPL3R306SG Series similar part number for SMD product acquisition. It is listed for reference only. For exact specifications of the SMD product, refer to the SMD drawing. SMDs can be downloaded from the DLA Land and Maritime (Previously known as DSCC) website at <https://landandmaritimeapps.dla.mil/programs/defaultapps.asp>. The SMD numbers listed above represents the Federal Stock Class, Device Type, Device Class Designator, Case Outline, Lead Finish and RHA Designator (where applicable). Please reference the SMD for other screening levels, lead finishes, and radiation levels. All SMD products are marked with a "Q" on the cover as specified by the QML certification mark requirement of MIL-PRF-38534.

9.0 ORDERING INFORMATION

SVPL	3R3	06	S	G	/K	-	E
1	2	3	4	5	6	7	8

(1) Product Series	(2) Nominal Input Voltage	(3) Output Current	(4) Number of Outputs	(5) Package Option	(6) Package Lead Option ⁴	(7) Screening Code ^{1,2,3}	(8) Additional Screening Code ⁴
SVPL	3R3 3.3 Volts	06 6 Amps	S Single	G Gullwing	None Formed Straight	/EM Engineering Model /H+ Class H + PIND /K Class K	E Solder Dipped Contact Sales for additional options

- 1 Contact the VPT Sales Department for availability of Class H (/H) or Class K (/K) qualified products
- 2 VPT Inc. reserves the right to ship higher screened or SMD products to meet lower screened orders at our sole discretion unless specifically forbidden by customer contract
- 3 Engineering models utilize only the standard screening specified and are not considered compliant for flight use. These models are intended for low volume engineering characterization only and have no guarantee regarding operation in a radiation environment. The customer must place the following statement on each line item of their purchase order(s) for /EM units when ordering engineering models:

“(Customer Name) acknowledges that the /EM unit listed in this line item is not permitted for flight use and will be used for Engineering characterization only.”
- 4 When selecting Package Lead Option “Formed”, Additional Screening Code “-E” (solder dipped leads) must also be applied. When selecting Package Lead Option “Straight”, Additional Screening Code “-E” should not be applied.

Please contact your sales representative or the VPT Inc. Sales Department for more information concerning additional environmental screening and testing, different input voltage, output voltage, power requirements, source inspection, and/or special element evaluation for space or other higher quality applications.

10.0 CONTACT INFORMATION

To request a quotation or place orders please contact your sales representative or the VPT, Inc. Sales Department at:

Phone: (425) 353-3010
Fax: (425) 353-4030
E-mail: vptsales@vptpower.com

All information contained in this datasheet is believed to be accurate, however, no responsibility is assumed for possible errors or omissions. The products or specifications contained herein are subject to change without notice.

11.0 ADDITIONAL INFORMATION

Visit the VPT website for additional technical resources, including:

[Product Catalogs](#)



[Application Notes and White Papers](#)

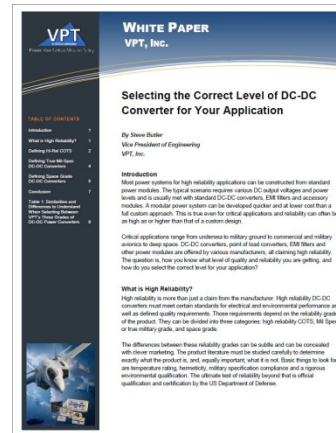

[Technical Video Labs](#)



[Additional Products For Avionics/Military, Hi-Rel COTS, and Space Applications](#)

