

Features and Benefits

- Low voltage supply : from 2.5V to 5.5V
- Chopper-stabilized amplifier stage
- Low power switch: 2.1mA
- Optimized ESD performance: 6kV
- Designed for standalone PCB applications
- Thin SOT23 3L Green Compliant package

Application Examples

- Consumer and Industrial
- BLDC motor commutation
- Solid-state Latch
- Low power applications
- Index counting

Ordering Information

Product Code	Temperature Code	Package Code	Option code	Packing form code
MLX92214	L	SE	AAA-000	RE
MLX92214	K	SE	AAA-000	RE

Legend:

Temperature code: L (-40 to 150°C)
 K (-40 to 125°C)
 Package Code: SE = TSOT-23L
 Packing Form: RE = Reel
 Ordering code AAA = Very sensitive latch
 Ordering Example: MLX92214LSE-AAA-000

1. Functional Diagram

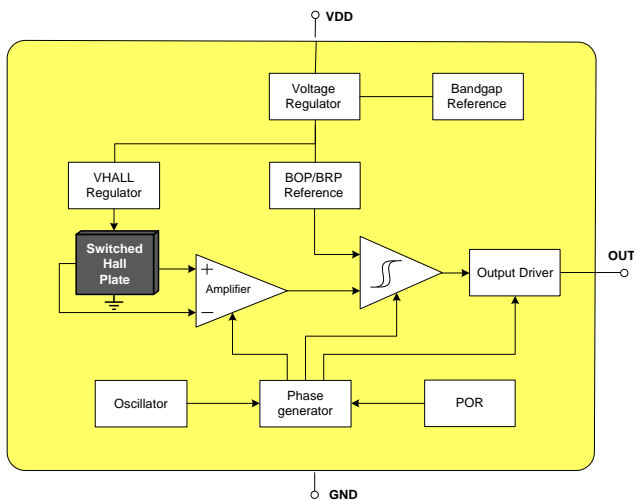

2. General Description

The Melexis MLX92214 is a low voltage Hall-effect switch designed in mixed signal CMOS technology. The device integrates a voltage regulator, Hall sensor with advanced offset cancellation system and an open-drain output driver, all in a single package and qualified according AEC-Q100.

The device features a low voltage regulator with optimized performances targeting low power consumption at low voltage levels.

It is suitable for use in automotive applications thanks to its wide temperature range and extensive qualification according to automotive standards.

The MLX92214 is delivered in a Green compliant 3-pin Thin Small Outline Transistor (TSOT) for surface-mount process.

Table of Contents

1. Functional Diagram	1
2. General Description	1
3. Glossary of Terms	3
4. Absolute Maximum Ratings	3
5. General Electrical Specifications	4
6. Magnetic Specification	5
6.1. MLX92214LSE-AAA-000-RE	5
6.2. MLX92214KSE-AAA-000-RE	5
7. Output behaviour versus Magnetic Field	6
7.1. Latch sensor: MLX92214xSE-AAA-000	6
8. Detailed General Description	7
9. Latch/Switch characteristics	7
10. Performance graphs	8
10.1. MLX92214xSE -AAA-000	8
11. Application Information	8
11.1. Typical Three-Wire Application Circuit	8
12. Standard information regarding manufacturability of Melexis products with different soldering processes	9
13. ESD Precautions	9
14. Package Information	10
14.1. SE (TSOT-3L) Package Information	10
15. Contact	11
16. Disclaimer	11

3. Glossary of Terms

MilliTesla (mT), Gauss	Units of magnetic flux density: 1mT = 10 Gauss
RoHS	Restriction of Hazardous Substances
TSOT	Thin Small Outline Transistor (TSOT package) – also referred with the Melexis package code “SE”
ESD	Electro-Static Discharge
BLDC	Brush-Less Direct-Current

4. Absolute Maximum Ratings

Parameter	Symbol	Value	Units
Supply Voltage	V_{DD}	-0.5 to 6	V
Supply Current ⁽¹⁾	I_{DD}	± 20	mA
Output Voltage	V_{OUT}	-0.5 to 6	V
Output Current ⁽¹⁾	I_{OUT}	± 20	mA
Operating Temperature Range for MLX92214LSE	T_A	-40 to 150	°C
Operating Temperature Range for MLX92214KSE	T_A	-40 to 125	°C
Storage Temperature Range	T_S	-50 to 165	°C
Maximum Junction Temperature	T_J	165	°C
ESD Sensitivity – HBM ⁽²⁾	-	6000	V
ESD Sensitivity – CDM	-	500	V

Table 1: Absolute maximum ratings

Exceeding the absolute maximum ratings may cause permanent damage. Exposure to absolute-maximum-rated conditions for extended periods may affect device reliability.

¹ Including current through the protection structure. Max Power dissipation should be also considered.

² Human Body Model according AEC-Q100-002 standard

5. General Electrical Specifications

DC Operating Parameters $T_A = -40$ to 150°C ⁽¹⁾, $V_{DD} = 2.5\text{V}$ to 5.5V (unless otherwise specified)

Parameter	Symbol	Test Conditions	Min	Typ	Max	Units
Supply Voltage	V_{DD}	Operating	2.5		5.5	V
Supply Current	I_{DD}		1.0	2.1	3.5	mA
Output Saturation Voltage	V_{DSON}	$I_{OUT} = 5\text{mA}$, $B > B_{OP}$			0.5	V
Output Leakage Current	I_{OFF}	$B < B_{RP}$, $V_{OUT} = 5.5\text{V}$		0.01	10	μA
Output Rise Time ⁽²⁾	t_r	$R_L = 1\text{k}\Omega$, $C_L = 50\text{pF}$		0.25		μs
Output Fall Time ⁽²⁾	t_f	$R_L = 1\text{k}\Omega$, $C_L = 50\text{pF}$		0.25		μs
Power-On Time ⁽³⁾	t_{PON}	$dV_{DD}/dt > 2\text{V}/\mu\text{s}$		38	70	μs
Power-On Reset Voltage ⁽⁴⁾	V_{POR}			1.95	2.1	V
Power-On State	-		High			-
Maximum Switching Frequency ⁽²⁾	F_{SW}	$B \geq \pm 40\text{mT}$ and square wave magnetic field	10			KHz
SE Package Thermal Resistance	R_{TH}	Single layer (1S) Jeduc board		300		$^{\circ}\text{C}/\text{W}$

Table 2: Electrical specifications

¹ Maximum $T_A = 125^{\circ}\text{C}$ in case MLX92214KSE-AAA-000

² Guaranteed by design and verified by characterization, not production tested

³ The Power-On time represents the time from reaching $V_{DD} = 2.5\text{V}$ to the first refresh of the output.

⁴ If V_{DD} drops below V_{POR} the output is reset to High state.

6. Magnetic Specification

6.1. MLX92214LSE-AAA-000-RE

DC Operating Parameters $T_A = -40$ upto 150 °C, $V_{DD} = 2.5V$ to $5.5V$ (unless otherwise specified)

Parameter	Symbol	Test Conditions	Min	Typ	Max	Units
Operating Point	B_{OP}	$T_A = -40^\circ C$	0.5	2.1	4.0	mT
		$T_A = 25^\circ C$	0.5	2.0	4.0	mT
		$T_A = 150^\circ C$	0.5	1.9	4.0	mT
Release Point	B_{RP}	$T_A = -40^\circ C$	-4.0	-2.1	-0.5	mT
		$T_A = 25^\circ C$	-4.0	-2.0	-0.5	mT
		$T_A = 150^\circ C$	-4.0	-1.9	-0.5	mT
Hysteresis	B_{HYST}	$T_A = -40^\circ C$	1.7	4.2	6.8	mT
		$T_A = 25^\circ C$	1.7	4	6.8	mT
		$T_A = 150^\circ C$	1.7	3.8	6.8	mT

Table 3: Magnetic specifications

6.2. MLX92214KSE-AAA-000-RE

DC Operating Parameters $T_A = -40$ upto 125 °C, $V_{DD} = 2.5V$ to $5.5V$ (unless otherwise specified)

Parameter	Symbol	Test Conditions	Min	Typ	Max	Units
Operating Point	B_{OP}	$T_A = -40^\circ C$	0.5	2.1	4.0	mT
		$T_A = 25^\circ C$	0.5	2.0	4.0	mT
		$T_A = 125^\circ C$	0.5	1.9	4.0	mT
Release Point	B_{RP}	$T_A = -40^\circ C$	-4.0	-2.1	-0.5	mT
		$T_A = 25^\circ C$	-4.0	-2.0	-0.5	mT
		$T_A = 125^\circ C$	-4.0	-1.9	-0.5	mT
Hysteresis	B_{HYST}	$T_A = -40^\circ C$	1.7	4.2	6.8	mT
		$T_A = 25^\circ C$	1.7	4	6.8	mT
		$T_A = 125^\circ C$	1.7	3.8	6.8	mT

Table 4: Magnetic specifications

7. Output behaviour versus Magnetic Field

7.1. Latch sensor: MLX92214xSE-AAA-000

Parameter	Test Conditions	OUT
South pole	$B > B_{OP}$	Low
North pole	$B < B_{RP}$	High

Table 5: Output behaviour versus magnetic pole ⁽¹⁾

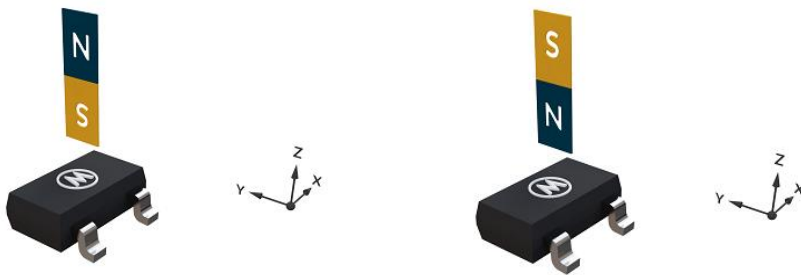

¹ Magnetic pole facing the branded / top side of the package

8. Detailed General Description

Based on mixed signal CMOS technology, MLX92214 is a Hall-effect device with very high magnetic sensitivity allowing the use of generic magnets, weak magnets or larger air gap.

The chopper-stabilized amplifier uses switched capacitor techniques to suppress the offset generally observed with Hall sensors and amplifiers. The CMOS technology makes this advanced technique possible and contributes to smaller chip size and lower current consumption than bipolar technology. The small chip size is also an important factor to minimize the effect of physical stress.

This combination results in more stable magnetic characteristics and enables faster and more precise design.

The operating voltage from 2.5V to 5.5V, low current consumption and large choice of operating temperature range according to "L" specification make this device suitable for automotive, industrial and consumer low voltage applications.

The output signal is open-drain type. Such output allows simple connectivity with TTL or CMOS logic by using a pull-up resistor tied between a pull-up voltage and the device output

9. Latch/Switch characteristics

The MLX92214-AAA exhibits magnetic latching characteristics.

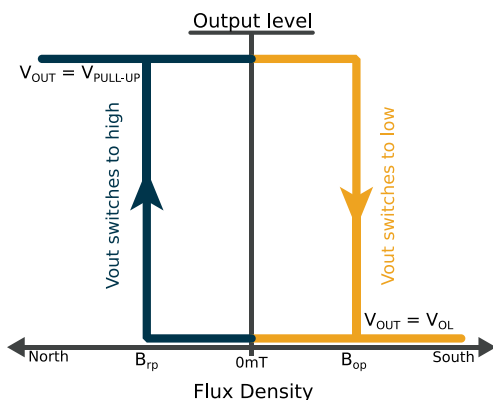

Typically, the device behaves as a latch with symmetric operating and release switching points ($B_{OP} = |B_{RP}|$). This means magnetic fields with equivalent strength and opposite direction drive the output high and low.

Removing the magnetic field ($B \rightarrow 0$) keeps the output in its previous state. This latching property defines the device as a magnetic memory.

10. Performance graphs

10.1. MLX92214xSE -AAA-000

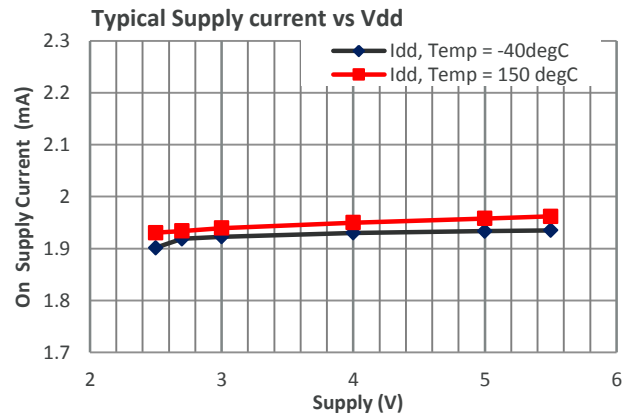
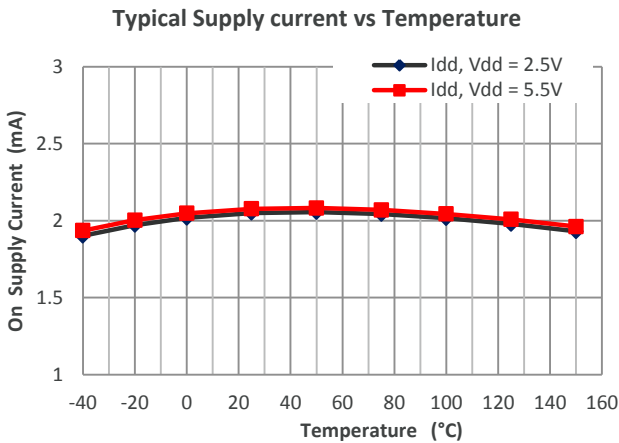
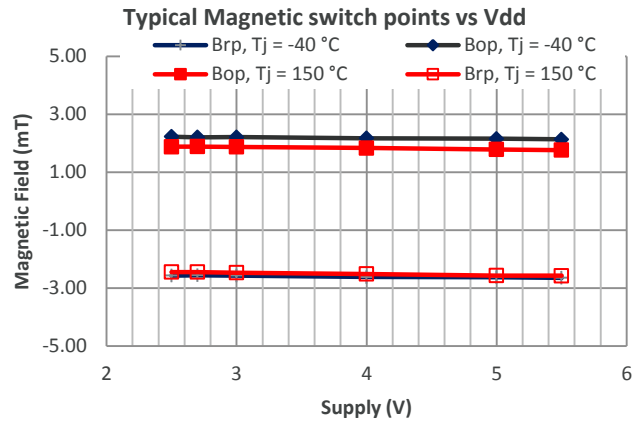
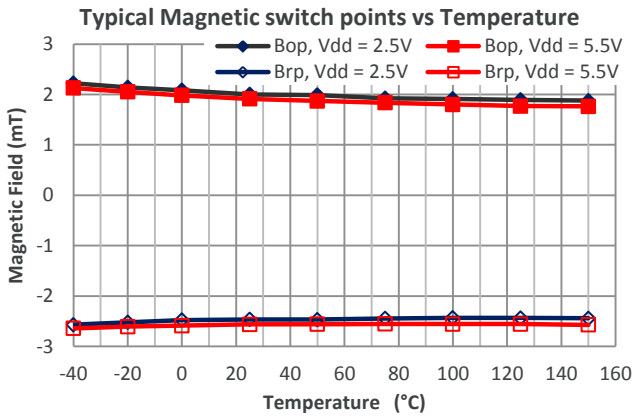

11. Application Information

11.1. Typical Three-Wire Application Circuit

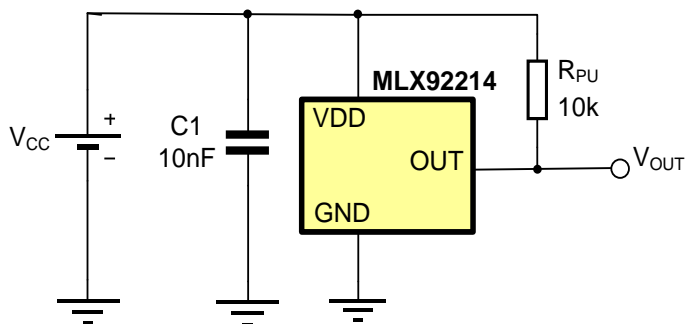

Notes:

1. For proper operation, a 10nF to 100nF bypass capacitor should be placed as close as possible to the V_{DD} and ground pin.
2. A capacitor connected to the output is not obligatory, because the output slope is generated internally.

12. Standard information regarding manufacturability of Melexis products with different soldering processes

Our products are classified and qualified regarding soldering technology, solderability and moisture sensitivity level according to following test methods:

Reflow Soldering SMD's (Surface Mount Devices)

- IPC/JEDEC J-STD-020
Moisture/Reflow Sensitivity Classification for Nonhermetic Solid State Surface Mount Devices (classification reflow profiles according to table 5-2)
- EIA/JEDEC JESD22-A113
Preconditioning of Nonhermetic Surface Mount Devices Prior to Reliability Testing (reflow profiles according to table 2)

Wave Soldering SMD's (Surface Mount Devices) and THD's (Through Hole Devices)

- EN60749-20
Resistance of plastic- encapsulated SMD's to combined effect of moisture and soldering heat
- EIA/JEDEC JESD22-B106 and EN60749-15
Resistance to soldering temperature for through-hole mounted devices

Iron Soldering THD's (Through Hole Devices)

- EN60749-15
Resistance to soldering temperature for through-hole mounted devices

Solderability SMD's (Surface Mount Devices) and THD's (Through Hole Devices)

- EIA/JEDEC JESD22-B102 and EN60749-21
Solderability

For all soldering technologies deviating from above mentioned standard conditions (regarding peak temperature, temperature gradient, temperature profile etc) additional classification and qualification tests have to be agreed upon with Melexis.

The application of Wave Soldering for SMD's is allowed only after consulting Melexis regarding assurance of adhesive strength between device and board.

Melexis recommends reviewing on our web site the General Guidelines [soldering recommendation](http://www.melexis.com/Quality_soldering.aspx) (http://www.melexis.com/Quality_soldering.aspx) as well as [trim&form recommendations](http://www.melexis.com/Assets/Trim-and-form-recommendations-5565.aspx) (<http://www.melexis.com/Assets/Trim-and-form-recommendations-5565.aspx>).

Melexis is contributing to global environmental conservation by promoting **lead free** solutions. For more information on qualifications of **RoHS** compliant products (RoHS = European directive on the Restriction Of the use of certain Hazardous Substances) please visit the quality page on our website: <http://www.melexis.com/quality.aspx>

13. ESD Precautions

Electronic semiconductor products are sensitive to Electro Static Discharge (ESD). Always observe Electro Static Discharge control procedures whenever handling semiconductor products.

14. Package Information

14.1. SE (TSOT-3L) Package Information

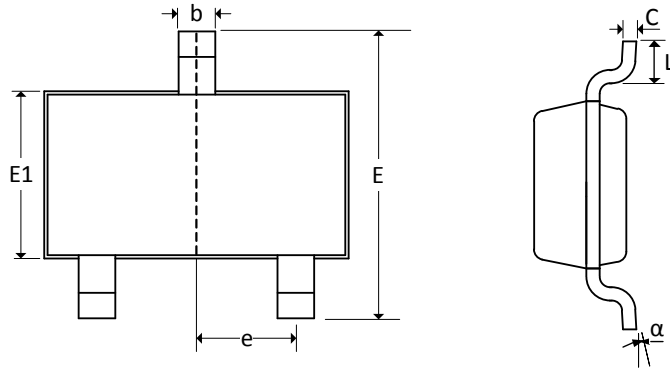

Notes:

1. All dimensions are in millimeters
2. Outermost plastic extreme width does not include mold flash or protrusions. Mold flash and protrusions shall not exceed 0.15mm per side.
3. Outermost plastic extreme length does not include mold flash or protrusions. Mold flash and protrusions shall not exceed 0.25mm per side.
4. The lead width dimension does not include dambar protrusion. Allowable dambar protrusion shall be 0.07mm total in excess of the lead width dimension at maximum material condition.
5. Dimension is the length of terminal for soldering to a substrate.
6. Formed lead shall be planar with respect to one another with 0.076mm at seating plane.

Marking:

Top side : MLX92214KSE-AAA-000 = 4KYY (YY = year code)

MLX92214LSE-AAA-000 = 4LYY (YY = year code)

Bottom side: LLLL= last 4 digits from lot#

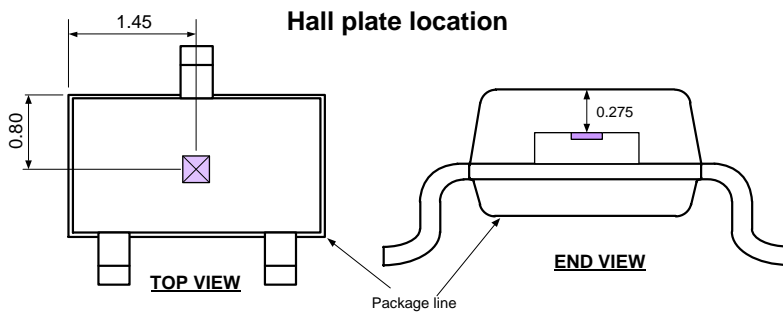
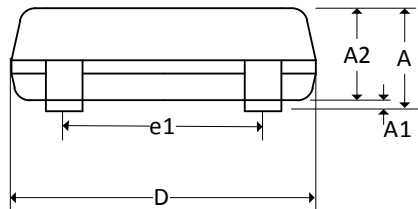

	A	A1	A2	D	E	E1	L	b	c	e	e1	α
min	–	0.025	0.85	2.80	2.60	1.50	0.30	0.30	0.10	0.95	1.90	0°
max	1.00	0.10	0.90	3.00	3.00	1.70	0.50	0.45	0.20	BSC	BSC	8°

Table 5: Package dimensions

Pin No	Name	Type	Function
1	VDD	Supply	Supply Voltage
2	OUT	Output	Open Drain
3	GND	Ground	Ground pin

Table 6: Package pinout

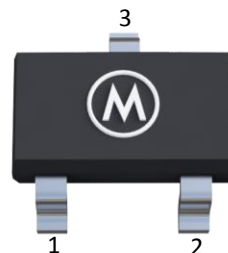

15. Contact

For the latest version of this document, go to our website at www.melexis.com.

For additional information, please contact our Direct Sales team and get help for your specific needs:

Europe, Africa	Telephone: +32 13 67 04 95
	Email : sales_europe@melexis.com
Americas	Telephone: +1 603 223 2362
	Email : sales_usa@melexis.com
Asia	Email : sales_asia@melexis.com

16. Disclaimer

The information furnished by Melexis herein ("Information") is believed to be correct and accurate. Melexis disclaims (i) any and all liability in connection with or arising out of the furnishing, performance or use of the technical data or use of the product(s) as described herein ("Product") (ii) any and all liability, including without limitation, special, consequential or incidental damages, and (iii) any and all warranties, express, statutory, implied, or by description, including warranties of fitness for particular purpose, non-infringement and merchantability. No obligation or liability shall arise or flow out of Melexis' rendering of technical or other services.

The Information is provided "as is" and Melexis reserves the right to change the Information at any time and without notice. Therefore, before placing orders and/or prior to designing the Product into a system, users or any third party should obtain the latest version of the relevant information to verify that the information being relied upon is current.

Users or any third party must further determine the suitability of the Product for its application, including the level of reliability required and determine whether it is fit for a particular purpose.

The Information is proprietary and/or confidential information of Melexis and the use thereof or anything described by the Information does not grant, explicitly or implicitly, to any party any patent rights, licenses, or any other intellectual property rights.

This document as well as the Product(s) may be subject to export control regulations. Please be aware that export might require a prior authorization from competent authorities.

The Product(s) are intended for use in normal commercial applications. Unless otherwise agreed upon in writing, the Product(s) are not designed, authorized or warranted to be suitable in applications requiring extended temperature range and/or unusual environmental requirements. High reliability applications, such as medical life-support or life-sustaining equipment are specifically not recommended by Melexis.

The Product(s) may not be used for the following applications subject to export control regulations: the development, production, processing, operation, maintenance, storage, recognition or proliferation of 1) chemical, biological or nuclear weapons, or for the development, production, maintenance or storage of missiles for such weapons; 2) civil firearms, including spare parts or ammunition for such arms; 3) defense related products, or other material for military use or for law enforcement; 4) any applications that, alone or in combination with other goods, substances or organisms could cause serious harm to persons or goods and that can be used as a means of violence in an armed conflict or any similar violent situation.

The Products sold by Melexis are subject to the terms and conditions as specified in the Terms of Sale, which can be found at <https://www.melexis.com/en/legal/terms-and-conditions>.

This document supersedes and replaces all prior information regarding the Product(s) and/or previous versions of this document.

Melexis NV © - No part of this document may be reproduced without the prior written consent of Melexis.

ISO/TS 16949 and ISO14001 Certified