

### DESCRIPTION

PMF8300 is Posifa Technologies' next-generation of mass air flow sensors for respiratory care and other medical and instrumentation applications. Compared to our previous generation solution, the PMF8300 Series offers improved accuracy, repeatability, and signal-to-noise performance.



The PMF8300 series features Posifa's third-generation thermal flow die, benefiting from the latest innovations in microfabrication. The sensor die uses a pair of thermopiles to detect changes in temperature gradient caused by mass flow, delivering excellent signal-to-noise, and repeatability. The "solid state" thermal isolation structure eliminates the need for the surface cavity or fragile membrane used in competing technologies. The sensor die, with its silicon carbide protective film, is robust against water condensation while allowing the highest level of sensitivity and minimizing the cost of packaging.

The PMF8300 sensors provide both analog (voltage) and digital I2C outputs.

### APPLICATIONS

- Oxygen concentrators
- Respirators and ventilators
- Nebulizers
- CPAP equipment
- Anesthesia delivery
- Environmental monitoring
- Fuel cell control

### FEATURES

- Compact footprint
- Extremely fast response time (< 5 ms)
- Resistant to condensed water and dust particles
- Long-term stability
- Bidirectional flow sensing (optional)
- Analog and I<sup>2</sup>C, Linear output

### MAXIMUM RATINGS

- Operating Temperature: -40°C to 85°C
- Storage Temperature: -40°C to 85°C
- Over Pressure: 50 psi

## SPECIFICATIONS

Test Conditions: $V_{in}=5\pm 0.01VDC$ , $T_a=22^{\circ}C$ .					
SPECIFICATIONS	MIN	TYP	MAX	UNIT	CONDITIONS
PMF8315		15		SLM	
PMF8320		20		SLM	
PMF8350		50		SLM	
PMF8399		100		SLM	
Output Count (Digital)	6553 to 58981			count	
Null Count (Digital)	5898		7208	count	
Output (Analog)	0.5 to 4.5			VDC	
Null Output (Analog)	0.45		0.55	VDC	
Flow Repeatability		0.5		% F.S.	
Flow Response Time <sup>2</sup>		5		ms	
Warm Up Time			5	sec	
Over Pressure	50			psi	
Operating Temperature	-40		85	$^{\circ}C$	
Supply Voltage		5		VDC	We recommend using 1% voltage regulator
Supply Current		20		mA	at 5 VDC supply
Wetted Materials	Nylon, Silicon Oxide, FR4 and Epoxy				

Notes:

1. SLM: standard liter per minute. Standard conditions:  $0^{\circ}C$  and 1 atmosphere. Also known as NLPM (nominal liter per minute).
2. 10% to 90% rise time of the flow sensor to electrically respond to any mass flow change. May be affected by the pneumatic interface.

## OUTPUT DESCRIPTION

### For **PMF8300 Analog Output**

Flow Rate =  $[(V_{out} - 0.5 V) / 4 V] \times \text{Full Scale Flow Rate}$

For example, for PMF8350 full scale flow rate is 50 SLM. When  $V_{out}$  reads 3.5 V, the Flow Rate is:  $[(3.5 V - 0.5 V) / 4 V] \times 50 \text{ SLM} = 37.5 \text{ SLM}$

### For **PMF8300 Digital Output**

Flow Rate =  $[(\text{Count} - 6553) / 52428] \times \text{Full Scale Flow Rate}$

For example, for PMF8350 full scale rate is 50 SLM. When digital output reads 10000, the Flow Rate is:

$[(10000 - 6553) / 52428] \times 50 \text{ SLM} = 3.28 \text{ SLM}$

\*Contact Posifa for I<sup>2</sup>C Communication app note.

## PACKAGE DIMENSIONS

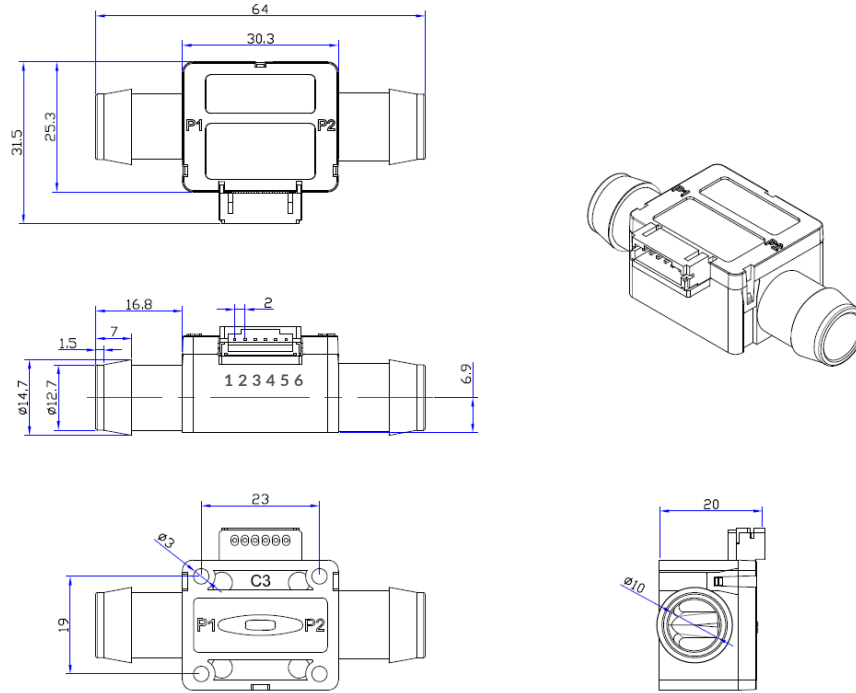

Contact Posifa for sensor CAD model.

Pin#	Description
1	VDD
2	GND
3	Out
4	SDA
5	SCL
6	N/C

## ORDERING INFORMATION

<b>PART NUMBER</b>	<b>SPECIFICATIONS</b>
PMF8315	15 SLM, voltge and digital I2C output, Linear
PMF8320	20 SLM, voltge and digital I2C output, Linear
PMF8350	50 SLM, voltge and digital I2C output, Linear
PMF8399	100 SLM, voltge and digital I2C output, Linear

### EUROPEAN DISTRIBUTOR

BS-rep GmbH

Eichertstr. 68, D-56745 Weibern, Germany

Tel: +49 (0) 2655 / 96 26 476

Email: info@sensor-rep.de