

## General Description

EZ-PD™ CCG6DF and EZ-PD CCG6SF are dual-port and single-port USB Type-C controllers that comply with the latest USB Type-C and PD specifications. These devices provide a complete USB Type-C and USB-Power Delivery port control solution for PCs and notebooks. Both of these devices include a VBUS provider path load switch. These devices also contain a True Random Number Generator for authentication, a 32-bit, 48-MHz Arm® Cortex®-M0 processor with 64-KB flash and 96-KB ROM, integrating a complete Type-C Transceiver including the Type-C termination resistors Rp, Rd, and dead battery Rd termination. CCG6DF is available in a 96-ball BGA package, whereas CCG6SF is available in 96-ball BGA and 48-pin QFN packages.

## Applications

- Notebooks and desktops
- Thunderbolt hosts, non-Thunderbolt hosts

## Features

### USB-PD

- Supports latest USB PD 3.0 specification
- Fast Role Swap (FRS)
- Extended Data Messaging

### Type-C

- Integrated current sources for DFP<sup>[1]</sup> role (Rp)
  - Default current at 900 mA
  - 1.5 A
  - 3 A
- Integrated Rd resistor for UFP<sup>[2]</sup> role
- Integrated VCONN FETs to power EMCA cables
- Integrated dead battery termination
- Integrated high-voltage protection on CC and SBU pins to protect against accidental shorts to the VBUS pin on the Type-C connector
- Integrated pass through SBU Switch for 20-V protection

### Mux

- Integrated USB 2.0 Analog Mux for USB 2.0 HS and UART data

### Integrated Provider VBUS Load Switch

- VBUS Provider Switch (5 V/3A)
- Slew rate controlled turn-on on the VBUS provider path, tolerant to 24 V
- Configurable hardware-controlled VBUS overvoltage, under-voltage, overcurrent, short circuit, reverse current protection, and thermal shutdown
- VBUS high-side current sense amplifier capable of measuring current across 5-mΩ series resistance on the provider path

- In response to Fast Role Swap request, turns OFF external consumer N-channel Field Effect Transistor (NFET) and turns ON internal provider load switch

### LDO

- Integrated high-voltage LDO operational up to 21.5 V for dead battery mode operation

### 32-bit MCU Subsystem

- 48-MHz Arm Cortex-M0 CPU
- 64-KB Flash
- 96-KB ROM
- 16-KB SRAM

### Integrated Digital Blocks

- Two integrated timers and counters to meet response times required by the USB-PD protocol
- Four run-time serial communication blocks (SCBs) with reconfigurable I<sup>2</sup>C, SPI, or UART functionality

### Authentication

- True Random Number Generator

### Clocks and Oscillators

- Integrated oscillator eliminating the need for an external clock

### Operating Range

- VSYS (2.75 V–5.5 V)
- VBUS (4 V–21.5 V)

### Hot-Swappable I/Os

- I<sup>2</sup>C pins from SCB0 are hot-swappable

### Packages

- CCG6DF and CCG6SF: 6.0 mm × 6.0 mm × 1.0 mm, 96-ball BGA with 0.5-mm pitch
- CCG6SF: 6.0 mm × 6.0 mm × 0.6 mm, 48-pin QFN with 0.4-mm pitch

#### Notes

1. DFP refers to power source.
2. UFP refers to power sink.

**Logic Block Diagram**

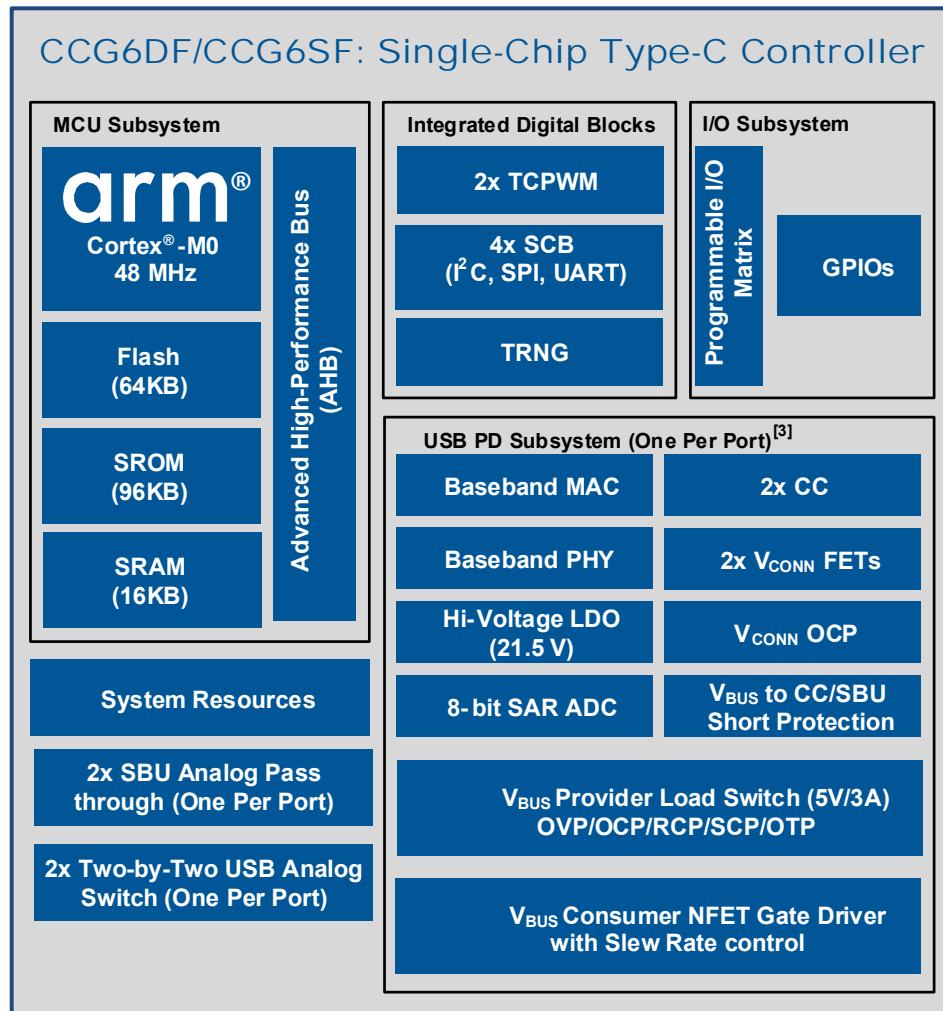

**Note**

3. Only one USB-PD subsystem exists for CCG6SF devices since it has only one Type-C port available.

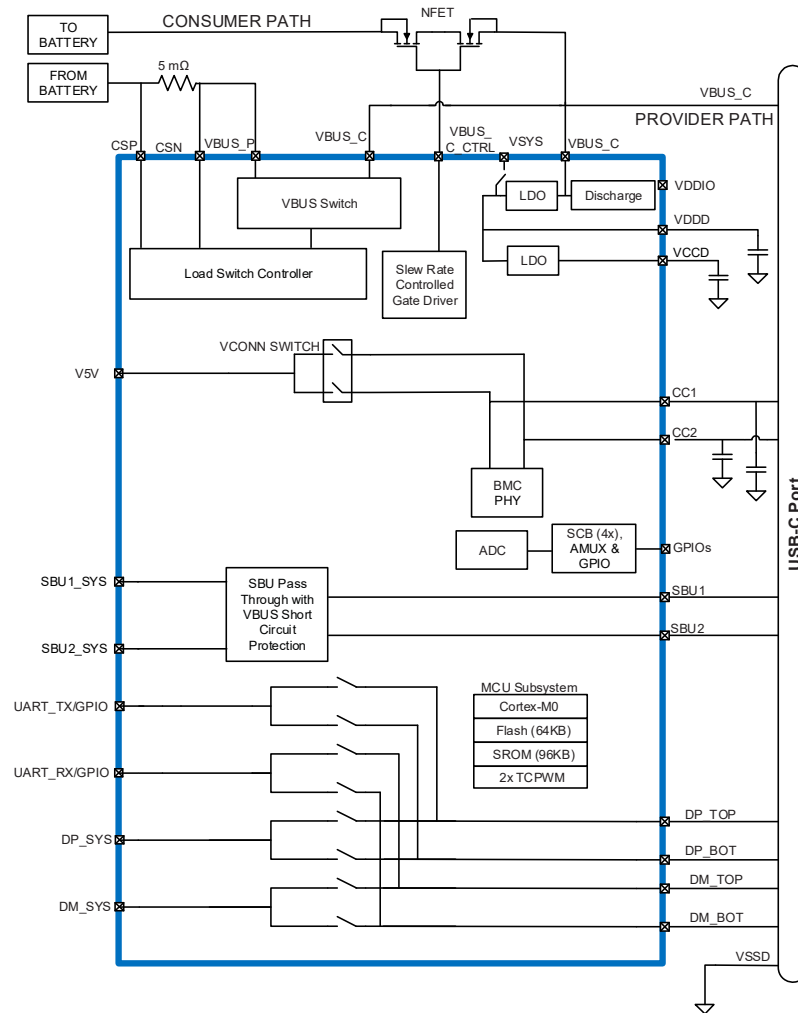
**CCG6DF/CCG6SF Functional Diagram**

**Note**

To simplify, the functional block diagram is shown only for one port.

## Contents

<b>Functional Overview</b> .....	<b>5</b>	Device-Level Specifications .....	30
MCU Subsystem .....	5	Digital Peripherals .....	33
USB-PD Subsystem (SS) .....	5	System Resources .....	35
Provider Load Switch .....	6	<b>Ordering Information</b> .....	<b>42</b>
Serial Communication Block (SCB) .....	7	Ordering Code Definitions .....	42
Timer, Counter, Pulse-Width Modulator (TCPWM) .....	7	<b>Packaging</b> .....	<b>43</b>
True Random Number Generator (TRNG) .....	7	<b>Acronyms</b> .....	<b>46</b>
GPIO Interface .....	7	<b>Document Conventions</b> .....	<b>47</b>
System Resources .....	7	Units of Measure .....	47
<b>Power</b> .....	<b>8</b>	References and Links to Applications Collateral .....	48
<b>Pinouts</b> .....	<b>10</b>	<b>Document History Page</b> .....	<b>49</b>
<b>Application Diagrams</b> .....	<b>18</b>	<b>Sales, Solutions, and Legal Information</b> .....	<b>50</b>
<b>CCG6DF, CCG6SF Layout Design Guidelines for BGA</b>		Worldwide Sales and Design Support .....	50
<b>Package</b> .....	<b>21</b>	<a href="#">Products</a> .....	50
Usage of Via Size of 8-mil drill/16-mil diameter and		<a href="#">PSoC® Solutions</a> .....	50
10-mil drill/16-mil diameter .....	21	Cypress Developer Community .....	50
<b>Electrical Specifications</b> .....	<b>29</b>	Technical Support .....	50
Absolute Maximum Ratings .....	29		

## Functional Overview

### MCU Subsystem

#### CPU

The Cortex M0 in CCG6DF and CCG6SF devices is a 32-bit MCU, which is optimized for low-power operation with extensive clock gating. It mostly uses 16-bit instructions and executes a subset of the Thumb-2 instruction set, which enables fully compatible binary upward migration of code to higher performance processors such as Cortex M3 and M4. Also included is a hardware multiplier, which provides a 32-bit result in one cycle. It includes an Interrupt Controller (the NVIC block) with 32 Interrupt inputs and a Wakeup Interrupt Controller (WIC), which can wake the processor up from Deep Sleep mode.

#### Flash, SRAM, and RAM

The 64-KB Flash and 96-KB ROM store the firmware implementing PD functionality.

The 16-KB RAM is used under software control to store temporary status of system variables and parameters. A supervisory ROM that contains boot and configuration routines is provided.

### USB-PD Subsystem (SS)

This subsystem provides the interface to the Type-C USB port. This subsystem comprises of:

- USB-PD Physical Layer
- VCONN FETs
- ADC
- SBU pass-through switch and USB HS mux
- Undervoltage, overvoltage and Reverse-Current Protection on VBUS
- High-side current sense amplifier for VBUS
- VBUS Discharge
- VBUS Regulator
- Consumer Gate Driver for VBUS NFET
- Integrated VBUS Provider path load switch with FRS
- VBUS tolerant SBU and CC pins

#### USB-PD Physical Layer

The USB-PD subsystem contains the USB-PD physical layer block and supporting circuits. The USB-PD Physical Layer consists of a transmitter and receiver that communicate BMC encoded data over the CC channel per the PD 3.0 standard. All communication is half-duplex. The Physical Layer or PHY practices collision avoidance to minimize communication errors on the channel.

In addition, the USB-PD block includes all termination resistors ( $R_P$  and  $R_D$ ) and their switches as required by the USB Type-C spec.  $R_P$  and  $R_D$  resistors are required to implement connection detection, plug orientation detection and for establishment of the USB source/sink roles. The  $R_P$  resistor is implemented as a current source.

The  $R_D$  resistors on CC pins are required even when the part is not powered on. This is required for dead battery termination detection and charging.

To support the latest USB-PD 3.0 specification, CCG6DF and CCG6SF devices implement the FRS feature. Fast Role Swap enables externally powered docks and hubs to rapidly switch to bus power when their external power supply is removed. This feature is supported for provider N-FET Gate Driver Output (NGDO). SCP and RCP fault detection are not enabled during the FRS sequence and it is assumed that provider side supply is present and higher than 4.85 V.

CCG6DF and CCG6SF devices are designed to be fully interoperable with revision 3.0 of the USB Power Delivery specification as well as revision 2.0 of the USB Power Delivery specification.

#### VCONN FET

CCG6DF and CCG6SF devices have power supply input V5V pin for providing power to EMCA cables through integrated VCONN FETs. There are two VCONN FETs per port in CCG6DF and CCG6SF devices to power either CC1 or CC2 pins. These FETs source a minimum of 1.5-W power per port over the valid VCONN range of 4.85 V to 5.5 V on the CC1/2 pins when providing power to EMCA cables. At any given time, only one of the VCONN FETs is in ON state to provide VCONN on either CC1 or CC2 lines depending on the cable orientation. The floating V5V pin does not cause CCG6DF to malfunction and draw more current.

#### ADC

CCG6DF and CCG6SF devices have a low power 8-bit SAR ADC that has access to the chip-wide analog mux. All GPIOs on these devices have access to the ADCs through the chip-wide analog mux.

#### SBU Pass-Through Switch and USB HS Mux

CCG6DF has integrated 2x SBU pass-through switches and 2x high-speed (480 Mbps) switches as shown in [Figure 1](#).

The SBU switch is a simple pass-through switch. The Type-C facing SBU pins are protected from accidental short to VBUS.

The HS mux contains a 2x2 cross bar switch to route the system DP/DM lines to the Type-C top or bottom lines as per the CC (Type-C plug) orientation and connect the Debug pins to unused DP or DM top or bottom pins.

**Figure 1. SBU Protection and High-Speed Crossbar Switch Block Diagram**

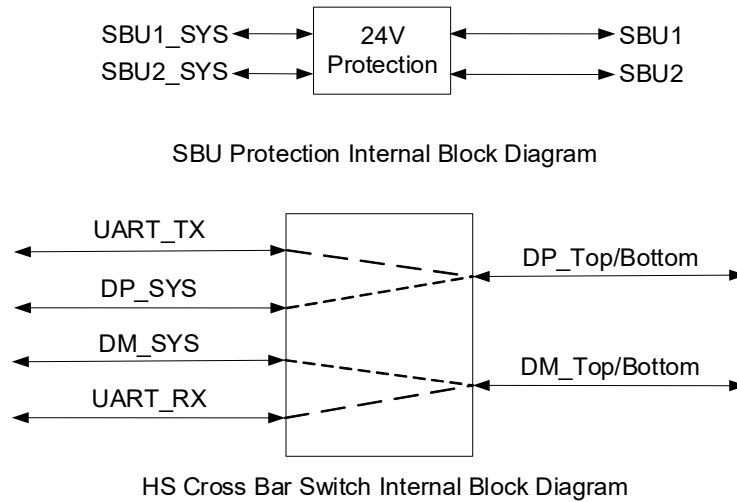

**Provider Load Switch**

CCG6DF and CCG6SF devices have an integrated provider load switch with the following functions.

*Undervoltage and Overvoltage Protection on VBUS*

CCG6DF and CCG6SF devices implement an under-voltage/overvoltage (UVOV) detection circuit for the VBUS supply. The thresholds for both OCP and UVOV are programmable.

*High-side Current Sense Amplifier for VBUS*

CCG6DF and CCG6SF devices support the programmable threshold VBUS current sensing through VBUS provider path. External resistor (5 mΩ) placed in VBUS provider path connecting to the chip, the drop across this resistor is monitored to sense the magnitude of current.

*VBUS Reverse Current Protection*

CCG6DF and CCG6SF devices restrict reverse current to zero on the VBUS provider path when the Type-C VBUS is greater than VIN (provider voltage before the VBUS NFET).

*VBUS Short Circuit Protection*

CCG6DF and CCG6SF devices have a VBUS short circuit protection function of which the SCP threshold is programmable. Whenever current through the VBUS Provider Load Switch exceeds the programmed threshold, the SCP gets triggered instantly and turns off the VBUS provider path within a short duration.

*VBUS Discharge*

CCG6DF and CCG6SF devices support high-voltage (21.5 V) VBUS discharge circuitry inside. After cable removal detection, the chips discharge the residual charge and bring the floating VBUS to less than 0.8 V.

*VBUS Regulator*

CCG6DF and CCG6SF devices can either be powered by VSYS or VBUS power supplies. There is one VBUS per port. Hence the CCG6DF device can be powered by either VBUS (Port0 or Port1) or VSYS. A regulator operating on these power supplies derives the chip operating supply. When both power supplies are present, VSYS always takes priority over VBUS supplies. In absence of VSYS, the regulator powers the chip from VBUS.

*Gate Driver for VBUS NFET*

CCG6DF and CCG6SF devices have integrated gate drivers to drive external NFETs on the VBUS consumer path. The provider NFETs are integrated. The consumer side supports only the external NFET driver and these NFETs must be capable of supporting ±VBUS\_MAX VGS. CCG6DF and CCG6SF must be in active mode to enable the consumer-side NGDO.

*VBUS Tolerant SBU and CC Lines*

CCG6DF and CCG6SF devices support VBUS tolerant SBU and CC lines. In case of SBU/CC short to VBUS through connectors, these lines are protected internally. Accidental shorts may occur because the SBU/CC pins are placed next to the VBUS pins in the USB Type-C connector. A Power Delivery controller without the high-voltage VBUS short protection will be damaged in the event of such accidental shorts. When overvoltage is detected on the SBU/CC lines, the internal protection circuit will turn off the connection between the Type-C connector and the rest of the device.

### Serial Communication Block (SCB)

CCG6DF and CCG6SF devices have four SCB blocks that can be configured for I<sup>2</sup>C, SPI, or UART. These blocks implement full multi-master and slave I<sup>2</sup>C interfaces capable of multi-master arbitration. I<sup>2</sup>C is compatible with the standard Philips I<sup>2</sup>C Specification V3.0. These blocks operate at speeds of up to 1 Mbps and have flexible buffering options to reduce interrupt overhead and latency for the CPU.

The SCB blocks support 8-byte deep FIFOs for Receive and Transmit, which, by increasing the time given for the CPU to read data, greatly reduces the need for clock stretching caused by the CPU not having read data on time.

### Timer, Counter, Pulse-Width Modulator (TCPWM)

The TCPWM block of CCG6DF and CCG6SF supports up to two timers or counters or pulse-width modulators. These timers are available for internal timer use by firmware or for providing PWM-based functions on the GPIOs.

### True Random Number Generator (TRNG)

In notebook designs, CCG6DF's and CCG6SF's TRNG block is used in authenticating connected devices such as power adapters or docks that include support for USB Type-C Authentication Specification (USBTCAS). CCG6DF and CCG6SF devices, within notebook applications, are implemented as an initiate role as defined in USBTCAS, while the connected device would implement the responder-role. USBTCAS provides a means for authenticating Type-C devices with regards to identification and configuration.

### GPIO Interface

The CCG6DF device has 23 GPIOs and the CCG6DSF device has 20 GPIOs including the I<sup>2</sup>C and SWD pins, which can also be used as GPIOs.

The GPIO block implements the following:

- Eight drive strength modes including strong push-pull, resistive pull-up and pull-down, weak (resistive) pull-up and pull-down, open drain and open source, input only, and disabled.
- Input threshold select (CMOS or LVTTTL)
- Individual control of input and output disables.
- Hold mode for latching previous state (used for retaining I/O state in Deep Sleep mode).
- Selectable slew rates for dV/dt related noise control.

During power-on and reset, the blocks are forced to the Disable state so as not to crowbar any inputs and/or cause excess turn-on current. A multiplexing network known as a high-speed I/O matrix is used to multiplex between various signals that may

connect to an I/O pin. Pin locations for fixed-function peripherals, such as USB Type-C ports, are also fixed to reduce internal multiplexing complexity. Data Output Registers and Pin State Register store, respectively, the values to be driven on the pins and the states of the pins themselves. The configuration of the pins can be done by programming of registers through software for each digital I/O Port.

Every I/O pin can generate an interrupt if so enabled and each I/O port has an IRQ and ISR vector associated with it.

The I/O ports retain their state during Deep Sleep mode or remain ON. If operation is restored using reset, then the pins shall go the High-Z state. If operation is restored by an interrupt event, then the pin drivers shall retain their state until firmware chooses to change it. The I/Os (on data bus) do not draw current on power down.

All GPIOs reside in a separate I/O power domain – VDDIO to provide flexible system-level interfacing.

### System Resources

#### *Watchdog Timer (WDT)*

A watchdog timer is implemented in the Clock block running from the internal low-speed oscillator (ILO) for CCG6DF and CCG6SF devices. This allows watchdog operation during Deep Sleep and generates a Watchdog Reset if not serviced before the timeout occurs.

#### *Clock System*

CCG6DF and CCG6SF have a fully integrated clock with no external crystal required. CCG6DF/CCG6SF clock system is responsible for providing clocks to all subsystems that require clocks (SCB and USB-PD) and for switching between different clock sources, without glitches. The clock system for these devices consists of the internal main oscillator (IMO) and the ILO.

#### *IMO Clock Source*

The IMO is the primary source of internal clocking in CCG6DF and CCG6SF devices with an accuracy of  $\pm 2\%$ . The default IMO frequency for CCG6DF and CCG6SF devices is 48 MHz  $\pm 2\%$ .

#### *ILO Clock Source*

The ILO is a very low power, relatively inaccurate, oscillator, which is primarily used to generate clocks for peripheral operation in USB Suspend (Deep Sleep) mode. The typical frequency of the ILO is 32-kHz.

**Power**

CCG6DF can operate either from VBUS\_C (from Port 0 and/or 1) or V<sub>SYS</sub> supply inputs. In addition, there is V5V supply pin, which sources the V<sub>CONN</sub> supply to the Type-C connector, the valid levels on V5V supply can range from 4.85 – 5.5 V. V5V does not power the chip. The chip's internal operating power supply is derived from V<sub>SYS</sub> (2.75 V to 5.5 V) or VBUS (4 V- 21.5 V). In dead battery mode, the chip can be supplied power from Type-C VBUS (from port 0 and/or 1). In UFP, DFP, and DRP modes (when the system battery is charged), the chip is powered via V<sub>SYS</sub>. CCG6DF and CCG6SF devices support power modes to minimize energy consumption when not actively involved in data communication over the Type-C port.

Figure 2 and Figure 3 show an overview of the power system requirement for CCG6DF and CCG6SF devices. CCG6DF and CCG6SF devices have two different power modes: Active and Deep Sleep, transitions between which are managed by the Power System. A separate power domain, V<sub>DDIO</sub>, is provided for the GPIOs and V<sub>DDD</sub> which generates 3.3 V from internal regulator. V<sub>DDD</sub> can be shorted to V<sub>DDIO</sub>. V<sub>DDD</sub> and V<sub>CCD</sub> are not recommended to be used as power supplies for other circuits on the system. Also, V<sub>DDD</sub> and V<sub>CCD</sub> pins cannot be treated as power sources for the chip. The V<sub>CCD</sub> pin, the output of the core (1.8 V) regulator, is brought out for connecting a 0.1-μF capacitor for the regulator stability only.

**Figure 2. CCG6DF Power Supply Requirement Block Diagram**

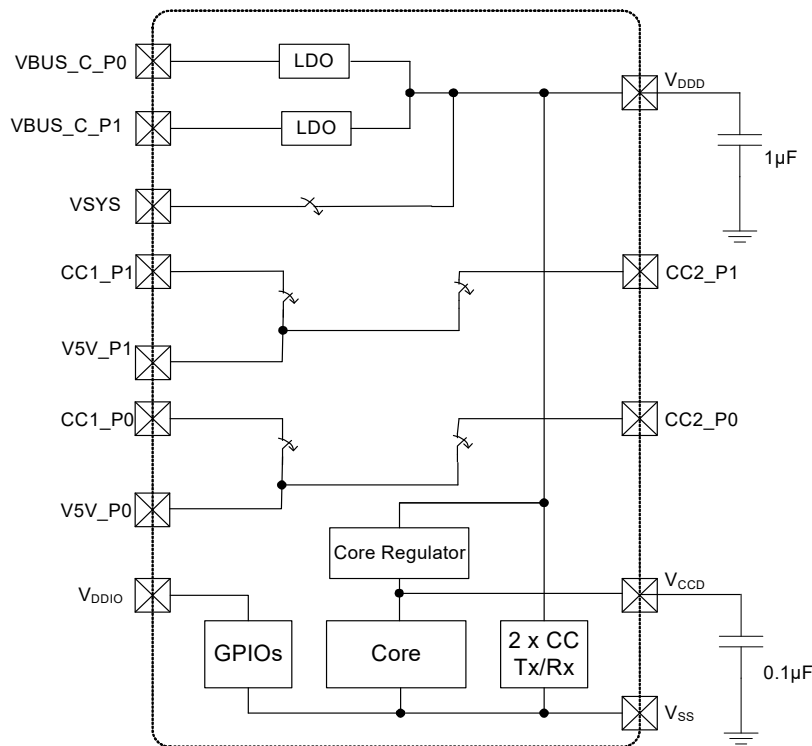



**Figure 3. CCG6SF Power Supply Requirement Block Diagram**

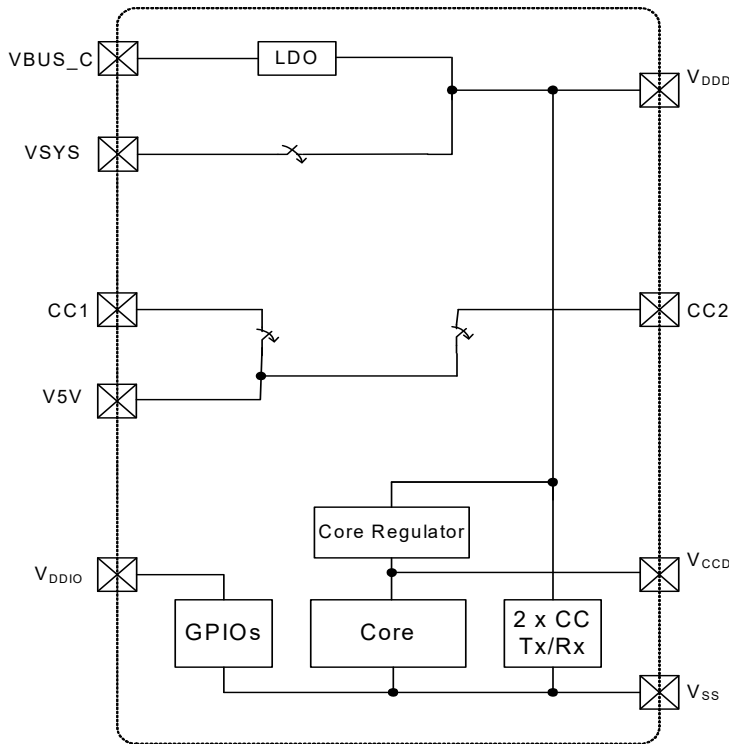

**Table 1. CCG6DF/CCG6SF Power Modes**

Mode	Description
Reset	Power is Valid and XRES is not asserted. An internal reset source is asserted or Sleep Controller is sequencing the system out of reset.
ACTIVE	Power is Valid and CPU is executing instructions. This mode includes the critical Type-C power spec requirement.
DEEP SLEEP	Main regulator and most hard-IP are shut off. DeepSleep regulator powers logic, but only low-frequency clock is available.

## Pinouts

**Table 2. Pinout for CYPD6227-96BZXI**

Group Name	Pin Name	Port	Pin	Description
USB Type-C	CC1_P0	Analog	B3	USB PD Port-0 connector detect/Configuration Channel 1
	CC2_P0	Analog	B5	USB PD Port-0 connector detect/Configuration Channel 2
	CC1_P1	Analog	K5	USB PD Port-1 connector detect/Configuration Channel 1
	CC2_P1	Analog	K3	USB PD Port-1 connector detect/Configuration Channel 2
Muxes/Switches	DP_SYS_P0	Analog	K11	USB 2.0 DP from the Host System: Port-0
	DM_SYS_P0	Analog	J11	USB 2.0 DM from the Host System: Port-0
	UART_TX_P0/P1.4	GPIO	H10	UART Tx from Host System: Port-0/GPIO
	UART_RX_P0/P1.3	GPIO	G10	UART Rx from Host System: Port-0/GPIO
	DP_BOT_P0	Analog	K10	USB 2.0 DP from Bottom of Type-C Connector: Port-0
	DM_BOT_P0	Analog	J10	USB 2.0 DM from Bottom of Type-C Connector: Port-0
	DM_TOP_P0	Analog	H11	USB 2.0 DM from Top of Type-C Connector: Port-0
	DP_TOP_P0	Analog	G11	USB 2.0 DP from Top of Type-C Connector: Port-0
	SBU2_P0	Analog	A4	Type-C Sideband Use signal – Connector side: Port-0
	SBU1_P0	Analog	A5	Type-C Sideband Use signal – Connector side: Port-0
	SBU1_SYS_P0	Analog	B6	Type-C Sideband Use signal – System side: Port-0
	SBU2_SYS_P0	Analog	A6	Type-C Sideband Use signal – System side: Port-0
	DP_SYS_P1	Analog	L6	USB 2.0 DP from the Host System: Port-1
	DM_SYS_P1	Analog	L5	USB 2.0 DM from the Host System: Port-1
	UART_TX_P1/P0.0	GPIO	L4	UART Tx from Host System: Port-1/GPIO
	UART_RX_P1/P0.1	GPIO	K6	UART Rx from Host System: Port-1/GPIO
	DP_BOT_P1	Analog	K8	USB 2.0 DP from Bottom of Type-C Connector: Port-1
	DM_BOT_P1	Analog	K7	USB 2.0 DM from Bottom of Type-C Connector Port-1
	DM_TOP_P1	Analog	L7	USB 2.0 DM from Top of Type-C Connector: Port-1
	DP_TOP_P1	Analog	L8	USB 2.0 DP from Top of Type-C Connector: Port-1
	SBU2_P1	Analog	A9	Type-C Sideband Use signal – Connector side: Port-1
	SBU1_P1	Analog	A8	Type-C Sideband Use signal – Connector side Port-1
SBU1_SYS_P1	Analog	B7	Type-C Sideband Use signal – System side: Port-1	
SBU2_SYS_P1	Analog	A7	Type-C Sideband Use signal – System side: Port-1	
VBUS Control	VBUS_C_CTRL_P0	Analog	A3	Full rail control I/O for enabling/disabling Consumer load NFET of USB Type-C Port-0
	VBUS_C_CTRL_P1	Analog	L3	Full rail control I/O for enabling/disabling Consumer load NFET of USB Type-C Port-1
VBUS OCP	CSP_P0	Analog	A11	Current Sense Positive Input for VBUS side external Rsense: Port-0
	CSN_P0	Analog	A10	Current Sense Negative input for other side of external Rsense: Port-0
	CSP_P1	Analog	L11	Current Sense Positive Input for VBUS side external Rsense: Port-1
	CSN_P1	Analog	L10	Current Sense Negative input for other side of external Rsense: Port-1

**Table 2. Pinout for CYPD6227-96BZXI (continued)**

Group Name	Pin Name	Port	Pin	Description
GPIOs and Serial Interfaces	I2C_SDA_SCB1/P0.2	GPIO	K9	SCB1 data for communicating with SoC or TBT controller/ GPIO
	I2C_SCL_SCB1/P0.3	GPIO	H7	SCB1 clock for communicating with SoC or TBT controller / GPIO
	I2C_INT_EC/P1.2	GPIO	F11	Embedded Controller interrupt / GPIO
	P2.4	GPIO	D10	GPIO
	I2C_INT_TBT_P0/P0.4	GPIO	L9	ThunderBolt interrupt for Port-0 / GPIO
	SWD_IO/P1.1	GPIO	G8	Serial Wire Debug I/O / GPIO
	SWD_CLK/P1.0	GPIO	F10	Serial Wire Debug Clock / GPIO
	HPD_P0/P2.0	GPIO	F8	Hot Plug Detect I/O for Port-0 / GPIO
	I2C_SDA_SCB2/P2.1	GPIO	E11	SCB2 data for configuring Re-timer or DP/USB Multi-Function MUX/ GPIO
	I2C_SCL_SCB2/P2.2	GPIO	E10	SCB2 clock for configuring Re-timer or DP/USB Multi-Function MUX/ GPIO
	P2.3	GPIO	E8	GPIO
	I2C_INT_TBT_P1/P0.5	GPIO	H8	ThunderBolt interrupt for Port-1 / GPIO
	P2.5	GPIO	D8	GPIO
	I2C_SCL_SCB0/P4.0	GPIO	D11	SCB0 clock for communicating with Embedded controller / GPIO
	I2C_SDA_SCB0/P4.1	GPIO	C11	SCB0 data for communicating with Embedded controller / GPIO
	P3.0	GPIO	B10	GPIO
	I2C_SDA_SCB3/P3.1	GPIO	B11	SCB3 data / GPIO
	I2C_SCL_SCB3/P3.2	GPIO	B9	SCB3 clock / GPIO
HPD_P1/P3.3	GPIO	B8	Hot Plug Detect I/O for Port-1 / GPIO	
Reset	XRES	Analog	C10	Reset input
Power	VBUS_C_P0	Power	A1,A2,B1,B2,C1	Type-C VBUS Connector Input for Port-0 (4-V to 21.5-V)
	VBUS_C_P1	Power	J1,K1,K2,L1,L2	Type-C VBUS Connector Input for Port-1 (4-V to 21.5-V)
	VBUS_P_P0	Power	C2,D1,D2,E1,E2	VBUS Provider Input for Port-0 (4-V to 5.5-V)
	VBUS_P_P1	Power	G1,G2,H1,H2,J2	VBUS Provider Input for Port-1 (4-V to 5.5-V)
	VSYS	Power	F4	2.75-V to 5.5-V supply for the system
	VDDD	Power	G7	VDDD supply output 1. VSYS powered - (Min: VSYS-50 mV) 2.7 to 5.5 2. VBUS powered - 3.0 V to 3.6 V
	VDDIO	Power	F7	At system-level short the VDDD to VDDIO
	VCCD	Power	E7	1.8-V regulator output for filter capacitor. This pin cannot drive external load.
	V5V_P0	Power	B4	4.85-V to 5.5-V supply for VCONN FET of Type-C: Port-0
	V5V_P1	Power	K4	4.85-V to 5.5-V supply for VCONN FET of Type-C: Port-1
Ground	VSSD	Ground	D7, E5, E6, F1, F2, F5, F6, G4, G5, G6	Ground

**Table 3. Pinout for CYPD6127-96BZXI**

Group Name	Pin Name	Port	Pin	Description
USB Type-C	CC1	Analog	B3	USB PD connector detect/Configuration Channel 1
	CC2	Analog	B5	USB PD connector detect/Configuration Channel 2
Muxes/Switches	DP_SYS	Analog	K11	USB 2.0 DP from the Host System
	DM_SYS	Analog	J11	USB 2.0 DM from the Host System
	UART_TX/P1.4	GPIO	H10	UART Tx from Host System/GPIO
	UART_RX/P1.3	GPIO	G10	UART Rx from Host System/GPIO
	DP_BOT	Analog	K10	USB 2.0 DP from Bottom of Type-C Connector
	DM_BOT	Analog	J10	USB 2.0 DM from Bottom of Type-C Connector
	DM_TOP	Analog	H11	USB 2.0 DM from Top of Type-C Connector
	DP_TOP	Analog	G11	USB 2.0 DP from Top of Type-C Connector
	SBU2	Analog	A4	Type-C Sideband Use signal – Connector side
	SBU1	Analog	A5	Type-C Sideband Use signal – Connector side
	SBU1_SYS	Analog	B6	Type-C Sideband Use signal – System side
	SBU2_SYS	Analog	A6	Type-C Sideband Use signal – System side
VBUS Control	VBUS_C_CTRL	Analog	A3	Full rail control I/O for enabling/disabling Consumer load NFET of USB Type-C
VBUS OCP	CSP	Analog	A11	Current Sense Positive Input for VBUS side external Rsense
	CSN	Analog	A10	Current Sense Negative input for other side of external Rsense
GPIOs and Serial Interfaces	I2C_SDA_SCB1/P0.2	GPIO	K9	SCB1 data for communicating with SoC or TBT controller/ GPIO
	I2C_SCL_SCB1/P0.3	GPIO	H7	SCB1 clock for communicating with SoC or TBT controller / GPIO
	I2C_INT_EC/P1.2	GPIO	F11	Embedded Controller interrupt / GPIO
	I2C_INT_TBT/P0.4	GPIO	L9	ThunderBolt interrupt / GPIO
	SWD_IO/P1.1	GPIO	G8	Serial Wire Debug I/O / GPIO
	SWD_CLK/P1.0	GPIO	F10	Serial Wire Debug Clock / GPIO
	HPD/P2.0	GPIO	F8	Hot Plug Detect I/O / GPIO
	I2C_SDA_SCB2/P2.1	GPIO	E11	SCB2 data for configuring Re-timer or DP/USB Multi-Function MUX/ GPIO
	I2C_SCL_SCB2/P2.2	GPIO	E10	SCB2 clock for configuring Re-timer or DP/USB Multi-Function MUX/ GPIO
	P2.3	GPIO	E8	GPIO
	P2.4	GPIO	D10	GPIO
	P2.5	GPIO	D8	GPIO
	I2C_SCL_SCB0/P4.0	GPIO	D11	SCB0 clock for communicating with Embedded controller / GPIO
	I2C_SDA_SCB0/P4.1	GPIO	C11	SCB0 data for communicating with Embedded controller / GPIO
	P3.0	GPIO	B10	GPIO
I2C_SDA_SCB3/P3.1	GPIO	B11	SCB3 data / GPIO	

**Table 3. Pinout for CYPD6127-96BZXI (continued)**

Group Name	Pin Name	Port	Pin	Description
GPIOs and Serial Interfaces	I2C_SCL_SCB3/P3.2	GPIO	B9	SCB3 clock / GPIO
	P3.3	GPIO	B8	GPIO
Reset	XRES	Analog	C10	Reset input
Power	VBUS_C	Power	A1,A2,B1,B2,C1	Type-C VBUS Connector Input (4-V to 21.5-V)
	VBUS_P	Power	C2,D1,D2,E1,E2	VBUS Provider Input (4-V to 5.5-V)
	VSYS	Power	F4	2.75-V to 5.5-V Supply for the System
	VDDD	Power	G7	VDDD supply output 1. VSYS powered - (Min: VSYS-50 mV) 2.7 to 5.5 2. VBUS powered - 3.0V to 3.6V
	VDDIO	Power	F7	At system-level short the VDDD to VDDIO
	VCCD	Power	E7	1.8-V regulator output for filter capacitor. This pin cannot drive external load.
	V5V	Power	B4	4.85-V to 5.5-V supply for VCONN FET of Type-C
Ground	VSSD	Ground	D7, E5, E6, F1, F2, F5, F6, G4, G5, G6	Ground

**Figure 4. 96-Ball BGA Pin Map (Top View) for CYPD6227-96BZXI**

	1	2	3	4	5	6	7	8	9	10	11
A	VBUS_C_P0	VBUS_C_P0	VBUS_C_CTRL_P0	SBU2_P0	SBU1_P0	SBU2_SYS_P0	SBU2_SYS_P1	SBU1_P1	SBU2_P1	CSN_P0	CSP_P0
B	VBUS_C_P0	VBUS_C_P0	CC1_P0	V5V_P0	CC2_P0	SBU1_SYS_P0	SBU1_SYS_P1	HPD_P1/P3.3	I2C_SCL_SCB3/P3.2	P3.0	I2C_SDA_SCB3/P3.1
C	VBUS_C_P0	VBUS_P_P0								XRES	I2C_SDA_SCB0/P4.1
D	VBUS_P_P0	VBUS_P_P0			DNU	DNU	VSSD	P2.5		P2.4	I2C_SCL_SCB0/P4.0
E	VBUS_P_P0	VBUS_P_P0		DNU	VSSD	VSSD	VCCD	P2.3		I2C_SCL_SCB2/P2.2	I2C_SDA_SCB2/P2.1
F	VSSD	VSSD		VSYS	VSSD	VSSD	VDDIO	HPD_P0/P2.0		SWD_CLK/P1.0	I2C_INT_EC/P1.2
G	VBUS_P_P1	VBUS_P_P1		VSSD	VSSD	VSSD	VDDD	SWD_IO/P1.1		UART_RX_P0/P1.3	DP_TOP_P0
H	VBUS_P_P1	VBUS_P_P1		DNU	DNU	DNU	I2C_SCL_SCB1/P0.3	I2C_INT_TBT_P1/P0.5		UART_TX_P0/P1.4	DM_TOP_P0
J	VBUS_C_P1	VBUS_P_P1								DM_BOT_P0	DM_SYS_P0
K	VBUS_C_P1	VBUS_C_P1	CC2_P1	V5V_P1	CC1_P1	UART_RX_P1/P0.1	DM_BOT_P1	DP_BOT_P1	I2C_SDA_SCB1/P0.2	DP_BOT_P0	DP_SYS_P0
L	VBUS_C_P1	VBUS_C_P1	VBUS_C_CTRL_P1	UART_TX_P1/P0.0	DM_SYS_P1	DP_SYS_P1	DM_TOP_P1	DP_TOP_P1	I2C_INT_TBT_P0/P0.4	CSN_P1	CSP_P1

Type-C Port 1
Type-C Port 2
Power Pins
GND
GPIOs

**Figure 5. 96-Ball BGA Pin Map (Top View) for CYPD6127-96BZXI**

	1	2	3	4	5	6	7	8	9	10	11
A	VBUS_C	VBUS_C	VBUS_C_CTRL	SBU2	SBU1	SBU2_SYS	NC	NC	NC	CSN	CSP
B	VBUS_C	VBUS_C	CC1	V5V	CC2	SBU1_SYS	NC	P3.3	I2C_SCL_SCB3/P3.2	P3.0	I2C_SDA_SCB3/P3.1
C	VBUS_C	VBUS_P								XRES	I2C_SDA_SCB0/P4.1
D	VBUS_P	VBUS_P			DNU	DNU	VSSD	P2.5		P2.4	I2C_SCL_SCB0/P4.0
E	VBUS_P	VBUS_P		DNU	VSSD	VSSD	VCCD	P2.3		I2C_SCL_SCB2/P2.2	I2C_SDA_SCB2/P2.1
F	VSSD	VSSD		VSYS	VSSD	VSSD	VDDIO	HPD/P2.0		SWD_CLK/P1.0	I2C_INT_EC/P1.2
G	NC	NC		VSSD	VSSD	VSSD	VDDD	SWD_IO/P1.1		UART_RX/P1.3	DP_TOP
H	NC	NC		NC	NC	NC	I2C_SCL_SCB1/P0.3	NC		UART_TX/P1.4	DM_TOP
J	NC	NC								DM_BOT	DM_SYS
K	NC	NC	NC	NC	NC	NC	NC	NC	I2C_SDA_SCB1/P0.2	DP_BOT	DP_SYS
L	NC	NC	NC	NC	NC	NC	NC	NC	I2C_INT_TB1/P0.4	NC	NC

Type-C Port 1
NC
Power Pins
GND
GPIOs

**Table 4. Pinout for CYPD6127-48LQXI**

Group Name	Pin Name	Port	Pin	Description
USB Type-C	CC1	Analog	46	USB PD connector detect/Configuration Channel 1
	CC2	Analog	44	USB PD connector detect/Configuration Channel 2
Mux	DP_SYS	Analog	23	USB 2.0 DP from the Host System
	DM_SYS	Analog	22	USB 2.0 DM from the Host System
	UART_TX/P1.4	GPIO	24	UART Tx from Host System/GPIO
	UART_RX/P1.3	GPIO	25	UART Rx from Host System/GPIO
	DP_BOT	Analog	20	USB 2.0 DP from Bottom of Type-C Connector
	DM_BOT	Analog	21	USB 2.0 DM from Bottom of Type-C Connector
	DM_TOP	Analog	19	USB 2.0 DM from Top of Type-C Connector
	DP_TOP	Analog	18	USB 2.0 DP from Top of Type-C Connector
	SBU2	Analog	43	Type-C Sideband Use signal – Connector side
	SBU1	Analog	42	Type-C Sideband Use signal – Connector side
	SBU1_SYS	Analog	41	Type-C Sideband Use signal – System side
	SBU2_SYS	Analog	40	Type-C Sideband Use signal – System side
VBUS Control	VBUS_C_CTRL	Analog	47	Full rail control I/O for enabling/disabling Consumer load NFET of USB Type-C
VBUS OCP	CSP	Analog	39	Current Sense Positive Input for VBUS side external Rsense
	CSN	Analog	38	Current Sense Negative input for other side of external Rsense
GPIOs and Serial Interfaces	I2C_SDA_SCB1/P0.2	GPIO	16	SCB1 data / GPIO
	I2C_SCL_SCB1/P0.3	GPIO	13	SCB1 clock / GPIO
	I2C_INT_TBT/P0.4	GPIO	17	ThunderBolt interrupt / GPIO
	I2C_INT_EC/P1.2	GPIO	26	Embedded Controller interrupt / GPIO
	SWD_IO/P1.1	GPIO	14	Serial Wire Debug I/O / GPIO
	SWD_CLK/P1.0	GPIO	15	Serial Wire Debug Clock / GPIO
	HPD/P2.0	GPIO	27	Hot Plug Detect I/O / GPIO
	I2C_SDA_SCB2/P2.1	GPIO	28	SCB2 data / GPIO
	I2C_SCL_SCB2/P2.2	GPIO	29	SCB2 clock / GPIO
	P2.3	GPIO	30	GPIO
	P2.4	GPIO	31	GPIO
	I2C_SCL_SCB0/P4.0	GPIO	32	SCB0 clock / GPIO
	I2C_SDA_SCB0/P4.1	GPIO	33	SCB0 data / GPIO
	P3.0	GPIO	35	GPIO
	I2C_SDA_SCB3/P3.1	GPIO	36	GPIO
	I2C_SCL_SCB3/P3.2	GPIO	37	GPIO
	P3.3	GPIO	12	GPIO
Reset	XRES	Analog	34	Reset input



**Table 4. Pinout for CYPD6127-48LQXI (continued)**

Group Name	Pin Name	Port	Pin	Description
Power	VBUS_C	Power	1,2,3,48	Type-C VBUS Connector Input (4-V to 21.5-V)
	VBUS_P	Power	4,5,6,7	VBUS Provider Input (4-V to 5.5-V)
	VSYS	Power	8	2.75-V to 5.5-V Supply for the System
	VDDD	Power	11	VDDD supply output 1. VSYS powered - (Min: VSYS-50 mV) 2.7 to 5.5 2. VBUS powered - 3.0 V to 3.6 V
	VDDIO	Power	10	At system-level short the VDDD to VDDIO
	VCCD	Power	9	1.8-V regulator output for filter capacitor. This pin cannot drive external load.
	V5V	Power	45	4.85-V to 5.5-V supply for VCONN FET of Type-C
Ground	-	Ground	EPAD	Ground

**Figure 6. 48-pin QFN Pin Map for CYPD6127-48LQXI**

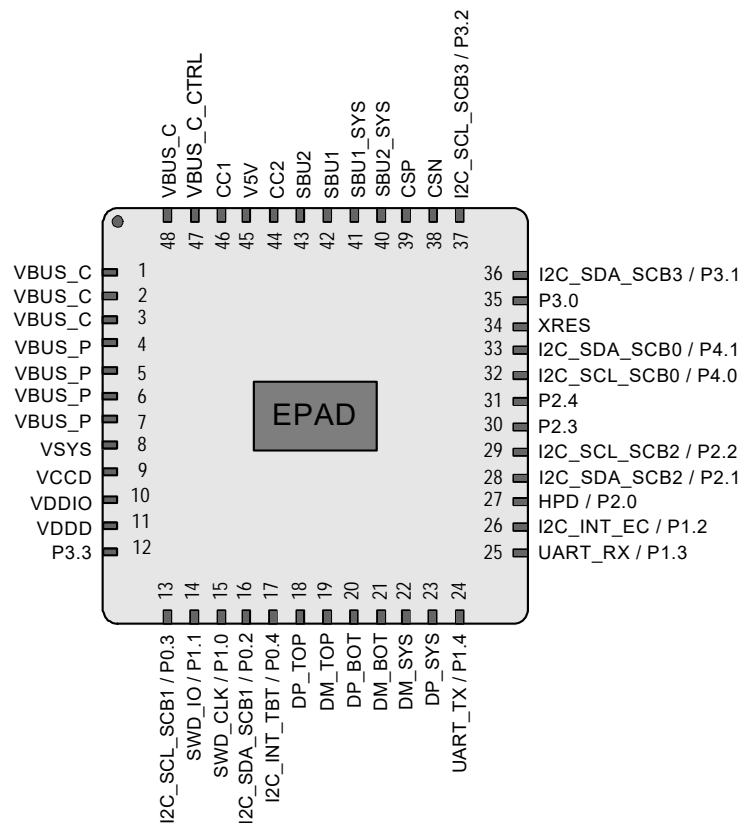

## Application Diagrams

The CCG6DF device communicates with the embedded controller (EC), which manages the Battery Charger Controller (BCC) to control the charging and discharging of the internal battery. It also updates the Thunderbolt Controller via I<sup>2</sup>C to route the HighSpeed signals coming from the Type-C port to the USB host (during normal mode) or the Graphics processor unit (during Display port Alternate mode) or the Thunderbolt Host (during Thunderbolt Alternate mode) based on the alternate mode negotiation.

The CCG6DF device controls the transfer of USB 2.0 DP and DM lines from the top and bottom of the Type-C receptacle to the DP and DM lines of the USB Host controller. CCG6DF offers VBUS Short protection on SBU and CC lines.

The CCG6DF device has integrated VCONN FETs for applications that need to provide power for accessories and cables using the VCONN pin of the Type-C receptacle. The 5-mΩ resistor between the 5-V supply and the integrated provider FETs is used for overcurrent detection on the VBUS.

Figure 7 illustrates a Dual Port Thunderbolt Notebook DRP application diagram using CYPD6227-96BZXI.

Figure 7. CCG6DF Dual Port Thunderbolt Notebook Application Diagram

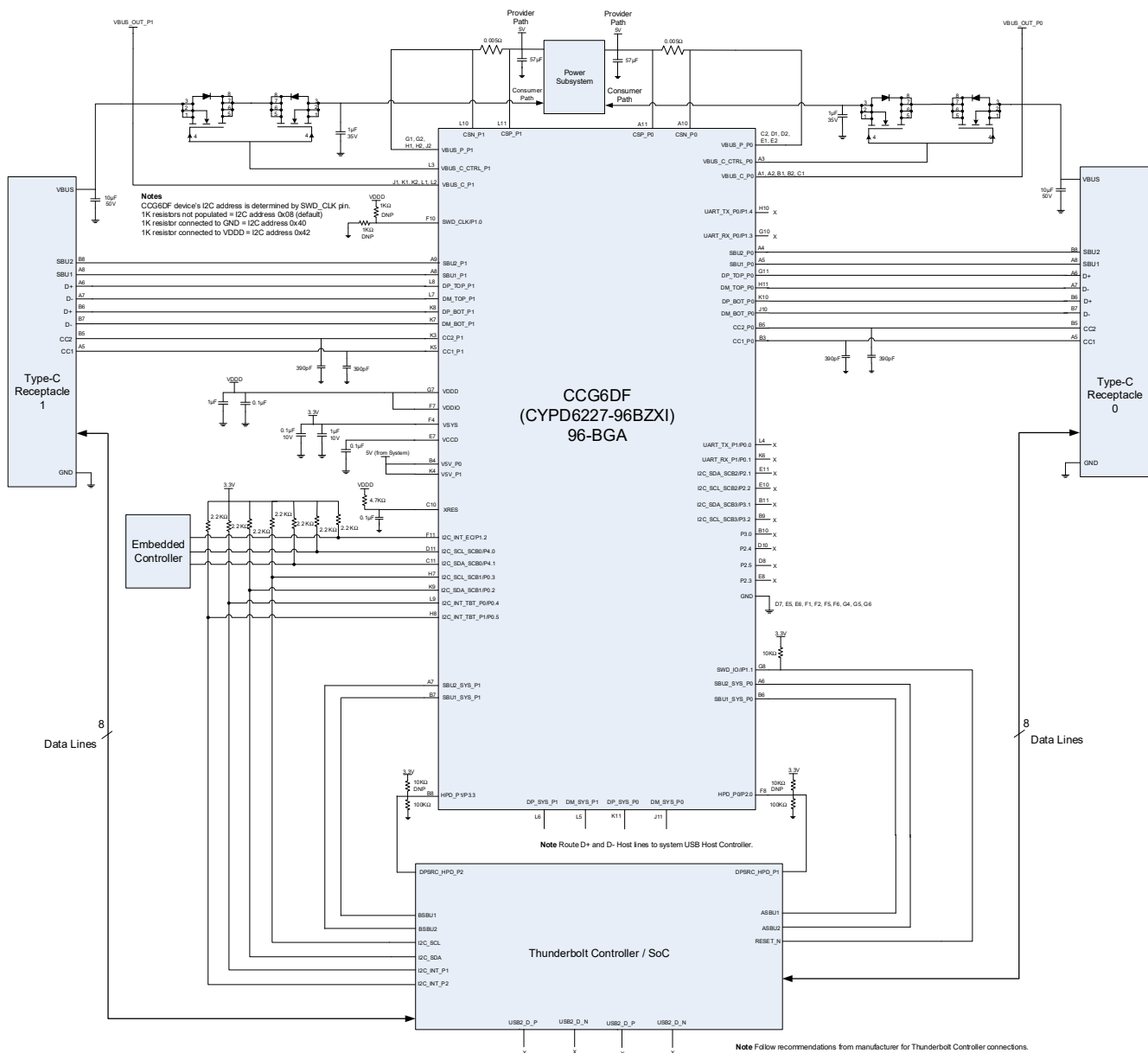

Figure 8 illustrates a Single-Port Thunderbolt Notebook DRP application diagram using CYPD6127-96BZXI.

Figure 8. CCG6SF 96-ball BGA Single Port Thunderbolt Notebook Application Diagram

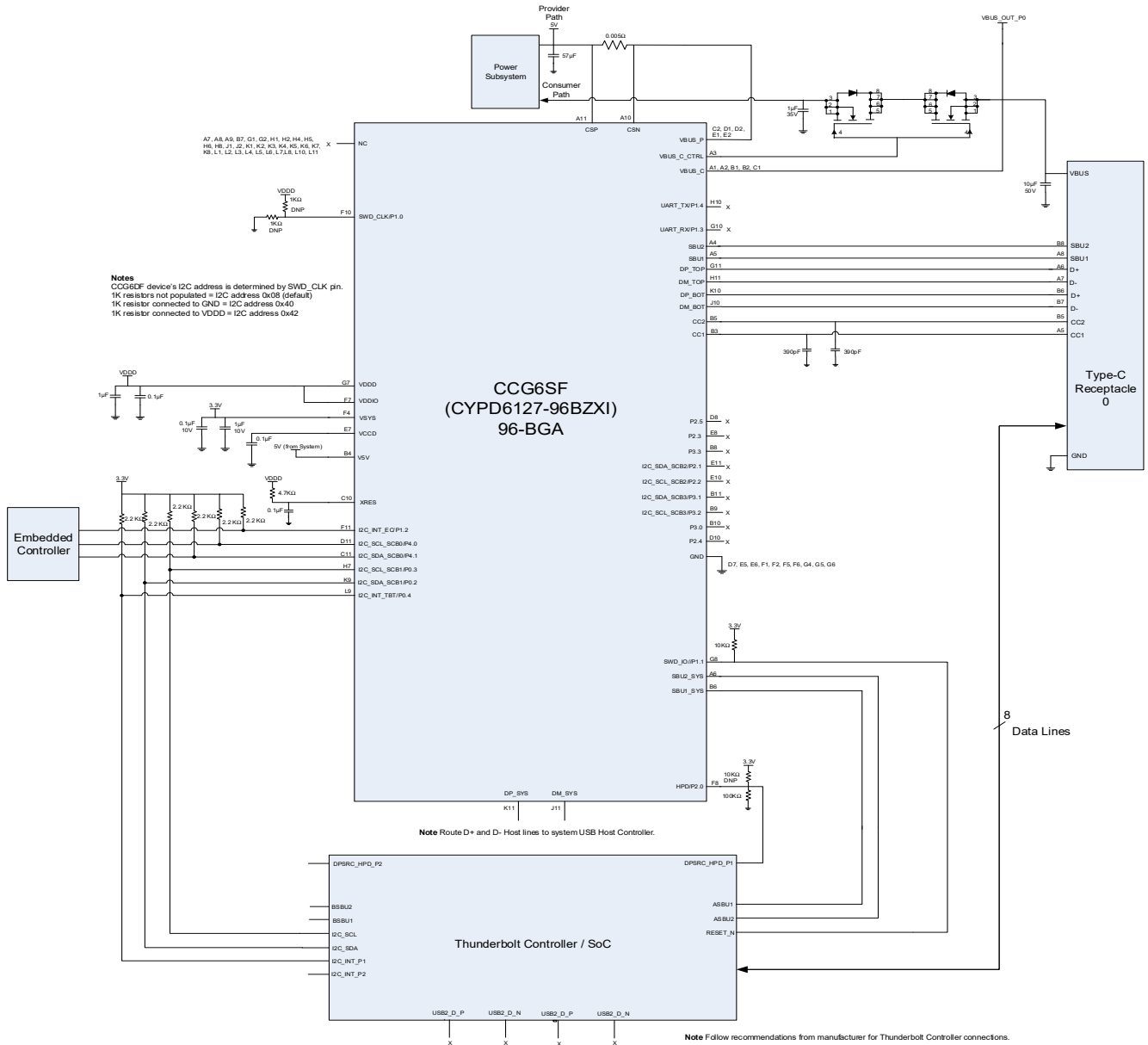
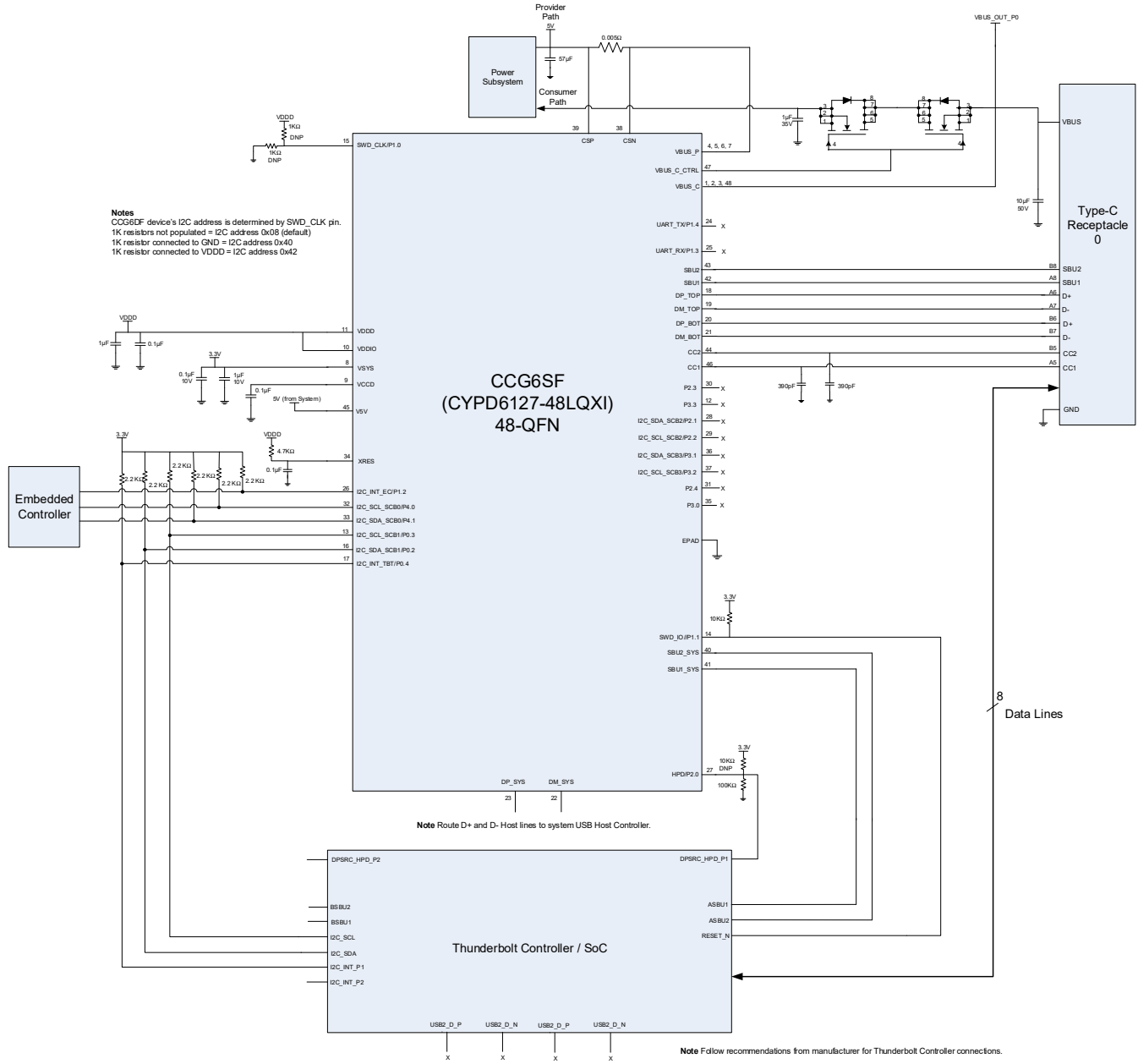

Figure 9 illustrates a Single-Port Thunderbolt Notebook DRP application diagram using CYPD6127-48LQXI.

**Figure 9. CCG6SF 48-pin QFN Single Port Thunderbolt Notebook Application Diagram**



**CCG6DF, CCG6SF Layout Design Guidelines for BGA Package**

Proper routing and placement help to maintain signal integrity for high-speed signals, improve thermal dissipation and reduce power consumption for CCG6DF/SF. The combination of power and high-speed data signals can be better routed if these design guidelines are followed. It is highly recommended to consult with a PCB manufacturer to verify the manufacturing capabilities to propose the right design guidelines. This section provides layout recommendations which are applicable to both CCG6DF and CCG6SF devices.

Figure 10 shows the CCG6DF 96-BGA device footprint that is recommended. The footprint has oval-shaped pads in specific locations. It is recommended to use oval pads in order to reduce the manufacturing cost by eliminating a High Density Interconnector (HDI) board processing. This method allows the PCB designer to route the inner perimeter balls through the top layer. The balls around the perimeter have their pads in an oval shape with the exception of the corner balls. Figure 11 shows the sizing for the oval pads, 0.25 mm by 0.17 mm. All of the other non-oval shaped pads will have a 0.25 mm diameter. This footprint is recommended for MDI (Medium Density) PCB designs that are generally less expensive to build.

**Figure 10. Top View Standard Footprint (Recommended) for CCG6DF, CCG6SF 96-BGA**

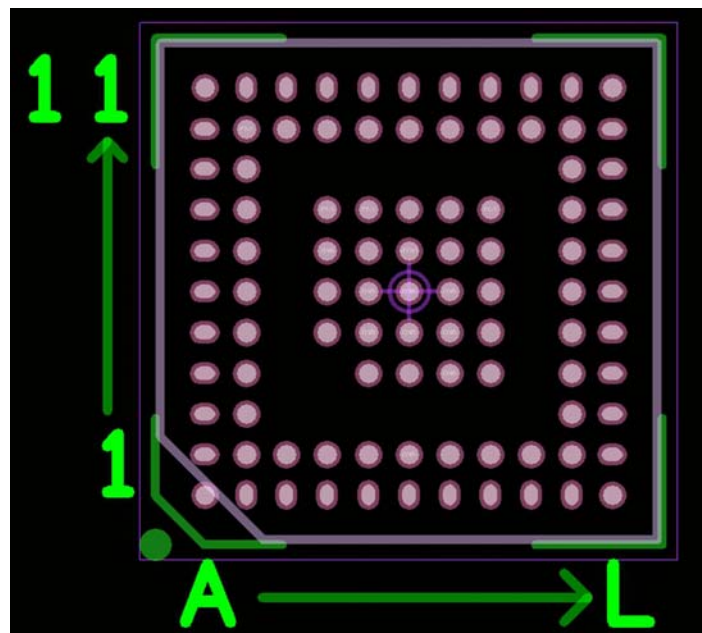

**Usage of Via Size of 8-mil drill/16-mil diameter and 10-mil drill/16-mil diameter**

In order to use larger via size of 8/16 (8-mil drill and 16-mil diameter) or 10/16 (10-mil drill and 16-mil diameter), one GPIO (BGA pad D8) is unusable and should be left unconnected. This would free up space underneath the package. This is a critical factor that helps to decide the minimum drill size for the vias. Two different pad sizes for the BGA balls are recommended for better yield in terms of assembly. Note that if GPIO pad D8 cannot be freed up, 6 mil hole / 12 mil diameter via sizes can be used to do PCB trace routing.

Via size of greater than 10-mil drill and 16-mil diameter is not feasible for inner BGA pads. Drill hole size of greater than 10-mils overlaps with the BGA pads and may result in “cold solder” during SMT reflow. Figure 11 shows the recommended 8/16 and 10/16 minimum via sizes (8-mil drill and 16-mil diameter).

**Figure 11. Recommended Pad Size and Via Size (8/16 and 10/16)**

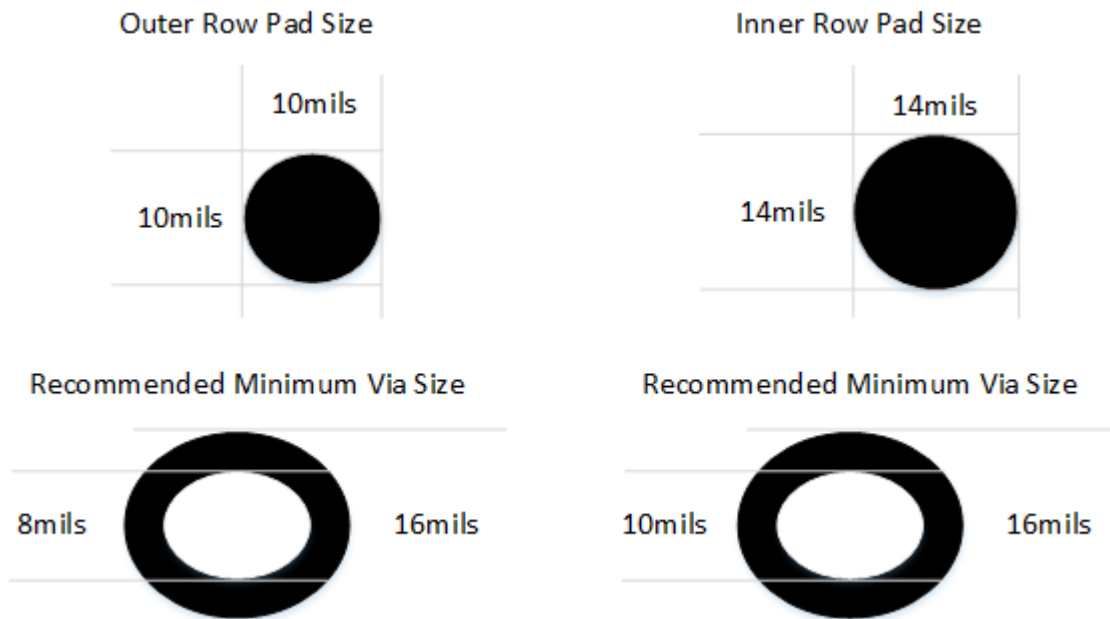

*Layer Stack-up*

A typical 8-layer stack up with 1 oz of copper is shown in [Figure 12](#).

**Figure 12. Eight Layer Stack-Up**

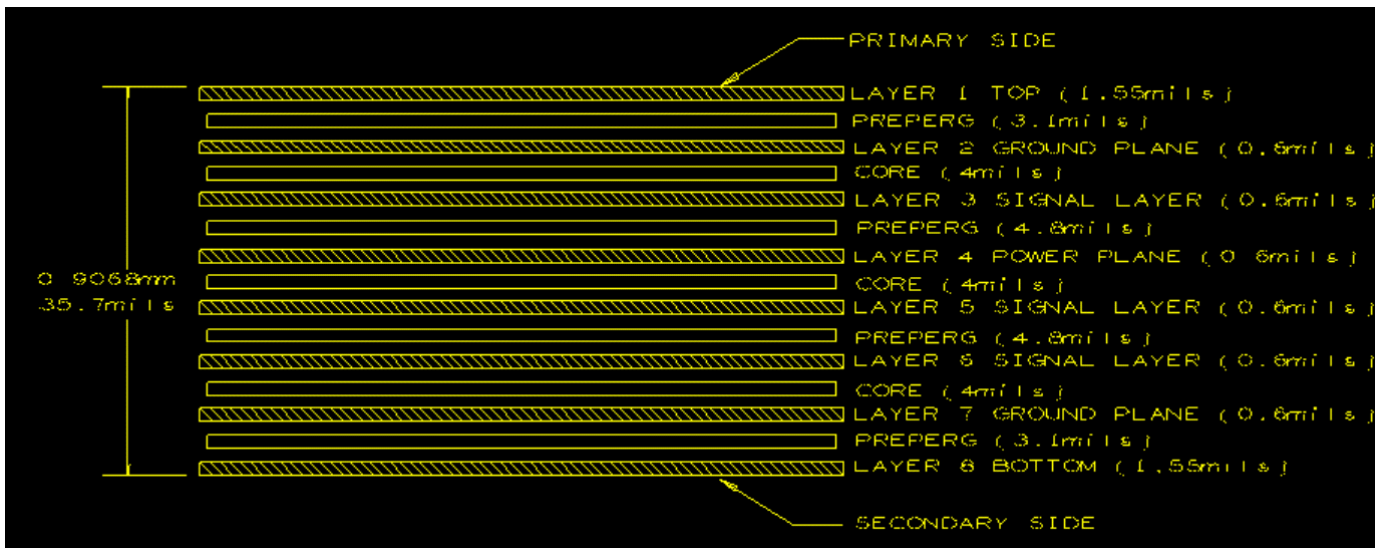

*Top Layer Fan Out*

Figure 13 shows a method of routing inner BGA balls and fan-out method for the routing for 8/16 or 10/16 via sizes.

**Figure 13. Top Layer Fan Out (8/16 or 10/16 via sizes)**

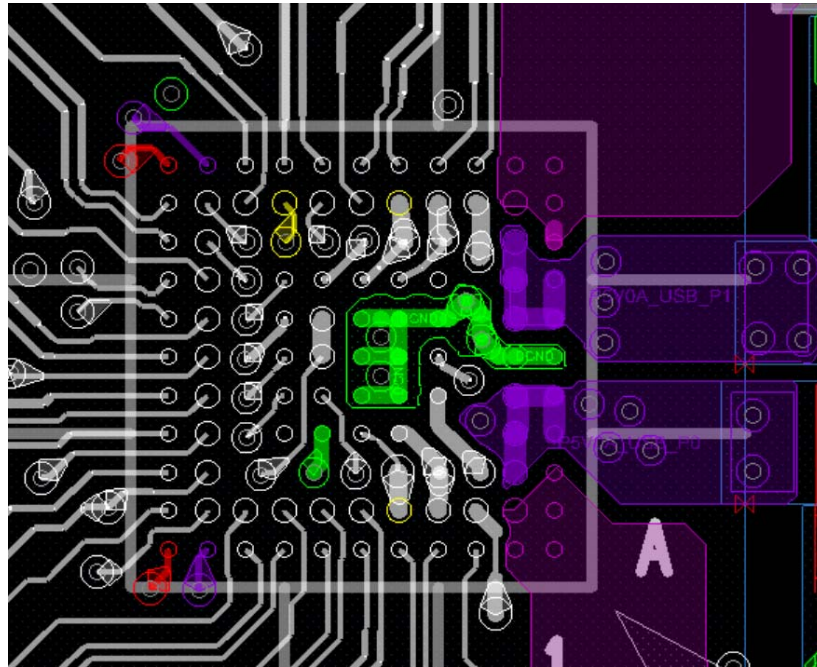

*Via Count for GND Pads*

Each via has a thermal resistance of 219 °C/W. Adding three such vias will help reducing thermal resistance to 73 °C/W and would help to distribute the heat better. As shown in Figure 14, it is recommended to short the 6 GND pads with a small split plane on the top layer and have a minimum of two vias to meet the thermal performance. Elevated temperature of more than 100 °C on BGA top may be observed if the via count is lesser than recommended. It is also recommended to have one via on GND pad (D7) with a trace width of 7mils.

**Figure 14. Via Count for GND Pads (8/16 or 10/16 via sizes)**

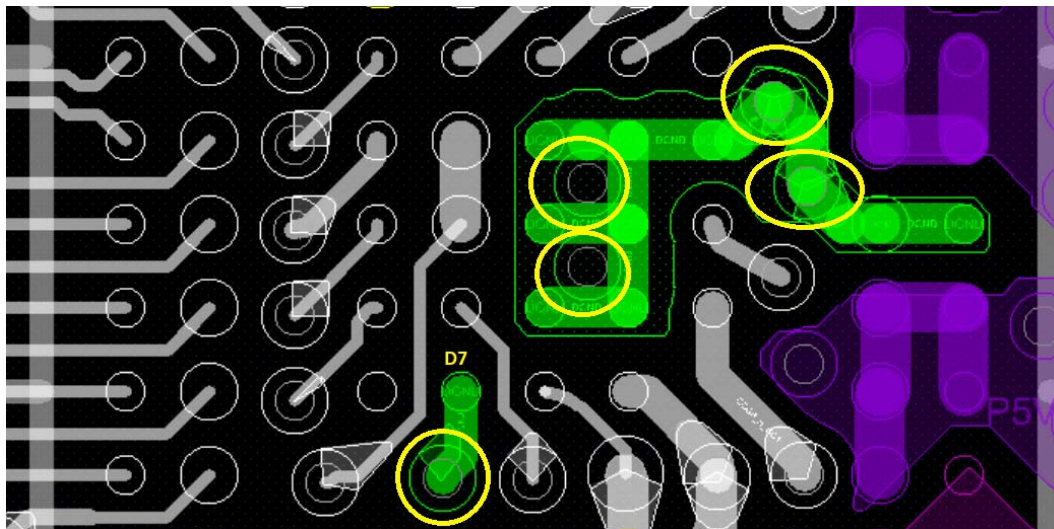

*Via Count for Provider Pads*

As shown in [Figure 15](#), it is recommended to create a copper pour around the 5 provider pads on the top and bottom layers with minimum of 7 vias. It is also recommended to split the power plane on other layer to meet the thermal performance. These vias play a crucial role in dissipating the heat better.

**Figure 15. Via Count for Provider Pads (8/16 or 10/16 via sizes)**

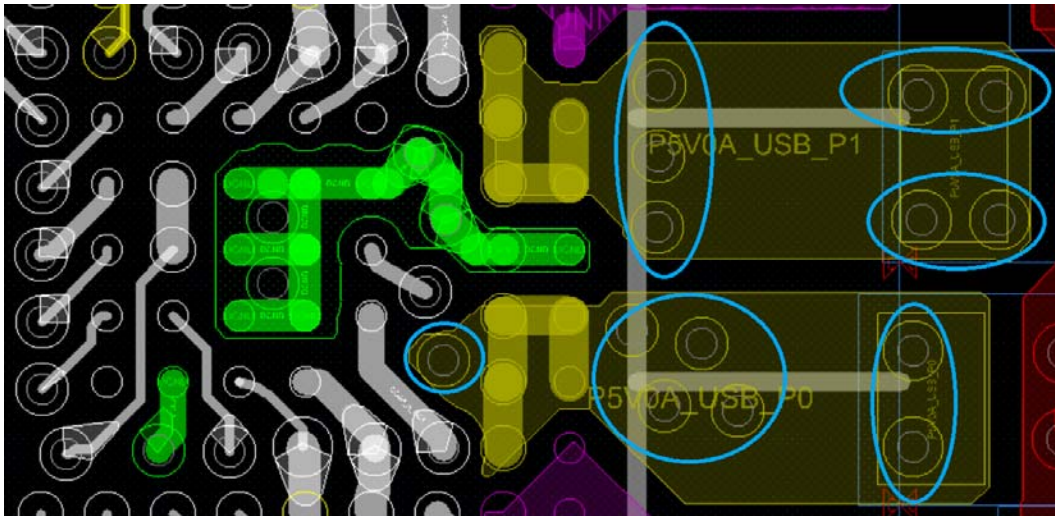

*High-Speed (DP\_SYS, DM\_SYS) USB Connections*

The traces of DP and DM lines with via size of 8-mil drill, 16-mil diameter and 10-mil drill, 16-mil diameter are shown in [Figure 16](#).

**Figure 16. DP/DM Traces (8/16 or 10/16 via sizes)**

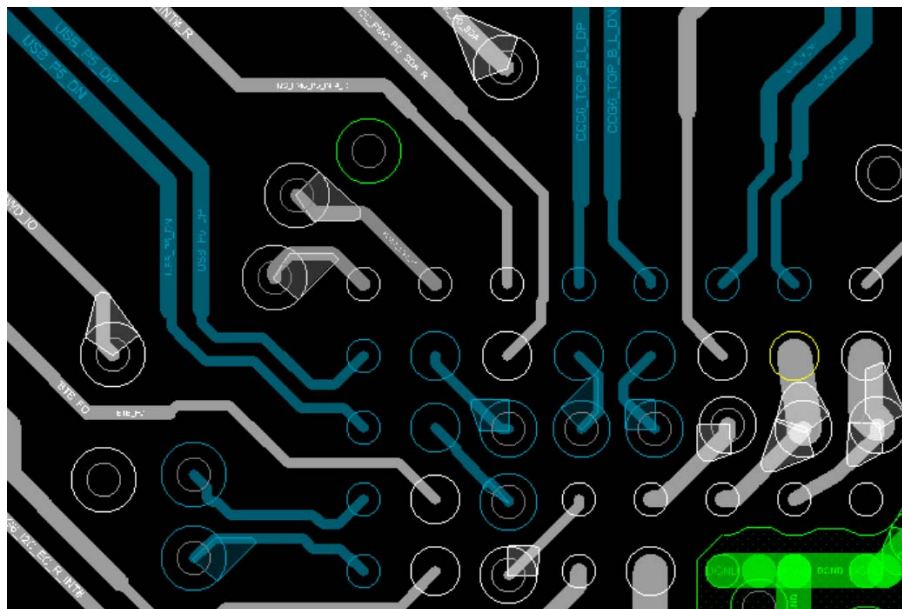



*CC Connections*

CC lines for CCG6DF/CCG6SF devices carry ~500-mA current. In the top layer, two CC pads are shorted using 0.2mm trace width and connected to other layers through one via. The capacitors are placed on bottom layer and are routed to the Type-C Connector. The CC1 and CC2 fan out for both ports is in the below [Figure 17](#) and [Figure 18](#).

**Figure 17. CC1 and CC2 Fan Out for Both Ports (Top Layer)**

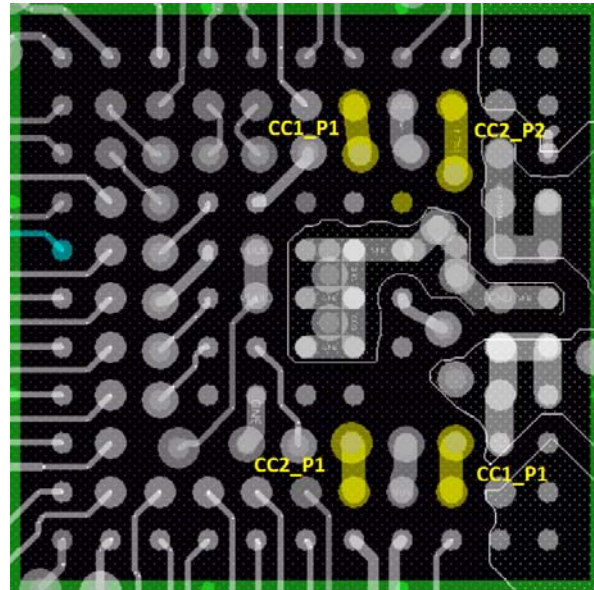

**Figure 18. CC1 and CC2 Fan Out for Both Ports (Bottom Layer)**

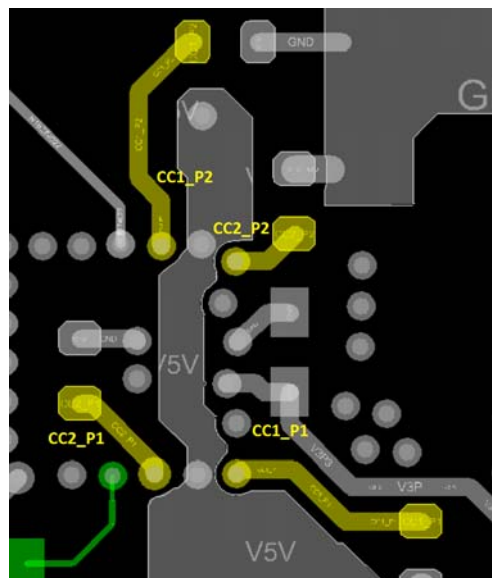

*Rsense and Capacitor Connections for Provider VBUS*

It is always advisable to keep the sense resistor (Rsense) close to CCG6DF/CCG6SF as it has internal VBUS provider switch. Connection from the regulator to Rsense should be done using big copper shape (pour) for carrying high currents.

The longer the trace length between components, the higher the voltage drop between components. The additional resistance reduces efficiency of the system. The resistance of trace can be calculated from below equation.

$$R_{trace} = \rho \times \frac{Tracelength}{Tracewidth \times Tracethickness}$$

Where the bulk resistance  $\rho$ , of copper is  $0.67 \mu\Omega/in$  or  $1.7 \mu\Omega/cm$  at  $25^\circ C$ .

The differential signal from Rsense should be length matched. The capacitor for Provider VBUS should be as close as possible to the Rsense and connected using copper shape. [Figure 19](#) and [Figure 20](#) show routing for Rsense.

**Figure 19. Rsense Resistor Placement (Top Layer)**

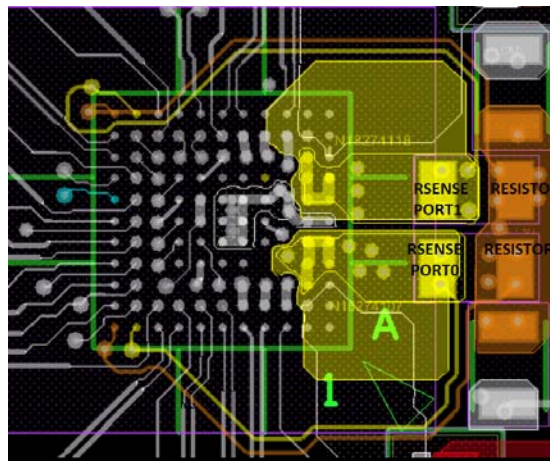

**Figure 20. Rsense Resistor Trace Routing with Kelvin Connection (Inner Layer)**

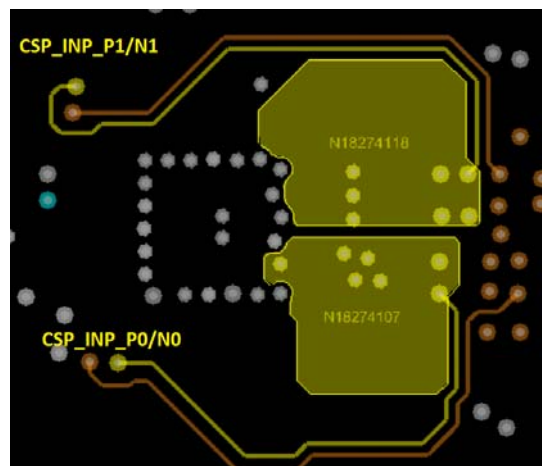

*Trace Width Details for Critical Signals*

Table 5 provides information on routing trace width for this layout example.

**Table 5. Route Trace Width**

Route	Route Width (mils) (1-oz Copper Thickness)	Remarks / Key Feature / Constraints
CC1, CC2	8	Current rating = 500 mA
GPIOs	5	-
DP/DM/Dsys	6 mils width/8mils spacing	90-Ω impedance signals
V <sub>DDIO</sub>	10	Current rating = 15 mA
V <sub>DDD</sub>		Current rating = 20 mA
V <sub>CCD</sub>		
V <sub>SYS</sub>		
V5V		

*V<sub>DDIO</sub>, V<sub>CCD</sub>, V<sub>SYS</sub>, and V<sub>DDD</sub> Connections*

Figure 21 and Figure 22 show how the V<sub>DDIO</sub>, V<sub>DDD</sub>, V<sub>SYS</sub>, and V<sub>CCD</sub> signals get routed amongst the top and bottom layers.

**Figure 21. Top Layer Connection for V<sub>DDIO</sub>, V<sub>DDD</sub>, V<sub>SYS</sub> and V<sub>CCD</sub>**

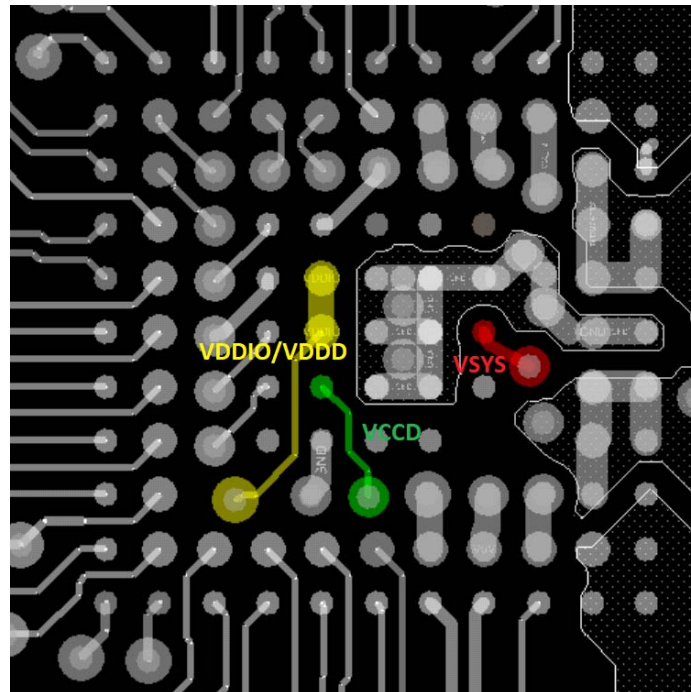
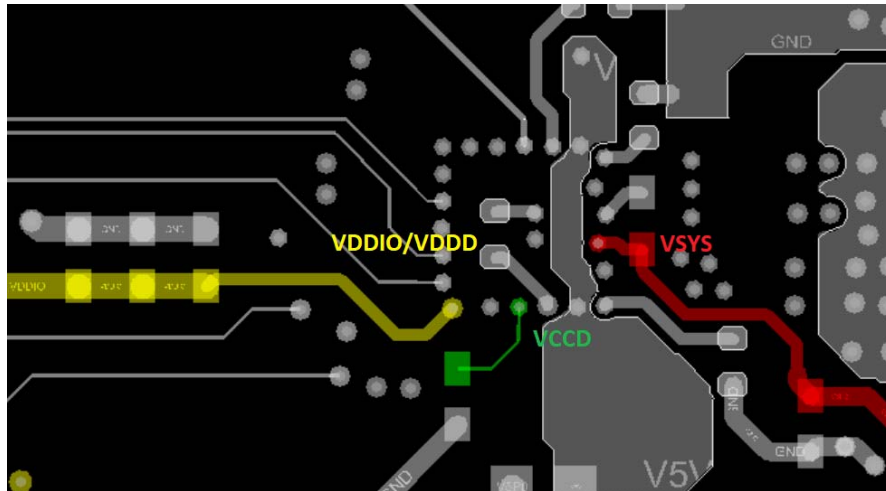

Figure 22. Bottom Layer Connection for  $V_{DDIO}$ ,  $V_{DDD}$ ,  $V_{SYS}$  and  $V_{CCD}$



Capacitor Connections for CC Lines and Bypass Capacitors for  $V_{DDIO}$ ,  $V_{DDD}$ ,  $V_{CCD}$ , and  $V_{SYS}$  Pins

Figure 23 shows how the relevant capacitors can be placed for via sizes of 8-mil drill, 16-mil diameter or 10-mil drill, 16-mil diameter.

Figure 23. Capacitor Connections (Top and Bottom Layer Placements for 8/16 or 10/16 via size)

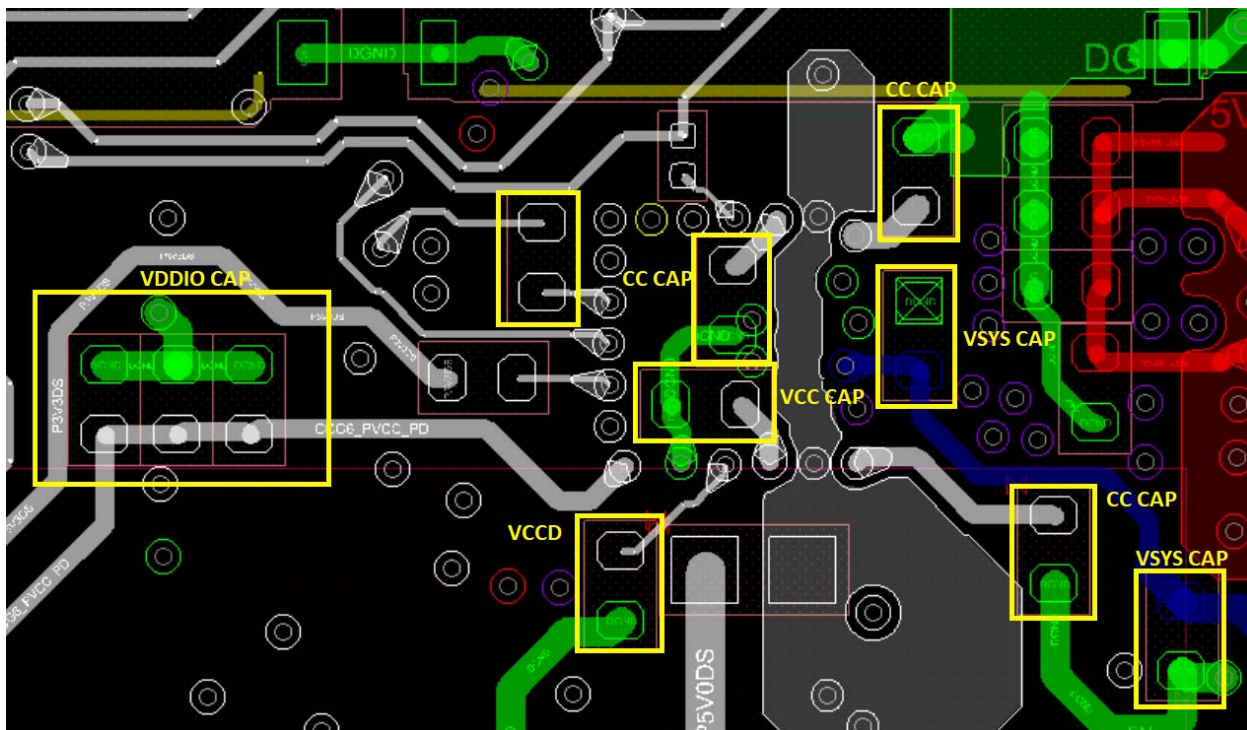

## Electrical Specifications

### Absolute Maximum Ratings

**Table 6. Absolute Maximum Ratings<sup>[4]</sup>**

Parameter	Description	Min	Typ	Max	Unit	Details/Conditions
V <sub>SYS_MAX</sub>	Supply relative to V <sub>SS</sub>	–	–	6	V	–
V <sub>5V_MAX</sub>	Max supply voltage relative to V <sub>SS</sub>	–	–	6		
V <sub>BUS_C_MAX</sub>	Max V <sub>BUS</sub> voltage relative to V <sub>SS</sub>	–	–	24		
V <sub>DDIO_MAX</sub>	Max supply voltage relative to V <sub>SS</sub>	–	–	V <sub>DDIO</sub>		
V <sub>GPIO_ABS</sub>	Inputs to GPIO, DP/DM mux (UART, SYS, DP/DM_top/bot pins), SBU mux (SBU1/2 pins)	–0.5	–	V <sub>DDIO</sub> + 0.5		
I <sub>GPIO_ABS</sub>	Maximum current per GPIO	–25	–	25	mA	–
I <sub>GPIO_INJECTION</sub>	GPIO injection current, Max for V <sub>IH</sub> > V <sub>DDIO</sub> , and Min for V <sub>IL</sub> < V <sub>SS</sub>	–0.5	–	0.5		Absolute max, current injected per pin
ESD_HBM	Electrostatic discharge human body model	2200	–	–	V	Applicable for all pins except SBU1_P0/1, SBU2_P0/1, CC1_0/1, CC2_0/1, VBUS_P_P0/1 & VBUS_C_P0/1 pins.
ESD_HBM_SBU	Electrostatic discharge human body model for SBU1, SBU2 pins	1100	–	–		Only applicable to SBU1_P0/1, SBU2_P0/1 pins
ESD_HBM_CC	Electrostatic discharge human body model for CC1 and CC2 pins for both ports	1100	–	–		Only applicable to CC1_P0/1, CC2_P0/1 pins
ESD_CDM	Electrostatic discharge charged device model	500	–	–		Charged Device Model ESD
ESD_HBM_VBUS	Electrostatic discharge human body model for VBUS_P_P0/1 & VBUS_C_P0/1 pins	500	–	–	V	Only applicable to VBUS_P_P0/1 & VBUS_C_P0/1 pins
LU	Pin current for latch-up	–100	–	100	mA	–
VCC_PIN_ABS	Max voltage on CC1 and CC2 pins	–	–	24	V	–
V <sub>SBU_PIN_ABS</sub>	Max voltage on SBU1 and SBU2 pins	–	–	24		–
V <sub>GPIO_OVT_ABS</sub>	OVT pins (16, 17) voltage	–0.5	–	6		–
T <sub>A</sub>	Internal system ambient temperature	–40	–	55	°C	Ambient temp inside system enclosure
T <sub>J</sub>	Junction temperature	–40	–	125		–

**Note**

4. Usage above the absolute maximum conditions listed in Table 6 may cause permanent damage to the device. Exposure to absolute maximum conditions for extended periods of time may affect device reliability. The maximum storage temperature is 150 °C in compliance with JEDEC Standard JESD22-A103, High Temperature Storage Life. When used below absolute maximum conditions but above normal operating conditions, the device may not operate to specification.

**Device-Level Specifications**

All specifications are valid for  $-40\text{ }^{\circ}\text{C} \leq T_A \leq 55\text{ }^{\circ}\text{C}$  and  $T_J \leq 125\text{ }^{\circ}\text{C}$ , except where noted. Specifications are valid for 3.0 V to 5.5 V except where noted.

*DC Specifications*

**Table 7. DC Specifications (Operating Conditions)**

Spec ID	Parameter	Description	Min	Typ	Max	Unit	Details/Conditions
SID.PWR#23	V <sub>SYS_UEFP</sub>	V <sub>SYS</sub> valid range	2.75	–	5.5	V	UEFP applications
SID.PWR#23_A	V <sub>SYS_UEFP_DRP</sub>	–	3	–	5.5		DFP/DRP applications
SID.PWR#22	VBUS_C	VBUS_C Port 0/1 valid range	4	–	21.5		–
SID.PWR#22A	VBUS_P	VBUS_P Port 0/1 valid range	4.9	–	5.5		This is not a power pin.
SID.PWR#1	V <sub>DDD</sub>	Regulated output voltage when V <sub>SYS</sub> powered	V <sub>SYS</sub> – 0.05	–	V <sub>SYS</sub>		–40 °C ≤ T <sub>A</sub> ≤ +55 °C
SID.PWR#1_A	V <sub>DDD</sub>	Regulated output voltage when V <sub>BUS</sub> powered	3	–	3.65		–40 °C ≤ T <sub>A</sub> ≤ +55 °C
SID.PWR#26	V <sub>5V</sub>	–	4.85	–	5.5		–
SID.PWR#13	V <sub>DDIO</sub>	Supply voltage for I/O	V <sub>DDD</sub>	–	V <sub>DDD</sub>		–40 °C ≤ T <sub>A</sub> ≤ +55 °C, All V <sub>DDD</sub>
SID.PWR#24	V <sub>CCD</sub>	Regulated output voltage (for Core Logic)	–	1.8	–		–
SID.PWR#15	C <sub>EFC</sub>	Regulator bypass capacitor for V <sub>CCD</sub>	–	100	–		nF
SID.PWR#16	C <sub>EXC</sub>	Power Supply decoupling capacitor for V <sub>DDD</sub>	–	1	–	μF	
<b>Active Mode, V<sub>SYS</sub> = 2.75 V to 5.5 V. Typical values measured at V<sub>SYS</sub> = 3.3 V</b>							
SID.PWR#4	I <sub>DD12</sub>	Supply current	–	10	–	mA	T <sub>A</sub> = 25 °C, CC I/O IN Transmit or Receive, no I/O sourcing current, CPU at 24 MHz, PD port active
<b>Deep Sleep Mode, V<sub>SYS</sub> = 2.75 V to 3.6 V</b>							
SID34	I <sub>DD29</sub>	V <sub>SYS</sub> = 2.75 to 3.6 V, I <sup>2</sup> C, wakeup and WDT on.	–	150	–	μA	V <sub>SYS</sub> = 3.3 V, T <sub>A</sub> = 25 °C
SID_DS1	I <sub>DD_DS1</sub>	V <sub>SYS</sub> = 3.3 V, CC wakeup on, Type-C not connected.	–	200	–	μA	Power source = V <sub>SYS</sub> , Type-C not attached, CC enabled for wakeup, R <sub>P</sub> and R <sub>D</sub> connected at 70-ms intervals by CPU. R <sub>D</sub> connection should be enabled by both PD ports.
SID_DS3	I <sub>DD_DS2</sub>	V <sub>SYS</sub> = 3.3 V, CC wakeup on, DP/DM, SBU ON with NGDO/CSA/UVOV On	–	500	–		One Port attached, Chip in Deep-sleep
<b>XRES Current</b>							
SID307	I <sub>DD_XR</sub>	Supply current while XRES asserted	–	130	–	μA	Power Source = V <sub>SYS</sub> = 3.3 V, Type-C Not Attached, T <sub>A</sub> = 25 °C

CPU

**Table 8. CPU Specifications (Guaranteed by Characterization)**

Spec ID	Parameter	Description	Min	Typ	Max	Unit	Details/Conditions
SID.CLK#4	F <sub>CPU</sub>	CPU input frequency	–	–	48	MHz	–40 °C ≤ T <sub>A</sub> ≤ +55 °C, All V <sub>DDD</sub>
SID.PWR#21	T <sub>DEEPSLEEP</sub>	Wakeup from Deep Sleep mode	–	35	–	μs	Guaranteed by characterization
SYS.XRES#5	T <sub>XRES</sub>	External reset pulse width	5	–	–		
SYS.FES#1	T <sub>PWR_RDY</sub>	Power-up to “Ready to accept I <sup>2</sup> C/CC command”	–	5	25	ms	

GPIO

**Table 9. GPIO DC Specifications**

Spec ID	Parameter	Description	Min	Typ	Max	Unit	Details/Conditions
SID.GIO#37	V <sub>IH_CMOS</sub>	Input voltage HIGH threshold	0.7 × V <sub>DDIO</sub>	–	–	V	CMOS input
SID.GIO#38	V <sub>IL_CMOS</sub>	Input voltage LOW threshold	–	–	0.3 × V <sub>DDIO</sub>		
SID.GIO#39	V <sub>IH_VDDIO2.7-</sub>	LVTTL input, V <sub>DDIO</sub> < 2.7 V	0.7 × V <sub>DDIO</sub>	–	–		–
SID.GIO#40	V <sub>IL_VDDIO2.7-</sub>	LVTTL input, V <sub>DDIO</sub> < 2.7 V	–	–	0.3 × V <sub>DDIO</sub>		–
SID.GIO#41	V <sub>IH_VDDIO2.7+</sub>	LVTTL input, V <sub>DDIO</sub> ≥ 2.7 V	2.0	–	–		–
SID.GIO#42	V <sub>IL_VDDIO2.7+</sub>	LVTTL input, V <sub>DDIO</sub> ≥ 2.7 V	–	–	0.8		–
SID.GIO#33	V <sub>OH_3V</sub>	Output voltage HIGH level	V <sub>DDIO</sub> – 0.6	–	–	V	I <sub>OH</sub> = –4 mA at 3-V V <sub>DDIO</sub>
SID.GIO#35C	V <sub>OL1_20mA</sub>	Output low voltage	–	–	0.4		I <sub>OL</sub> = 20 mA, V <sub>DDIO</sub> > 3.0 V, Applicable for overvoltage-tolerant pins only
SID.GIO#36	V <sub>OL_3V</sub>	Output voltage LOW level	–	–	0.6	V	I <sub>OL</sub> = 10 mA at 3-V V <sub>DDIO</sub>
SID.GIO#5	R <sub>pu</sub>	Pull-up resistor when enabled	3.5	5.6	8.5	kΩ	+25 °C T <sub>A</sub> , All V <sub>DDIO</sub>
SID.GIO#6	R <sub>pd</sub>	Pull-down resistor when enabled	3.5	5.6	8.5		
SID.GIO#16	I <sub>IL</sub>	Input leakage current (absolute value)	–	–	2	nA	+25 °C T <sub>A</sub> , 3-V V <sub>DDIO</sub>
SID.GIO#17	C <sub>PIN</sub>	Max pin capacitance	–	3	7	pF	–40 °C ≤ T <sub>A</sub> ≤ +55 °C, ALL V <sub>DDD</sub> , ALL I/Os
SID.GIO#43	V <sub>HYSTTL</sub>	Input hysteresis, LVTTL, V <sub>DDIO</sub> > 2.7 V	15	40	–	mV	V <sub>DDIO</sub> > 2.7 V. Guaranteed by characterization.
SID.GIO#44	V <sub>HYSCMOS</sub>	Input hysteresis CMOS	0.05 × V <sub>DDIO</sub>	–	–		V <sub>DDIO</sub> < 4.5 V
SID.GIO#44A	V <sub>HYSCMOS55</sub>	Input hysteresis CMOS	200	–	–		V <sub>DDIO</sub> > 4.5 V

**Table 10. GPIO AC Specifications (Guaranteed by Characterization)**

Spec ID	Parameter	Description	Min	Typ	Max	Unit	Details/Conditions
SID70	T <sub>RISEF</sub>	Rise time in Fast Strong mode	2	–	12	ns	3.3-V V <sub>DDIO</sub> , C <sub>load</sub> = 25 pF
SID71	T <sub>FALLF</sub>	Fall time in Fast Strong mode	2	–	12		
SID.GIO#46	T <sub>RISES</sub>	Rise time in Slow Strong mode	10	–	60		
SID.GIO#47	T <sub>FALLS</sub>	Fall time in Slow Strong mode	10	–	60		
SID.GIO#48	F <sub>GPIO_OUT1</sub>	GPIO F <sub>OUT</sub> ; 3.3 V ≤ V <sub>DDIO</sub> ≤ 5.5 V. Fast Strong mode.	–	–	16	MHz	90/10%, 25-pF load
SID.GIO#49	F <sub>GPIO_OUT2</sub>	GPIO F <sub>OUT</sub> ; 1.7 V ≤ V <sub>DDIO</sub> ≤ 3.3 V. Fast Strong mode.	–	–	16	MHz	90/10%, 25-pF load
SID.GIO#50	F <sub>GPIO_OUT3</sub>	GPIO F <sub>OUT</sub> ; 3.3 V ≤ V <sub>DDIO</sub> ≤ 5.5 V. Slow Strong mode.	–	–	7		
SID.GIO#51	F <sub>GPIO_OUT4</sub>	GPIO F <sub>OUT</sub> ; 1.7 V ≤ V <sub>DDIO</sub> ≤ 3.3 V. Slow Strong mode.	–	–	3.5		
SID.GIO#52	F <sub>GPIO_IN</sub>	GPIO input operating frequency; 1.7 V ≤ V <sub>DDIO</sub> ≤ 5.5 V.	–	–	16		90/10% V <sub>IO</sub>

**XRES**

**Table 11. XRES DC Specifications**

Spec ID	Parameter	Description	Min	Typ	Max	Unit	Details/Conditions
SID.XRES#1	V <sub>IH_XRES</sub>	Input voltage HIGH threshold on XRES pin	0.7 × V <sub>DDIO</sub>	–	–	V	CMOS input
SID.XRES#2	V <sub>IL_XRES</sub>	Input voltage LOW threshold on XRES pin	–	–	0.3 × V <sub>DDIO</sub>		
SID.XRES#3	C <sub>IN_XRES</sub>	Input capacitance on XRES pin	–	–	7	pF	–
SID.XRES#4	V <sub>HYSXRES</sub>	Input voltage hysteresis	–	0.05 × V <sub>DDIO</sub>	–	mV	Guaranteed by characterization



**Digital Peripherals**

The following specifications apply to the Timer/Counter/PWM peripherals in the Timer mode.

*Pulse Width Modulation (PWM) for GPIO Pins*

**Table 12. PWM AC Specifications** (Guaranteed by Characterization)

Spec ID	Parameter	Description	Min	Typ	Max	Unit	Details/Conditions
SID.TCPWM.3	TCPWM <sub>FREQ</sub>	Operating frequency	–	–	F <sub>c</sub>	MHz	F <sub>c</sub> max = 48 MHz
SID.TCPWM.4	T <sub>PWMENEXT</sub>	Input trigger pulse width	2/F <sub>c</sub>	–	–	ns	For all trigger events
SID.TCPWM.5	T <sub>PWMEXT</sub>	Output trigger pulse width	2/F <sub>c</sub>	–	–		Minimum possible width of Overflow, Underflow, and CC (Counter equals Compare value) outputs
SID.TCPWM.5A	T <sub>CRES</sub>	Resolution of counter	1/F <sub>c</sub>	–	–		Minimum time between successive counts
SID.TCPWM.5B	PWM <sub>RES</sub>	PWM resolution	1/F <sub>c</sub>	–	–		Minimum pulse width of PWM output
SID.TCPWM.5C	Q <sub>RES</sub>	Quadrature inputs resolution	1/F <sub>c</sub>	–	–		Minimum pulse width between quadrature-phase inputs

*I<sup>2</sup>C*

**Table 13. Fixed I<sup>2</sup>C AC Specifications**

(Guaranteed by Characterization)

Spec ID	Parameter	Description	Min	Typ	Max	Unit	Details/Conditions
SID153	F <sub>I2C1</sub>	Bit rate	–	–	1	Mbps	–

*UART*

**Table 14. Fixed UART AC Specifications**

(Guaranteed by Characterization)

Spec ID	Parameter	Description	Min	Typ	Max	Unit	Details/Conditions
SID162	F <sub>UART</sub>	Bit rate	–	–	1	Mbps	–

*SPI*

**Table 15. Fixed SPI AC Specifications**

(Guaranteed by Characterization)

Spec ID	Parameter	Description	Min	Typ	Max	Unit	Details/Conditions
SID166	F <sub>SPI</sub>	SPI operating frequency (Master; 6X oversampling)	–	–	8	MHz	–

**Table 16. Fixed SPI Master Mode AC Specifications**

(Guaranteed by Characterization)

Spec ID	Parameter	Description	Min	Typ	Max	Unit	Details/Conditions
SID167	T <sub>DMO</sub>	MOSI valid after SClk driving edge	–	–	15	ns	–
SID168	T <sub>DSI</sub>	MISO valid before SClk capturing edge	20	–	–		Full clock, late MISO sampling
SID169	T <sub>HMO</sub>	Previous MOSI data hold time	0	–	–		Referred to slave capturing edge

**Table 17. Fixed SPI Slave Mode AC Specifications**

(Guaranteed by Characterization)

Spec ID	Parameter	Description	Min	Typ	Max	Unit	Details/Conditions
SID170	T <sub>DMI</sub>	MOSI valid before Sclock capturing edge	40	–	–	ns	–
SID171	T <sub>D<sub>SO</sub></sub>	MISO valid after Sclock driving edge	–	–	48 + (3 × T <sub>CPU</sub> )		T <sub>CPU</sub> = 1/F <sub>CPU</sub>
SID171A	T <sub>D<sub>SO_EXT</sub></sub>	MISO valid after Sclock driving edge in Ext Clk mode	–	–	48		–
SID172	T <sub>H<sub>SO</sub></sub>	Previous MISO data hold time	0	–	–		–
SID172A	T <sub>SSEL<sub>SCK</sub></sub>	SSEL valid to first SCK Valid edge	100	–	–		–

*Memory*

**Table 18. Flash AC Specifications**

Spec ID	Parameter	Description	Min	Typ	Max	Unit	Details/Conditions
SID.MEM#4	T <sub>ROW_WRITE</sub>	Row (Block) write time (erase and program)	–	–	20	ms	–40 °C ≤ T <sub>A</sub> ≤ +55 °C, All V <sub>DD</sub>
SID.MEM#3	T <sub>ROW_ERASE</sub>	Row erase time	–	–	13		25 °C to 55 °C, All V <sub>DD</sub>
SID.MEM#8	T <sub>ROWPROGRAM</sub>	Row program time after erase	–	–	7		Guaranteed by design
SID178	T <sub>BULKERASE</sub>	Bulk erase time (64 KB)	–	–	35	s	–
SID180	T <sub>DEVPROG</sub>	Total device program time	–	–	25	s	–
SID.MEM#6	FLASH_ENPB	Flash write endurance	100k	–	–	cycles	–
SID182	F <sub>RET1</sub>	Flash retention, T <sub>A</sub> ≤ 55 °C, 100K P/E cycles	20	–	–	years	–
SID182A	F <sub>RET2</sub>	Flash retention, T <sub>A</sub> ≤ 85 °C, 10K P/E cycles	10	–	–		–

**System Resources**

*Power-on-Reset (POR) with Brown Out*

**Table 19. Imprecise Power-on Reset (IPOR)**

Spec ID	Parameter	Description	Min	Typ	Max	Unit	Details/Conditions
SID185	V <sub>RISEIPOR</sub>	Power-on reset (POR) rising trip voltage	0.80	–	1.50	V	–
SID186	V <sub>FALLIPOR</sub>	POR falling trip voltage	0.70	–	1.4		

**Table 20. Precise POR**

Spec ID	Parameter	Description	Min	Typ	Max	Unit	Details/Conditions
SID190	V <sub>FALLPPOR</sub>	Brown-out Detect (BOD) trip voltage in active/sleep modes	1.48	–	1.62	V	–
SID192	V <sub>FALLDPSLP</sub>	BOD trip voltage in Deep Sleep mode	1.1	–	1.5		

*SWD Interface*

**Table 21. SWD Interface Specifications**

Spec ID	Parameter	Description	Min	Typ	Max	Unit	Details/Conditions
SID.SWD#1	F_SWCLK1	$3.3\text{ V} \leq V_{DDIO} \leq 5.5\text{ V}$	–	–	14	MHz	SWDCLK ≤ 1/3 CPU clock frequency
SID.SWD#2	F_SWCLK2	$1.8\text{ V} \leq V_{DDIO} \leq 3.3\text{ V}$	–	–	7		
SID.SWD#3	T_SWDI_SETUP	T = 1/f SWDCLK	0.25 × T	–	–	ns	–
SID.SWD#4	T_SWDI_HOLD	T = 1/f SWDCLK	0.25 × T	–	–		
SID.SWD#5	T_SWDO_VALID	T = 1/f SWDCLK	–	–	0.50 × T		
SID.SWD#6	T_SWDO_HOLD	T = 1/f SWDCLK	1	–	–		

*Internal Main Oscillator*

**Table 22. IMO AC Specifications**

(Guaranteed by Design)

Spec ID	Parameter	Description	Min	Typ	Max	Unit	Details/Conditions
SID.CLK#13	F <sub>IMOTOL</sub>	Frequency variation at 48 MHz (trimmed)	–	–	±2	%	2.7 V ≤ V <sub>DDD</sub> < 5.5 V. –25 °C ≤ T <sub>A</sub> ≤ 55 °C
SID226	T <sub>STARTIMO</sub>	IMO start-up time	–	–	7	µs	–
SID.CLK#1	F <sub>IMO</sub>	IMO frequency	–	48	–	MHz	–40 °C ≤ T <sub>A</sub> ≤ +55 °C, All V <sub>DDD</sub>

*Internal Low-speed Oscillator*

**Table 23. ILO AC Specifications**

Spec ID	Parameter	Description	Min	Typ	Max	Unit	Details/Conditions
SID234	T <sub>STARTILO1</sub>	I <sub>LO</sub> start-up time	–	–	2	ms	Guaranteed by characterization
SID238	T <sub>ILODUTY</sub>	I <sub>LO</sub> duty cycle	40	50	60	%	
SID.CLK#5	F <sub>ILO</sub>	I <sub>LO</sub> frequency	20	40	80	kHz	–

PD

**Table 24. PD DC Specifications**

Spec ID	Parameter	Description	Min	Typ	Max	Unit	Details/Conditions
SID.DC.cc_shvt.1	vSwing	Transmitter Output High Voltage	1.05	–	1.2	V	–
SID.DC.cc_shvt.2	vSwing_low	Transmitter Output Low Voltage		–	0.075		–
SID.DC.cc_shvt.3	zDriver	Transmitter output impedance	33	–	75	Ω	–
SID.DC.cc_shvt.4	zBmcRx	Receiver Input Impedance	10	–		MΩ	Guaranteed by design
SID.DC.cc_shvt.5	Idac_std	Source current for USB standard advertisement	64	–	96	μA	–
SID.DC.cc_shvt.6	Idac_1p5a	Source current for 1.5A at 5 V advertisement	165.6	–	194.4		–
SID.DC.cc_shvt.7	Idac_3a	Source current for 3A at 5 V advertisement	303.6	–	356.4		–
SID.DC.cc_shvt.8	Rd	Pull down termination resistance when acting as UFP (upstream facing port)	4.59	–	5.61	kΩ	–
SID.DC.cc_shvt.9	Rd_db	Pull down termination resistance when acting as UFP, with dead battery	4.08	–	6.12		–
SID.DC.cc_shvt.10	zOPEN	CC impedance to ground when disabled	108	–			–
SID.DC.cc_shvt.11	DFP_default_0p2	CC voltages on DFP side-Standard USB	0.15	–	0.25	V	–
SID.DC.cc_shvt.12	DFP_1.5A_0p4	CC voltages on DFP side-1.5A	0.35	–	0.45		–
SID.DC.cc_shvt.13	DFP_3A_0p8	CC voltages on DFP side-3A	0.75	–	0.85		–
SID.DC.cc_shvt.14	DFP_3A_2p6	CC voltages on DFP side-3A	2.45	–	2.75		–
SID.DC.cc_shvt.15	UFP_default_0p66	CC voltages on UFP side-Standard USB	0.61	–	0.7		–
SID.DC.cc_shvt.16	UFP_1.5A_1p23	CC voltages on UFP side-1.5A	1.16	–	1.31		–
SID.DC.cc_shvt.17	Vattach_ds	Deep sleep attach threshold	0.3	–	0.6	%	–
SID.DC.cc_shvt.18	Rattach_ds	Deep sleep pull-up resistor	10	–	50	kΩ	–
SID.DC.cc_shvt.19	VTX_step	TX Drive voltage step size	80	–	120	mV	–
SID.DC.cc_shvt.30	FS_0p53	Voltage threshold for Fast Swap Detect	0.49	–	0.58	V	–

Analog-to-Digital Converter

**Table 25. ADC DC Specifications**

Spec ID	Parameter	Description	Min	Typ	Max	Unit	Details/Conditions
SID.ADC.1	Resolution	ADC resolution	–	8	–	Bits	–
SID.ADC.2	INL	Integral non-linearity	–1.5	–	1.5	LSB	–
SID.ADC.3	DNL	Differential non-linearity	–2.5	–	2.5		–
SID.ADC.4	Gain Error	Gain error	–1.5	–	1.5		–
SID.ADC.5	VREF_ADC1	Reference voltage of ADC	V <sub>DDmin</sub>	–	V <sub>DDmax</sub>	V	Reference voltage generated from V <sub>DD</sub>
SID.ADC.6	VREF_ADC2	Reference voltage of ADC	1.96	2.0	2.04		Reference voltage generated from deep sleep reference

*V<sub>sys</sub> Switch*

**Table 26. V<sub>sys</sub> Switch Specifications**

Spec ID	Parameter	Description	Min	Typ	Max	Unit	Details/Conditions
SID.DC.VDDDSW.1	Res_sw	Resistance from supply input to output supply V <sub>DDD</sub>	–	–	1.5	Ω	Measured with a load current of 5 mA to 10 mA on V <sub>DDD</sub> .

*CSA*

**Table 27. CSA DC Specifications**

Spec ID	Parameter	Description	Min	Typ	Max	Unit	Details/Conditions
DC.csa_scp.42	SCP_6A	Short circuit current detect @ 6A	–	±10	–	%	–
DC.csa_scp.43	SCP_10A	Short circuit current detect @10A	–	±10	–		–
OP.csa_scp.11	Rsense	External sense register	4.95	5	5.05	mΩ	
DC.csa_scp.44	locp_1A	OCP Trip threshold for 1A	–	130 ±20%	–	%	1A PD contracts OCP set at 130% of contract value or user programmable
DC.csa_scp.45	locp_5A	OCP Trip threshold for 2A, 3A, 4A and 5A contracts	–	130 ±10%	–		2A, 3A, 4A, and 5A PD contracts OCP set at 130% of contract value OR user programmable
DC.rcp_scp.7a	I_csainn_lk	CSP pin input leakage when RCP and CSA blocks are OFF	–	–	10	μA	For provider V <sub>BUS_P_P0/1</sub> = 5 V
DC.rcp_scp.6a	I_csainp_lk	CSN pin input leakage when RCP and CSA blocks are OFF	–	–	80		
DC.sys.1	I_CSP_RCP_ON_CSA_OFF	CSP pin current when RCP block is ON and SCP is OFF	–	–	20		
DC.sys.2	I_CSN_RCP_ON_CSA_OFF	CSN pin current when RCP block is ON and SCP is OFF	–	–	100		
DC.sys.3	I_CSP_CSA_ON	CSP pin current when RCP block is OFF and SCP is ON	–	–	30		
DC.sys.4	I_CSN_CSA_ON	CSN pin current when RCP block is OFF and SCP is ON	–	–	100		
DC.sys.5	I_CSP_RCP_ON_CSA_ON	CSP pin current when RCP block is ON and SCP is ON	–	–	50		For provider V <sub>BUS</sub> = 5 V. Guaranteed by design.
DC.sys.6	I_CSP_RCP_ON_CAS_ON	CSN pin current when RCP block is ON and SCP is ON	–	–	120		

*V<sub>bus</sub> UV/OV*

**Table 28. V<sub>bus</sub> UV/OV Specifications**

Spec ID	Parameter	Description	Min	Typ	Max	Unit	Details/Conditions
SID.UVOV.1	V <sub>THUVOV1</sub>	Voltage threshold accuracy in active mode using bandgap reference	–	±3	–	%	–
SID.UVOV.2	V <sub>THUVOV2</sub>	Voltage threshold accuracy in deep sleep mode using deep sleep reference	–	±5	–		–
SID.COMP_ACC	COMP_ACC	Comparator input offset at 4sigma	–15	–	15	mV	–

Provider Side RCP

**Table 29. Provider Side RCP DC Specifications**

Spec ID	Parameter	Description	Min	Typ	Max	Unit	Details/Conditions
DC.RCP.44	Vcsa_rcp	Voltage across external Rsense between CSP/CSN for which RCP condition detected (CSN higher than CSP by Vcsa_rcp)	-	2	6	mV	-
DC.RCP.45	Vcomp_rcp	Voltage across V <sub>BUS</sub> and CSN pins for which RCP condition is detected	20	-	130		-
DC.RCP.46	Vbus_max_det	Voltage on CSN pad during provider FET ON (source) for which RCP condition is triggered (this threshold is user programmable)	-	5.375	-	V	-

**Table 30. Provider Side RCP, SCP AC Specifications**

Spec ID	Parameter	Description	Min	Typ	Max	Unit	Details/Conditions
AC.RCP_SYS.1	Toff_rcp	Provider NFET switching off after reverse current detect through provider FET (for 20-V hot plug-in)	-	1	-	µs	VBUS = 5 V/3A, Provider path ON, 47-µF ceramic cap on VBUS_P pin
AC.RCP_SYS.2	Ton	Time taken to detect RCP out-of-fault	-	55	80	µs	VBUS falls below CSN and start NGDO enable

**Table 31. V<sub>BUS</sub> Provider Switch Specifications**

Spec ID	Parameter	Description	Min	Typ	Max	Unit	Details/Conditions
DC.ngdo_fet_sys.1	RDS <sub>ON</sub>	FET RDS <sub>ON</sub> (96-BGA)	-	40	55	mΩ	3A Load current, Short-duration pulse, -40 °C to 55 °C TA
DC.ngdo_fet_sys.1a	RDS <sub>ON</sub>	FET RDS <sub>ON</sub> (48-QFN)	-	45	55		
DC.NGDO_FET_SYS.2	Isw	Continuous current	-	-	3.0	A	If one port is sourcing 3A, the other port can source only up to 1.5A. Measurement done in pulse mode.
AC.NGDO_FET_SYS.1	Ton	V <sub>BUS</sub> Low to High (10% to 90%)	-	5	-	ms	0.8 to 4.5-V transition, system-level (with 10Ω load on VBUS_C)
AC.NGDO_FET_SYS.2	Toff_fault	VBUS High to Low (90% to 10%) - Under fault condition of SCP/RCP	-	1	-	µs	
AC.NGDO_FET_SYS.3	Toff	VBUS High to Low (90% to 10%) - Under normal condition	-	7	-		
AC.NGDO_FET_SYS.4	OTSth_OFF	Overtemperature shutdown threshold OFF, Junction temperature	-	125	-	°C	-
AC.NGDO_FET_SYS.5	OTSth_OFF	Overtemperature shutdown threshold ON, Junction temperature	-	90	-	°C	-

SBU Switch

**Table 32. SBU Switch DC Specifications**

Spec ID	Parameter	Description	Min	Typ	Max	Unit	Details/Conditions
DC.ccg6df.20sbu.1	Ron1	On resistance of AUXP/N to SBU1/2 switch @3.3-V input	-	4	7	Ω	-
DC.ccg6df.20sbu.2	Ron2	On resistance of AUXP/N to SBU1/2 switch @1-V input	-	3	5		-
DC.ccg6df.20sbu.4	Ileak1	Pin leakage current for SBU1, SBU2	-4.5	-	4.5	μA	-
DC.ccg6df.20sbu.5	Ileak2	Pin leakage current for SBU1_SYS, SBU2_SYS	-1	-	1	μA	-
DC.ccg6df.20sbu.16	OVP_threshold	Overvoltage protection detection threshold above V <sub>DDIO</sub>	200	-	1200	mV	-
DC.ccg6df.20sbu.19	aux_ron_flat_fs	Switch On flat resistance of SBU1/2_SYS to SBU1/2 switch (from 0 to 3.3 V)	-	-	2.5	Ω	-
DC.ccg6df.20sbu.20	aux_ron_flat_hs	Switch On flat resistance of SBU1/2_SYS to SBU1/2 switch (from 0 to 1 V)	-	-	0.5		-

**Table 33. SBU Switch AC Specifications**

Spec ID	Parameter	Description	Min	Typ	Max	Unit	Details/Conditions
AC.ccg6df.20sbu.1	Con	Switch On capacitance	-	-	120	pF	-
AC.ccg6df.20sbu.2	Coff	Switch Off capacitance-Connector side	-	-	80		Guaranteed by design
AC.ccg6df.20sbu.3	Off_isolation	Switch isolation at F = 1 MHz	-50	-	-	dB	
AC.ccg6df.20sbu.4	TON	SBU switch turn-on time	-	-	200	μs	-
AC.ccg6df.20sbu.5	TOFF	SBU switch turn-off time	-	-	400		-
AC.ccg6df.20sbu.3_aux	Off_isolation_AC_aux	Switch isolation at F = 1 MHz, from SBU_5V to SBU pins	-50	-	-	dB	Guaranteed by design
AC.ccg6df.20sbu.6_aux	Off_isolation_tan_dB_aux	Coupling on sbu1, 2 terminated to 50 Ω, switch-OFF, 1-MHz rail-to-rail toggling on SBU1_5V, SBU2_5V	-30	-	-		
AC.ccg6df.20sbu.7_aux	X_talk_AC_aux	Cross talk of Switch at F = 1 MHz SBU1/2 to SBU2/1 when is data transferred from SBU1/2_5V	-50	-	-		Guaranteed by design
AC.ccg6df.20sbu.8_aux	X_talk_tran_dB_aux	Coupling on SBU2 (1) When Data is transferred from SBU1(2)_5V to SBU1 (2). Rail-to-rail data on SBU1(2), static signal on SBU2(1)	-30	-	-		

DP/DM Switch

**Table 34. DP/DM Switch DC Specifications**

Spec ID	Parameter	Description	Min	Typ	Max	Unit	Details/ Conditions
DC.ccg6df.dpdm.1	RON_HS	DP/DM On resistance (0 to 0.5 V) - HS mode	-	-	8	Ω	-
DC.ccg6df.dpdm.2	RON_FS	DP/DM On resistance (0 to 3.3 V) - FS mode	-	-	12		-
DC.ccg6df.dpdm.5	Con_FS	Switch On capacitance at 6 MHz - FS mode	-	-	50	pF	Guaranteed by design
DC.ccg6df.dpdm.6	Con_HS	Switch on capacitance at 240 MHz - HS mode	-	-	10		
DC.ccg6df.dpdm.9	ileak_pin	pin leakage at DP/DM connector side and host side	-	-	1	μA	-
DC.ccg6df.dpdm.10	RON_UART	DP/DM On resistance for UART lines (0 to 3.3 V)	-	-	17	Ω	-
DC.ccg6df.dpdm.11	RON_FLAT_HS	DP/DM On Flat resistance in HS mode (0 to 0.4 V)	-	-	0.5		-
DC.ccg6df.dpdm.12	RON_FLAT_FS	DP/DM On flat resistance in FS mode (0 to 3.3 V)	-	-	4		-
DC.ccg6df.dpdm.13	RON_FLAT_UART	DP/DM UART On flat resistance (0 to 3.3 V)	-	-	4		-

**Table 35. DP/DM Switch AC Specifications**

Spec ID	Parameter	Description	Min	Typ	Max	Unit	Details/ Conditions
AC.ccg6df.dpdm.1	BW_3dB_HS	3-db bandwidth	700	-	-	MHz	-
AC.ccg6df.dpdm.2	BW_3dB_FS	3-db bandwidth	100	-	-		-
AC.ccg6df.dpdm.5	T <sub>ON</sub>	DP/DM Switch turn-on time	-	-	200	μs	-
AC.ccg6df.dpdm.6	T <sub>OFF</sub>	DP/DM Switch turn-off time	-	-	0.4		-
AC.ccg6df.dpdm.7	T <sub>ON_VPUMP</sub>	DP/DM charge pump startup time	-	-	200		-
AC.ccg6df.dpdm.8	Off_isolation_HS	Switch-off isolation for HS	-20	-	-	dB	Guaranteed by design
AC.ccg6df.dpdm.9	Off_isolation_FS	Switch-off isolation for FS	-50	-	-		
AC.ccg6df.dpdm.10	X_talk	Cross talk of Switch From FS to HS at F = 12 MHz	-50	-	-		
AC.ccg6df.dpdm.11	uart_coupling	Peak-to-peak coupling of UART signal to DP lines. (UART signal 0 to 3.3 V)	-	-	20		



VCONN Switch

**Table 36. VCONN Switch DC Specifications**

Spec ID	Parameter	Description	Min	Typ	Max	Unit	Details/Conditions
DC.ccg6df.20VCONN.1	R <sub>on</sub>	Switch ON resistance at V5V = 5 V with 215-mA load current	–	0.7	1.3	Ω	–
DC.ccg6df.20VCONN.9	I <sub>ocp</sub>	Overcurrent detection range for CC1/CC2	550	–	–	mA	–
DC.ccg6df.20VCONN.10	OVP_threshold	CC1, CC2 overvoltage protection detection threshold above V <sub>DD</sub> or V5V, whichever is higher	200	–	1200	mV	–
DC.ccg6df.20VCONN.11	OVP_hysteresis	Overvoltage detection hysteresis	50	–	200		Guaranteed by design
DC.ccg6df.20VCONN.12	OCP_hysteresis	Overcurrent detection hysteresis	20	–	60	mA	–
DC.ccg6.20VCONN.14	OVP_threshold_on	Overvoltage detection threshold above V5V of CC1/2, with CC1 or CC2 switch enabled. Same threshold triggers reverse current protection circuit.	200	–	700	mV	–

**Table 37. VCONN Switch AC Specifications**

Spec ID	Parameter	Description	Min	Typ	Max	Unit	Details/Conditions
AC.ccg6df.20VCONN.1	T <sub>ON</sub>	VCONN switch turn-on time	–	–	200	μs	–
AC.ccg6df.20VCONN.2	T <sub>OFF</sub>	VCONN switch turn-off time	–	–	3		Guaranteed by design

V<sub>BUS</sub>

**Table 38. V<sub>BUS</sub> Discharge Specifications**

Spec ID	Parameter	Description	Min	Typ	Max	Unit	Details/Conditions
SID.VBUS.DISC.1	R <sub>on1</sub>	20-V NMOS ON resistance (with dischg_ds<0> = 1; dischg_ds<4:1> = 0)	1500	–	3000	Ω	–
SID.VBUS.DISC.2	R <sub>on2</sub>	20-V NMOS ON resistance (with dischg_ds<1:0> = 1; dischg_ds<4:2> = 0)	750	–	1500		–
SID.VBUS.DISC.3	R <sub>on3</sub>	20-V NMOS ON resistance (with dischg_ds<2:0> = 1; dischg_ds<4:3> = 0)	500	–	1000		–
SID.VBUS.DISC.4	R <sub>on4</sub>	20-V NMOS ON resistance (with dischg_ds<3:0> = 1; dischg_ds<4> = 0)	375	–	750		–
SID.VBUS.DISC.5	R <sub>on5</sub>	20-V NMOS ON resistance (with dischg_ds<4:0> = 1)	300	–	600		–

## Ordering Information

Table 39 lists the EZ-PD CCG6DF, EZ-PD CCG6SF part numbers and features.

**Table 39. EZ-PD CCG6DF Ordering Information**

Product	Part Number	Application	Integrated VBUS Switch	Type-C Ports	Dead Battery Termination	Termination Resistor	Role	Package
CCG6SF	CYPD6127-96BZXI	Notebooks	Yes	1	Yes	Rp <sup>[5]</sup> , Rd <sup>[6]</sup>	DRP	96-ball BGA
CCG6SF	CYPD6127-48LQXI			1				48-pin LQXI
CCG6DF	CYPD6227-96BZXI			2				96-ball BGA

## Ordering Code Definitions

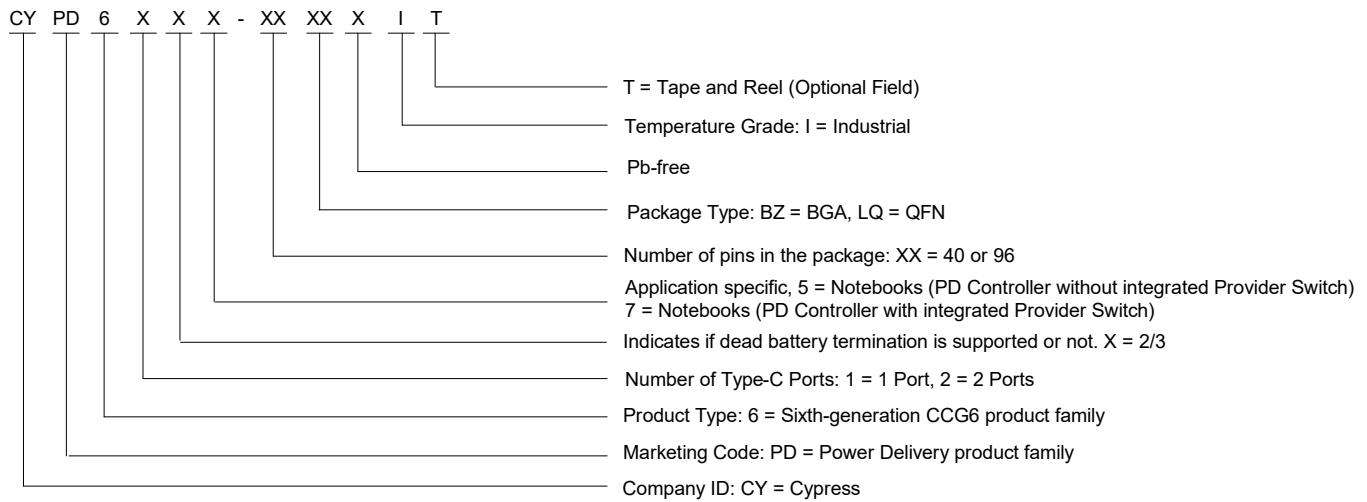

**Notes**

- 5. Termination resistor denoting a Source.
- 6. Termination resistor denoting an accessory or Sink.

**Packaging**

**Table 40. Package Characteristics**

Parameter	Description	Conditions	Min	Typ	Max	Unit
T <sub>A</sub>	Operating ambient temperature	Industrial	-40	25	55	°C
T <sub>J</sub>	Operating junction temperature				125	
T <sub>JA</sub>	Package θ <sub>JA</sub> (96-ball BGA)	-	-	-	56.9	°C/W
T <sub>JC</sub>	Package θ <sub>JC</sub> (96-ball BGA)				36.9	
T <sub>JA</sub>	Package θ <sub>JA</sub> (48-pin QFN)	-	-	-	40.2	°C/W
T <sub>JC</sub>	Package θ <sub>JC</sub> (48-pin QFN)				40.1	

**Table 41. Solder Reflow Peak Temperature**

Package	Maximum Peak Temperature	Maximum Time within 5 °C of Peak Temperature
96-ball BGA	260 °C	30 seconds
48-pin QFN		

**Table 42. Package Moisture Sensitivity Level (MSL), IPC/JEDEC J-STD-2**

Package	MSL
96-ball BGA	MSL 3
48-pin QFN	

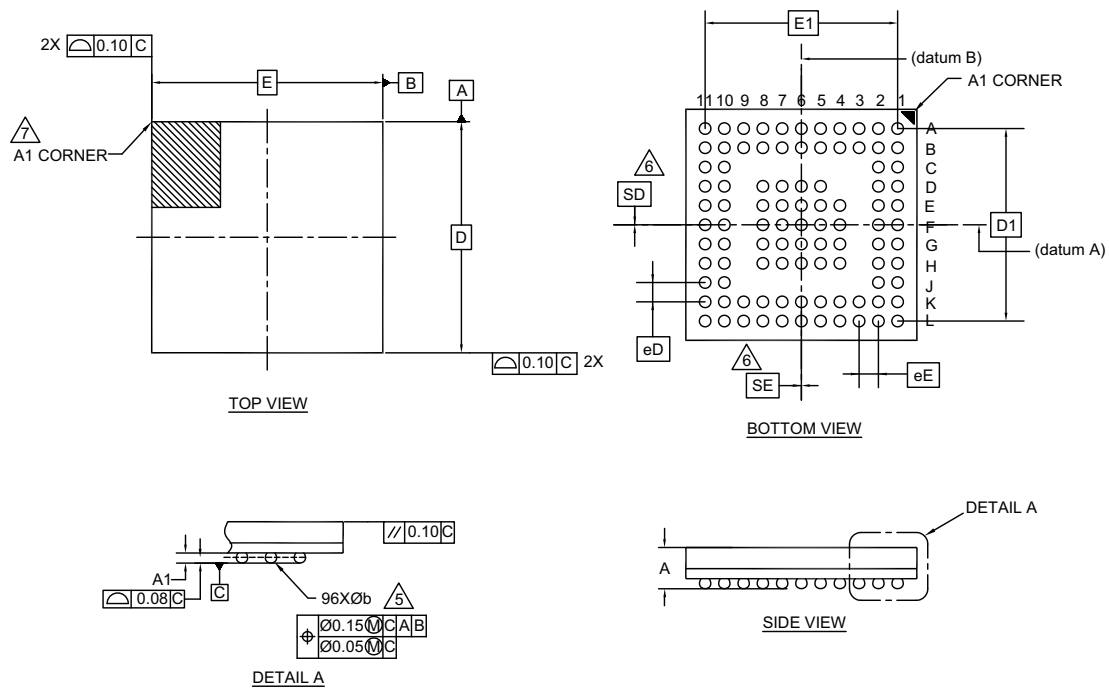
**Figure 24. 96-ball BGA (6 × 6 × 0.5 mm), 6.0 × 6.0 x 1.0 mm Package Outline**

**NOTES:**

1. ALL DIMENSIONS ARE IN MILLIMETERS.
2. SOLDER BALL POSITION DESIGNATION PER JEP95, SECTION 3, SPP-020.
3. "e" REPRESENTS THE SOLDER BALL GRID PITCH.
4. SYMBOL "MD" IS THE BALL MATRIX SIZE IN THE "D" DIRECTION. SYMBOL "ME" IS THE BALL MATRIX SIZE IN THE "E" DIRECTION. N IS THE NUMBER OF POPULATED SOLDER BALL POSITIONS FOR MATRIX SIZE MD X ME.
5. DIMENSION "b" IS MEASURED AT THE MAXIMUM BALL DIAMETER IN A PLANE PARALLEL TO DATUM C.
6. "SD" AND "SE" ARE MEASURED WITH RESPECT TO DATUMS A AND B AND DEFINE THE POSITION OF THE CENTER SOLDER BALL IN THE OUTER ROW WHEN THERE IS AN ODD NUMBER OF SOLDER BALLS IN THE OUTER ROW "SD" OR "SE" = 0. WHEN THERE IS AN EVEN NUMBER OF SOLDER BALLS IN THE OUTER ROW "SD" = eD/2 AND "SE" = eE/2.
7. A1 CORNER TO BE IDENTIFIED BY CHAMFER, LASER OR INK MARK METALIZED MARK, INDENTATION OR OTHER MEANS.
8. "+" INDICATES THE THEORETICAL CENTER OF DEPOPULATED SOLDER BALLS.
9. JEDEC SPECIFICATION NO. REF. : MO-225.

SYMBOL	DIMENSIONS		
	MIN.	NOM.	MAX.
A	-	-	1.00
A1	0.16	-	-
D	6.00 BSC		
E	6.00 BSC		
D1	5.00 BSC		
E1	5.00 BSC		
MD	11		
ME	11		
N	96		
∅ b	0.25	0.30	0.35
eD	0.50 BSC		
eE	0.50 BSC		
SD	0.00		
SE	0.00		

002-10631 \*B

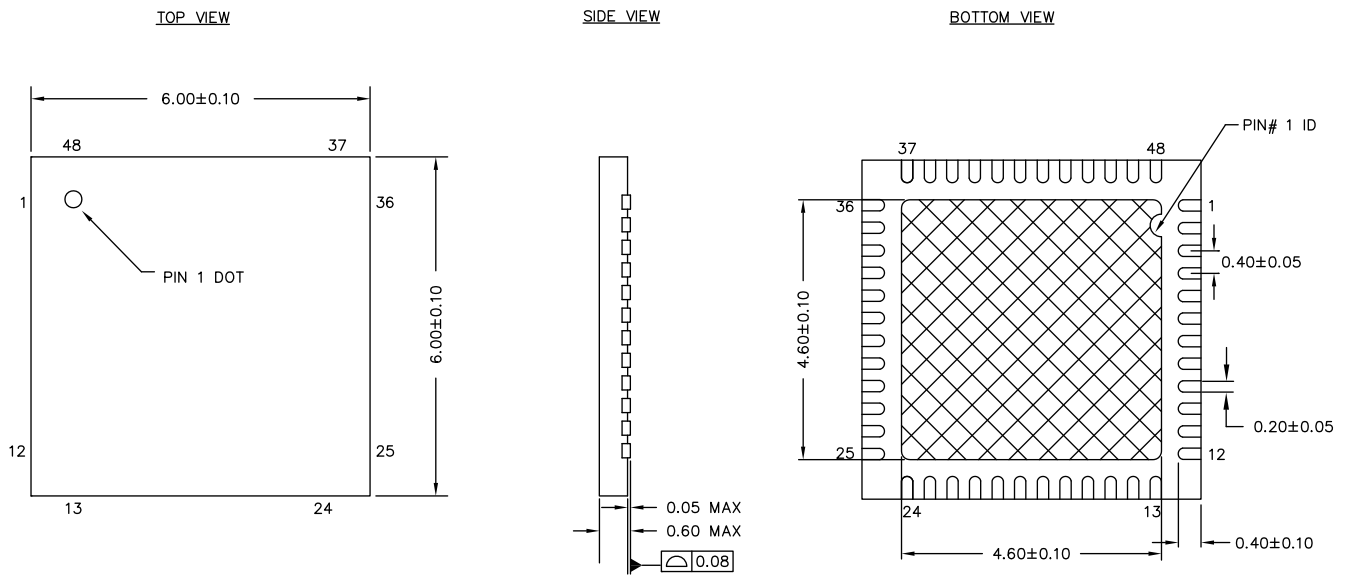
**Figure 25. 48L-QFN 6 mm x 6 mm x 0.6 mm Package Outline**



**NOTES:**

1. HATCH AREA IS SOLDERABLE EXPOSED PAD
2. REFERENCE JEDEC # MO-248
3. PACKAGE WEIGHT:  $68 \pm 7$  mg
4. ALL DIMENSIONS ARE IN MILLIMETERS

001-57280 \*E

**Acronyms**

**Table 43. Acronyms Used in this Document**

Acronym	Description
ADC	analog-to-digital converter
API	application programming interface
Arm®	advanced RISC machine, a CPU architecture
CC	configuration channel
CSN	current sense negative
BCC	battery charger controller
BOD	Brown out Detect
CC	configuration channel
CPU	central processing unit
CRC	cyclic redundancy check, an error-checking protocol
CS	current sense
CSA	current sense amplifier
CSN	current sense negative
CSP	current sense positive
DFP	downstream facing port
DM	data minus
DP	data plus signal
DP	DisplayPort, digital display interface developed by Video Electronics Standards Association
DIO	digital input/output, GPIO with only digital capabilities, no analog. See GPIO.
DRP	dual role power
EC	embedded controller
EEPROM	electrically erasable programmable read-only memory
EMCA	a USB cable that includes an IC that reports cable characteristics (e.g., current rating) to the Type-C ports
EMI	electromagnetic interference
ESD	electrostatic discharge
FPB	flash patch and breakpoint
FRS	fast role swap
FS	full-speed
GPIO	general-purpose input/output
HDI	high density interconnect
HSCSA	high-side current sense amplifier
IC	integrated circuit
IDE	integrated development environment
I <sup>2</sup> C, or IIC	Inter-Integrated Circuit, a communications protocol

**Table 43. Acronyms Used in this Document (continued)**

Acronym	Description
ILO	internal low-speed oscillator, see also IMO
IMO	internal main oscillator, see also ILO
I/O	input/output, see also GPIO
IPOR	imprecise POR
IRQ	interrupt request
ISR	interrupt service request
LVD	low-voltage detect
LVTTL	low-voltage transistor-transistor logic
MCU	microcontroller unit
MDI	medium density
NC	no connect
NGDO	N-FET gate driver output
NMI	nonmaskable interrupt
NVIC	nested vectored interrupt controller
opamp	operational amplifier
OCP	overcurrent protection
OVP	overvoltage protection
PCB	printed circuit board
PD	power delivery
PGA	programmable gain amplifier
PHY	physical layer
POR	power-on reset
PRES	precise power-on reset
PSoC®	Programmable System-on-Chip™
PWM	pulse-width modulator
RAM	random-access memory
RCP	reverse current protection
RISC	reduced-instruction-set computing
RMS	root-mean-square
RTC	real-time clock
RX	receive
SAR	successive approximation register
SCB	serial communication block
SCL	I <sup>2</sup> C serial clock
SDA	I <sup>2</sup> C serial data
S/H	sample and hold
SPI	Serial Peripheral Interface, a communications protocol
SRAM	static random access memory
SWD	serial wire debug, a test protocol

**Table 43. Acronyms Used in this Document** *(continued)*

Acronym	Description
TBT	Thunderbolt, hardware interface standard for peripherals developed by Intel
TCPWM	timer/counter pulse-width modulation
TRNG	true random number generator
TX	transmit
Type-C	a new standard with a slimmer USB connector and a reversible cable, capable of sourcing up to 100 W of power
UART	Universal Asynchronous Transmitter Receiver, a communications protocol
UFP	upstream facing port
USB	Universal Serial Bus
USBIO	USB input/output, CCG6D/CCG6DF pins used to connect to a USB port
USBTCAS	USB Type-C Authentication Specification
UVOV	under-voltage/over-voltage
WDT	watchdog timer
XRES	external reset I/O pin

**Document Conventions**

**Units of Measure**

**Table 44. Units of Measure**

Symbol	Unit of Measure
°C	degrees Celsius
Hz	hertz
KB	1024 bytes
kHz	kilohertz
kΩ	kilo ohm
Mbps	megabits per second
MHz	megahertz
MΩ	mega-ohm
Msps	megasamples per second
μA	microampere
μF	microfarad
μs	microsecond
μV	microvolt
μW	microwatt
mA	milliampere
mΩ	milliohm
ms	millisecond
mV	millivolt
nA	nanoampere
ns	nanosecond
Ω	ohm
pF	picofarad
ppm	parts per million
ps	picosecond
s	second
sps	samples per second
V	volt

## References and Links to Applications Collateral

### Knowledge Base Articles

- [Key Differences Among EZ-PD™ CCG1, CCG2, CCG3 and CCG5 - KBA210740](#)
- [Programming EZ-PD™ CCG2, EZ-PD™ CCG3 and EZ-PD™ CCG5 Using PSoC® Programmer and MiniProg3 - KBA96477](#)
- [CCGX Frequently Asked Questions \(FAQs\) - KBA97244](#)
- [Cypress EZ-PD™ CCGx Hardware - KBA204102](#)
- [Difference between USB Type-C and USB-PD - KBA204033](#)
- [CCGX Programming Methods - KBA97271](#)
- [Getting started with Cypress USB Type-C Products - KBA04071](#)
- [Type-C to DisplayPort Cable Electrical Requirements](#)
- [Dead Battery Charging Implementation in USB Type-C Solutions - KBA97273](#)
- [Termination Resistors Required for the USB Type-C Connector – KBA97180](#)
- [VBUS Bypass Capacitor Recommendation for Type-C Cable and Type-C to Legacy Cable/Adapter Assemblies – KBA97270](#)
- [Need for Regulator and Auxiliary Switch in Type-C to DisplayPort \(DP\) Cable Solution - KBA97274](#)
- [Need for a USB Billboard Device in Type-C Solutions – KBA97146](#)
- [Cypress USB Type-C Controller Supported Solutions – KBA97179](#)
- [Termination Resistors for Type-C to Legacy Ports – KBA97272](#)
- [Handling Instructions for CY4502 CCG2 Development Kit – KBA97916](#)
- [Thunderbolt™ Cable Application Using CCG3 Devices - KBA210976](#)
- [Power Adapter Application Using CCG3 Devices - KBA210975](#)
- [Methods to Upgrade Firmware on CCG3 Devices - KBA210974](#)
- [Device Flash Memory Size and Advantages - KBA210973](#)
- [Applications of EZ-PD™ CCG5 - KBA210739](#)

### Application Notes

- [AN95615 - Designing USB 3.1 Type-C Cables Using EZ-PD™ CCG2](#)
- [AN95599 - Hardware Design Guidelines for EZ-PD™ CCG2](#)
- [AN210403 - Hardware Design Guidelines for Dual Role Port Applications Using EZ-PD™ USB Type-C Controllers](#)
- [AN210771 - Getting Started with EZ-PD™ CCG4](#)

### Reference Designs

- [EZ-PD™ CCG2 Electronically Marked Cable Assembly \(EMCA\) Paddle Card Reference Design](#)
- [EZ-PD™ CCG2 USB Type-C to DisplayPort Cable Solution](#)
- [EZ-PD™ CCG2 USB Type-C to HDMI Adapter Solution](#)
- [EZ-USB GX3 USB Type-C to Gigabit Ethernet Dongle](#)
- [EZ-PD™ CCG2 USB Type-C Monitor/Dock Solution](#)
- [CCG2 20W Power Adapter Reference Design](#)
- [CCG2 18W Power Adapter Reference Design](#)
- [EZ-USB GX3 USB Type-A to Gigabit Ethernet Reference Design Kit](#)

### Kits

- [CY4502 EZ-PD™ CCG2 Development Kit](#)
- [CY4531 EZ-PD CCG3 Evaluation Kit](#)
- [CY4541 EZ-PD™ CCG4 Evaluation Kit](#)

### Datasheets

- [CYPD1120 Datasheet: USB Power Delivery Alternate Mode Controller on Type-C](#)
- [CCG2: USB Type-C Port Controller Datasheet](#)
- [CCG3: USB Type-C Controller Datasheet](#)
- [CCG5C: USB Type-C Controller Datasheet](#)



**Document History Page**

Document Title: EZ-PD CCG6DF, CCG6SF, USB Type-C Port Controller Document Number: 002-27161			
Revision	ECN	Submission Date	Description of Change
**	6580063	05/27/2019	Initial release
*A	6649813	08/09/2019	Modified Document Title for EZ-PD CCG6DF, CCG6SF, USB Type-C Controller. Updated <a href="#">EZ-PD CCG6DF, CCG6SF, USB Type-C Port Controller, Features, Logic Block Diagram, CCG6DF/CCG6SF Functional Diagram</a> and <a href="#">Application Diagrams</a> sections. Updated <a href="#">Table 2</a> , <a href="#">Table 39</a> , <a href="#">Table 40</a> , <a href="#">Table 41</a> , <a href="#">Table 42</a> . Added <a href="#">Table 3</a> . Updated <a href="#">Figure 4</a> , added <a href="#">Figure 5</a> , removed <a href="#">Figure 2</a> and <a href="#">Figure 3</a> from previous version.
*B	6673392	09/13/2019	Changed status from "Advance" to "Preliminary". Updated <a href="#">Logic Block Diagram, Features, CCG6DF/CCG6SF Functional Diagram</a> , and <a href="#">References and Links to Applications Collateral</a> . Added <a href="#">Functional Overview, Power, Application Diagrams</a> , and <a href="#">CCG6SF 48-pin QFN Single Port Thunderbolt Notebook Application Diagram</a> . Updated <a href="#">Table 2</a> , <a href="#">Table 3</a> , <a href="#">Table 39</a> , and <a href="#">Table 42</a> . Updated <a href="#">Figure 4</a> and <a href="#">Figure 5</a> . Added Electrical Specifications in <a href="#">Table 6</a> through <a href="#">Table 38</a> .
*C	6682221	09/26/2019	Updated <a href="#">Pinouts</a> (added new <a href="#">Figure 6</a> , new <a href="#">Table 4</a> ). Updated <a href="#">Ordering Information</a> , and <a href="#">Packaging</a> (added <a href="#">Figure 25</a> ). Updated <a href="#">Table 31</a> : Updated typical and max values for DC.ngdo.fet_sys.1 spec. Added new spec DC.ngdo.fet_sys.1a for QFN package.
*D	6732422	11/18/2019	Updated <a href="#">General Description</a> and <a href="#">Features</a> . Updated <a href="#">Figure 6</a> , <a href="#">Figure 7</a> , and <a href="#">Figure 8</a> . Updated <a href="#">Table 4</a> , <a href="#">Table 40</a> , <a href="#">Table 41</a> , and <a href="#">Table 42</a> . Added <a href="#">Figure 3</a> and <a href="#">Figure 9</a> . Updated <a href="#">Figure 24</a> .
*E	6769410	01/14/2020	Updated <a href="#">Logic Block Diagram</a> . Updated <a href="#">Figure 1</a> , <a href="#">Figure 4</a> , <a href="#">Figure 5</a> , <a href="#">Figure 7</a> , <a href="#">Figure 8</a> . Updated <a href="#">Table 2</a> , <a href="#">Table 3</a> , <a href="#">Table 7</a> (SID.PWR#1_A and SID_DS3 parameters), <a href="#">Table 29</a> (added DC.RCP.46 parameter) and <a href="#">Table 31</a> (RDS <sub>ON</sub> parameter for 96-BGA). Removed Usage of Via Size of 6-mil drill and 12-mil diameter section. Added <a href="#">Usage of Via Size of 8-mil drill/16-mil diameter and 10-mil drill/16-mil diameter</a> section. Updated Copyright information.

## Sales, Solutions, and Legal Information

### Worldwide Sales and Design Support

Cypress maintains a worldwide network of offices, solution centers, manufacturer's representatives, and distributors. To find the office closest to you, visit us at [Cypress Locations](#).

#### Products

Arm® Cortex® Microcontrollers	<a href="http://cypress.com/arm">cypress.com/arm</a>
Automotive	<a href="http://cypress.com/automotive">cypress.com/automotive</a>
Clocks & Buffers	<a href="http://cypress.com/clocks">cypress.com/clocks</a>
Interface	<a href="http://cypress.com/interface">cypress.com/interface</a>
Internet of Things	<a href="http://cypress.com/iot">cypress.com/iot</a>
Memory	<a href="http://cypress.com/memory">cypress.com/memory</a>
Microcontrollers	<a href="http://cypress.com/mcu">cypress.com/mcu</a>
PSoC	<a href="http://cypress.com/psoc">cypress.com/psoc</a>
Power Management ICs	<a href="http://cypress.com/pmic">cypress.com/pmic</a>
Touch Sensing	<a href="http://cypress.com/touch">cypress.com/touch</a>
USB Controllers	<a href="http://cypress.com/usb">cypress.com/usb</a>
Wireless Connectivity	<a href="http://cypress.com/wireless">cypress.com/wireless</a>

#### PSoC® Solutions

[PSoC 1](#) | [PSoC 3](#) | [PSoC 4](#) | [PSoC 5LP](#) | [PSoC 6 MCU](#)

#### Cypress Developer Community

[Community](#) | [Projects](#) | [Video](#) | [Blogs](#) | [Training](#) | [Components](#)

#### Technical Support

[cypress.com/support](http://cypress.com/support)

Notice regarding compliance with Universal Serial Bus specification. Cypress offers firmware and hardware solutions that are certified to comply with the Universal Serial Bus specification, USB Type-C™ Cable and Connector Specification, and other specifications of USB Implementers Forum, Inc (USB-IF). You may use Cypress or third party software tools, including sample code, to modify the firmware for Cypress USB products. Modification of such firmware could cause the firmware/hardware combination to no longer comply with the relevant USB-IF specification. You are solely responsible ensuring the compliance of any modifications you make, and you must follow the compliance requirements of USB-IF before using any USB-IF trademarks or logos in connection with any modifications you make. In addition, if Cypress modifies firmware based on your specifications, then you are responsible for ensuring compliance with any desired standard or specifications as if you had made the modification. CYPRESS IS NOT RESPONSIBLE IN THE EVENT THAT YOU MODIFY OR HAVE MODIFIED A CERTIFIED CYPRESS PRODUCT AND SUCH MODIFIED PRODUCT NO LONGER COMPLIES WITH THE RELEVANT USB-IF SPECIFICATIONS.

© Cypress Semiconductor Corporation, 2019-2020. This document is the property of Cypress Semiconductor Corporation and its subsidiaries ("Cypress"). This document, including any software or firmware included or referenced in this document ("Software"), is owned by Cypress under the intellectual property laws and treaties of the United States and other countries worldwide. Cypress reserves all rights under such laws and treaties and does not, except as specifically stated in this paragraph, grant any license under its patents, copyrights, trademarks, or other intellectual property rights. If the Software is not accompanied by a license agreement and you do not otherwise have a written agreement with Cypress governing the use of the Software, then Cypress hereby grants you a personal, non-exclusive, nontransferable license (without the right to sublicense) (1) under its copyright rights in the Software (a) for Software provided in source code form, to modify and reproduce the Software solely for use with Cypress hardware products, only internally within your organization, and (b) to distribute the Software in binary code form externally to end users (either directly or indirectly through resellers and distributors), solely for use on Cypress hardware product units, and (2) under those claims of Cypress's patents that are infringed by the Software (as provided by Cypress, unmodified) to make, use, distribute, and import the Software solely for use with Cypress hardware products. Any other use, reproduction, modification, translation, or compilation of the Software is prohibited.

TO THE EXTENT PERMITTED BY APPLICABLE LAW, CYPRESS MAKES NO WARRANTY OF ANY KIND, EXPRESS OR IMPLIED, WITH REGARD TO THIS DOCUMENT OR ANY SOFTWARE OR ACCOMPANYING HARDWARE, INCLUDING, BUT NOT LIMITED TO, THE IMPLIED WARRANTIES OF MERCHANTABILITY AND FITNESS FOR A PARTICULAR PURPOSE. No computing device can be absolutely secure. Therefore, despite security measures implemented in Cypress hardware or software products, Cypress shall have no liability arising out of any security breach, such as unauthorized access to or use of a Cypress product. CYPRESS DOES NOT REPRESENT, WARRANT, OR GUARANTEE THAT CYPRESS PRODUCTS, OR SYSTEMS CREATED USING CYPRESS PRODUCTS, WILL BE FREE FROM CORRUPTION, ATTACK, VIRUSES, INTERFERENCE, HACKING, DATA LOSS OR THEFT, OR OTHER SECURITY INTRUSION (collectively, "Security Breach"). Cypress disclaims any liability relating to any Security Breach, and you shall and hereby do release Cypress from any claim, damage, or other liability arising from any Security Breach. In addition, the products described in these materials may contain design defects or errors known as errata which may cause the product to deviate from published specifications. To the extent permitted by applicable law, Cypress reserves the right to make changes to this document without further notice. Cypress does not assume any liability arising out of the application or use of any product or circuit described in this document. Any information provided in this document, including any sample design information or programming code, is provided only for reference purposes. It is the responsibility of the user of this document to properly design, program, and test the functionality and safety of any application made of this information and any resulting product. "High-Risk Device" means any device or system whose failure could cause personal injury, death, or property damage. Examples of High-Risk Devices are weapons, nuclear installations, surgical implants, and other medical devices. "Critical Component" means any component of a High-Risk Device whose failure to perform can be reasonably expected to cause, directly or indirectly, the failure of the High-Risk Device, or to affect its safety or effectiveness. Cypress is not liable, in whole or in part, and you shall and hereby do release Cypress from any claim, damage, or other liability arising from any use of a Cypress product as a Critical Component in a High-Risk Device. You shall indemnify and hold Cypress, its directors, officers, employees, agents, affiliates, distributors, and assigns harmless from and against all claims, costs, damages, and expenses, arising out of any claim, including claims for product liability, personal injury or death, or property damage arising from any use of a Cypress product as a Critical Component in a High-Risk Device. Cypress products are not intended or authorized for use as a Critical Component in any High-Risk Device except to the limited extent that (i) Cypress's published data sheet for the product explicitly states Cypress has qualified the product for use in a specific High-Risk Device, or (ii) Cypress has given you advance written authorization to use the product as a Critical Component in the specific High-Risk Device and you have signed a separate indemnification agreement.

Cypress, the Cypress logo, Spansion, the Spansion logo, and combinations thereof, WICED, PSoC, CapSense, EZ-USB, F-RAM, and Traveo are trademarks or registered trademarks of Cypress in the United States and other countries. For a more complete list of Cypress trademarks, visit [cypress.com](http://cypress.com). Other names and brands may be claimed as property of their respective owners.